

TECHNICAL STANDARDS FOR DESIGN AND CONSTRUCTION

VILLAGE OF PINCKNEY
220 S. HOWELL STREET
PINCKNEY, MICHIGAN 48169

DATE ADOPTED: JANUARY 11, 2021



SECTION 00 01 10
TABLE OF CONTENTS

PRELIMINARY MATTERS

PREFACE

- 00 01 00 - Cover Page
- 00 01 10 - Table of Contents
- 00 50 00 - General
- 00 71 00 - Definitions

REQUIREMENTS

DESIGN STANDARDS

- 01 20 01 - Easement Requirements
- 01 20 02 - Maintenance Agreement Requirements
- 01 20 03 - Sanitary Sewer System Design Requirements
- 01 20 04 - Water System Design Requirements
- 01 20 05 - Storm Water System Design Requirements
- 01 20 06 - Site Grading Design Requirements
- 01 20 07 - Roadway, Parking, Driveway, and Sidewalk Design Requirements

ADMINISTRATIVE REQUIREMENTS

- 01 30 00 - Administrative Requirements
- 01 31 00 - Sample Performance and Maintenance and Guarantee Bond - **Obtain from Zoning Administrator**
- 01 32 00 - Sample Change Proposal
- 01 40 00 - Quality Requirements
- 01 50 00 - Temporary Facilities and Controls
- 01 51 00 - Temporary Utilities
- 01 60 00 - Product Requirements
- 01 70 00 - Execution and Closeout Requirements
- 01 78 00 - Closeout Submittals

CONSTRUCTION STANDARDS

EARTHWORK

- 31 22 00 - Stripping and Grading

31 23 00 - Dewatering

31 23 16.13 - Trenching

EXTERIOR IMPROVEMENTS

32 31 13 - Galvanized Chain Link Fence and Gates

32 92 19 - Restoration

UTILITIES

33 05 13 - Manholes and Structures

33 06 00 - Trace Wire and Locator Tape

33 07 00 - Directional Drilling

33 08 00 - Sewer Bypass Flow Control

33 09 00 - Sewer Cleaning and Televising

33 09 01 - Installation and Acceptance Testing of Pipe and Accessories

33 09 01.01 - Watermain Pressure Test

33 13 00 - Disinfecting of Water Utility Distribution

33 14 16 - Water Piping

33 31 13 - Sanitary Sewer Piping

33 31 23 - Sanitary Force Main Piping

33 32 13 - Packaged Wastewater Pumping Stations

33 42 11 - Storm Sewer Piping

TRANSPORTATION

34 01 00 - Street and other Hard Surface Improvements

34 10 00 - Resolution 5 of 2017 Regarding Driveway Replacement

STANDARD DETAILS

GENERAL DETAILS

48 80 00 - Utility Trenches

48 80 01 - Castings and Grates

48 80 03 - Water Softener Dry Well

WATERMAIN DETAILS

48 80 10 - Watermain Lowering

48 80 11 - Watermain Separation

- 48 80 12 - Gate Valves
- 48 80 13 - Gate Valve Manholes
- 48 80 14 - Watermain Livetap Manholes
- 48 80 15 - Residential Water Meters
- 48 80 16 - Water Services
- 48 80 17 - Hydrants
- 48 80 18 - Water System Trace Wire Plan

SANITARY SEWER DETAILS

- 48 80 20 - Standard Sanitary Manholes
- 48 80 21 - Shallow Sanitary Manholes
- 48 80 22 - Sanitary Risers
- 48 80 23 - Deep Cut Sanitary Risers
- 48 80 24 - Sanitary Drop Manhole
- 48 80 25 - Sanitary Sewer Cleanout
- 48 80 26 - Sanitary Sewer System Trace Wire Plan

STORM SEWER DETAILS

- 48 80 30 - Storm Manholes
- 48 80 31 - Storm Catch Basins
- 48 80 32 - Curb Underdrain
- 48 80 33 - Parking Underdrain
- 48 80 34 - Concrete Catch Basin Collar
- 48 80 35 - Driveway Culverts

END OF SECTION

SECTION 00 50 00

GENERAL

PART 1 GENERAL

1.01 STANDARDS

- A. The following represents standards for the design of sanitary sewers, water mains, storm sewers, driveways, sidewalks, retention/detention basins, grading, soil erosion, and paving for projects under the jurisdiction of the Village of Pinckney.

1.02 PUBLISHING

- A. A synopsis of the Technical Standards For Design and Construction shall be published in a newspaper of general circulation within the Village of Pinckney qualifications under State law to publish legal notices, within ten (10) days after its adoption, and the same shall be recorded and such recording authenticated by the signatures of the Village President and Clerk.

1.03 CONSTRUCTION WORKING HOURS

- A. Except as otherwise required for the safety or protection of persons or the Work or property at the Site or adjacent thereto, all construction shall be limited to the hours of 7:00 am to 7:00 pm during the regular workweek of Monday through Friday.
- B. Contractor shall not perform Work on a Saturday, Sunday, or any legal holiday.
- C. Contractor may perform Work outside regular working hours or on Saturdays, Sundays, or legal holidays only with written consent from the Village of Pinckney.

1.04 PREAMBLE

- A. This document represents the Village of Pinckney Technical Standards For Design and Construction promulgated under the Ordinances of the Village of Pinckney. It shall control all new construction or reconstructions/repairs requiring a site plan within the Village of Pinckney, or requiring new materials used to connect the water and sewer system lines where no site plan is required.
- B. Provisions for these Technical Standards For Design and Construction shall be held to be the minimum requirements adopted for promotion and preservation of public health, safety and general welfare of the Village of Pinckney. These Standards are not intended to repeal, abrogate, annul or in any manner interfere with existing regulations or laws of the Village of Pinckney, nor to conflict with any statutes of the State of Michigan or Livingston County, except that these standards shall prevail in cases where these standards impose a greater restriction than is provided by the existing statutes, laws or regulations.
- C. Contractors and their Engineers are encouraged to design facilities to provide for actual conditions encountered in their project work area. Where existing conditions warrant, designs which are more substantial than these adopted minimum standards should be developed and utilized by the Contractor.

1.05 WAIVER

- A. The requirements of these Technical Standards For Design and Construction are in place to protect the health, safety, and general welfare of all of the residents of the Village of Pinckney. If for some reason the strict letter of these standards cannot be followed due to circumstances beyond the control of Contractor, then any one of the Technical Standard requirements may be waived with the written consent of the Village Council after consulting the Village Engineer or qualified Village Agent. A waiver can only be evaluated in cases involving practical difficulties or unnecessary hardships, when the applicant demonstrates the following:

1. That the alleged practical difficulties or hardships, or both, are exceptional and peculiar to the subject property, and result from physical conditions that do not generally exist throughout the Village of Pinckney.
 2. That failure to grant the waiver will deprive the property owner of its reasonable use as enjoyed by other property owners in the same district. This shall include substantially more than mere inconvenience and/or inability to attain a higher financial return.
 3. That allowing the waiver will result in substantial justice being done, considering the public benefits intended to be secured by the standards, the individual hardships that will be suffered by failure to grant the waiver, and the rights of others whose property would be affected by approval of the waiver, if applicable.
 4. That the waiver will be consistent with the purpose and intent of the standards, will not be contrary to the public interest, and will not injure the public or private rights of others.
 5. That the conditions and circumstances on which the waiver request is based have not been self-created by the property owner.
 6. That the waiver will not constitute a special privilege inconsistent with the limitations upon other properties in the Village of Pinckney, and shall constitute the minimum deviation that allow for a reasonable use of the property.
- B. When a Contractor seeks a waiver, the following should be noted:
1. All waiver requests should be submitted in writing.
 2. It is recommended that the need for waivers is evaluated and requested in the early stages of the site plan review submittal process.
 3. All costs incurred by the Village of Pinckney for the professional review of a waiver request and the re-review of the site plan due to incorporation of the waiver shall be the sole responsibility of the Contractor. This cost is not part of a general preliminary/final/construction cost review escrows.

1.06 COORDINATION WITH UTILITY COMPANIES

- A. The Contractor shall carefully and thoroughly check with the owners of all necessary utilities before and during construction operations so that damages to utilities may be avoided and grade conflicts are adjusted in advance of construction operations to prevent delays.
- B. The Contractor shall notify "Miss Dig" at 800-482-7171 a minimum of Seventy-two (72) hours before any excavation or work,

1.07 TRAFFIC CONTROL

- A. Contractor shall furnish and install all necessary devices for traffic control as required by the Michigan Manual of Uniform Traffic Control Devices (MMUTCD), latest revision thereof.

1.08 SAFETY OFFICER

- A. It is the Contractor's responsibility to comply with all current Federal, State, and Local safety regulations where applicable including confined space regulations for new construction. The Village of Pinckney and its Village Engineer or qualified Village Agent will not oversee the Contractor's operations from the standpoint of safety and are not obligated to act as the Contractor or Subcontractor's safety officer.

1.09 EXISTING INFORMATION

- A. Prior to starting proposed utility design, the Contractor is encouraged to make use of maps and information available at the Village of Pinckney Offices regarding the existing utilities. It shall be the Contractor's sole responsibility to verify the existing utility location information provided by Village Engineer or qualified Village Agent.

1.10 SOIL EROSION AND SEDIMENT CONTROL

- A. Soil Erosion and Sediment Control measures shall be in compliance with the latest edition of the Livingston County Drain Commissioner requirements and clearly shown with details on the Final Site Plan.

<https://www.livgov.com/drain/Pages/procedures.aspx>

1.11 PRE-CONSTRUCTION MEETING

- A. A pre-construction meeting shall be held prior to the start of all construction of projects totaling in excess of \$5,000.00 or at the discretion of the Village Engineer or qualified Village Agent.
- B. The pre-construction meeting shall be in accordance with Section 01 30 00 - Administrative Requirements.

1.12 BONDS

- A. A Performance/Maintenance and Guarantee Bond in conformance with 01 31 00 - Sample Performance and Maintenance and Guarantee Bond shall be posted by Contractor prior to the beginning of construction to ensure complete construction of structures and development of the land area as proposed and approved.
- B. Bond shall be posted for the Estimated cost of Improvements as defined in Section 00 71 00 - Definitions, and may be reduced in proportion to the amount of work accomplished or the amount of land left undisturbed upon recommendation of Village Engineer or qualified Village Agent.

END OF SECTION

SECTION 00 71 00

DEFINITIONS

PART 1 GENERAL

1.01 REFERENCE STANDARDS

- A. Pinckney Code of Ordinances 152.026 - Performance Guarantee - Chapter 152 - Zoning; 2005.

1.02 DEFINITIONS

A. **Balance of the Contract Price:**

The total cost of work not completed under the Construction Contract and included on the approved Estimated Cost of Improvements.

B. **Contract Price:**

The total cost of work under the Construction Contract and included on the approved Estimated Cost of Improvements.

C. **Construction Contract:**

The agreement between the Owner and Contractor, including all Contract Documents and changes made to the agreement and the Contract Documents.

D. **Contract Documents:**

All documents that comprise the agreement between the Owner and Contractor including, but not limited to, approved Final Site Plan, approved Estimated Cost of Improvements, approved Change Proposals, approved Performance Guarantee, approved Insurance Policies, these Technical Standards For Design and Construction, etc.

E. **Contractor:**

Proprietor or his/her Authorized Agent including; property owner, developer, construction contractor, applicant, design engineer, etc.

F. **Contractor Default:**

Failure of the Contractor, which has not been remedied or waived, to perform or otherwise to comply with a material term of the Construction Contract.

G. **Effective date of the Contract:**

The date, indicated in the Construction Contract, on which the Contract becomes effective. This is the date of Final Site Plan Approval unless another date is selected by Owner.

H. **Engineer:**

Village Engineer or qualified Village Agent appointed by Owner.

I. **Estimated Cost of Improvements:**

As defined in the Pinckney Code of Ordinances 152.026 - Performance Guarantee.

J. **Final Completion:**

The date set by the Owner on which all work has been completed and all required documentation has been submitted and approved.

K. Improvements:

As defined in the Pinckney Code of Ordinances 152.026 - Performance Guarantee.

L. Owner:

Village of Pinckney. The term "Owner" shall apply to all work included in the Estimated Cost of Improvements and does not mean that the Owner has any obligation to own or maintain said work or assume any liability for said work.

M. Performance Guarantee:

As defined in the Pinckney Code of Ordinances 152.026 - Performance Guarantee.

N. Progress Schedule:

A schedule, prepared and maintained by Contractor, describing the sequence and duration of the activities comprising Contractor's plan to accomplish the Work within the Contract Times.

O. Schedule of Submittals:

A schedule, prepared and maintained by Contractor, of required submittals and the time requirements for Village Engineer or qualified Village Agent's review of the submittals and the performance of related construction activities.

P. Site:

Lands or areas indicated in the Contract Documents as being furnished by Owner upon which the Work is to be performed, including rights-of-way and easements, and such other lands furnished by Owner which are designated for the use of Contractor.

Q. Substantial Completion:

The time at which the Work (or a specified part thereof) has progressed to the point where, in the opinion of Village Engineer or qualified Village Agent, the Work (or a specified part thereof) is sufficiently complete, in accordance with the Contract Documents, so that the Work (or a specified part thereof) can be utilized for the purposes for which it is intended. The terms "substantially complete" and "substantially completed" as applied to all or part of the Work refer to Substantial Completion thereof.

R. Work:

The entire construction or the various separately identifiable parts thereof required to be provided under the Contract Documents. Work includes and is the result of performing or providing all labor, services, and documentation necessary to produce such construction; furnishing, installing, and incorporating all materials and equipment into such construction; and may include related services such as testing, start-up, and commissioning, all as required by the Contract Documents.

END OF SECTION

SECTION 01 20 01
EASEMENT REQUIREMENTS

PART 1 GENERAL

1.01 SECTION INCLUDES

- A. General easement requirements.
- B. Wording and language for plats, condominiums and site plans.
- C. Required easement widths for buried and open facilities.

1.02 REFERENCE STANDARDS

- A. Michigan Public Act 451 of 1994 - Natural Resources and Environmental Protection Act; 1994.

1.03 EASEMENTS

A. General:

- 1. All easements shall be in a Village of Pinckney approved recordable format.
- 2. Legal descriptions and easement drawings are required.
- 3. Easement drawings shall be signed and sealed by a Land Surveyor registered in the State of Michigan.
- 4. No utilities or related components such as drain fields (septic areas), are allowed within the drainage easements.
- 5. Additional easements for surface drainage may be required by Village Engineer or qualified Village Agent.
- 6. All costs of easement document recording shall be the responsibility of Contractor.

B. Notification/Format:

- 1. Wording relative to easement information shown on the plat, condominium Exhibit B drawings, or site plan shall be as specifically required by the Village of Pinckney.
- 2. The location and purpose of easements should be clearly described in subdivision deed restrictions or condominium master deeds, or other property that requires easements.
- 3. Language shall be included within the subdivision property deed restriction or condominium master deed that clearly notifies property owners of the presence of facilities and accompanying easements, as well as restrictions on use or modification of these areas.

C. Maintenance:

- 1. Water, sewer, retention and detention basin, or other storm water management facilities shall have sufficient easements for maintenance purposes.
- 2. Easements shall be sized and located to accommodate access and operation of equipment spoils deposition, and other activities including those identified in the development's storm water system maintenance plan.
- 3. All easements located outside of paved areas shall include a drivable surface approved by the Village Engineer or qualified Village Agent.

D. Width:

- 1. Minimum easement widths for new watermains, sanitary sewer, and storm water systems are provided below.

2. Easements shall be situated in such a way as to allow maximum maintenance, repair, and reconstruction access (for example, by offsetting them from the centerline). Utility offset requirements shall be determined by the Village Engineer or qualified Village Agent.
3. In general, easements widths will conform to the following:
 - a. Open channel and watercourses (e.g. a definable streambed): A minimum of 50 feet total width. An additional width may be required in some cases, including but not limited to water courses and floodplains regulated under Michigan Public Act 451 of 1994; sandy soils, steep slopes, and at access points from road crossings.
 - b. Backlot drainage (open swales): a minimum 30 feet total width.
 - c. Easement width for all storm sewer, sanitary sewer, and watermain shall conform to the following table. Burial depths are to the invert of the proposed pipe:

<u>Burial (ft)</u>	<u>Easement Width</u>	<u>Centerline Offset</u>
0-7.0	40 ft	10 ft
7.1-12	50 ft	15 ft
12.1-17	60 ft	20 ft
>17.1	70 ft	25 ft

- d. There shall be a 10 foot separation and a minimum of a 50 foot wide easement where water and sewer utilities are parallel.
- e. The minimum easement area for retention and detention basins shall encompass the entire basin and include a minimum of a 15 foot wide area from the top of slope to the outside of the basin.
- f. A 15 foot wide access easement will be required for all retention and detention basins.
- g. Underground retention and detention system easement requirements will be determined on a case-by-case basis by Village Engineer or qualified Village Agent.

END OF SECTION

SECTION 01 20 02
MAINTENANCE AGREEMENT REQUIREMENTS

PART 1 GENERAL

1.01 SECTION INCLUDES

- A. Sanitary monitoring manhole agreement requirements.
- B. Fire hydrant agreement requirements.
- C. Stormwater operation and maintenance agreement requirements.
- D. Driveway culvert agreement requirements.
- E. Grease and oil interceptors, grit separators, and other interceptor/separator/comminutor devices.

1.02 GENERAL

- A. **Agreement Form/Execution:**
 - 1. All agreements both as to form and content shall be subject to the approval of the Village of Pinckney's legal counsel.
 - 2. Legal descriptions and easement drawings shall be reviewed and approved by the Village of Pinckney Surveyor.
 - 3. Sample agreements are available from the Village of Pinckney Clerk upon request.
 - 4. Agreements shall be executed by Contractor and the recorded original submitted to the Village of Pinckney prior to release of Performance Bond.

1.03 MAINTENANCE AGREEMENTS

- A. **Sanitary Monitoring Manhole Agreement:**
 - 1. A Monitoring Manhole Agreement shall be required for all monitoring manholes.
 - 2. Adequate maintenance access from public or private right-of-way to the manhole shall be reserved.
- B. **Private Fire Hydrant Maintenance Agreement:**
 - 1. A Fire Hydrant Maintenance Agreement shall be required for all private hydrants.
 - 2. Adequate maintenance access from public or private right-of-way to the hydrant shall be reserved.
- C. **Stormwater Operation and Maintenance Agreement:**
 - 1. A Stormwater Operation and Maintenance Agreement shall be required of all detention/retention basin systems.
 - 2. Adequate maintenance access from public or private right-of-way to stormwater basin shall be reserved.
 - 3. The access shall be on a 20 percent slope or less; stabilized to withstand the passage of heavy equipment and must provide direct access to both the forebay and the riser/outlet.
- D. **Driveway Culvert Agreement:**
 - 1. A Driveway Culvert Agreement shall be required for all driveway culverts.

2. Agreements shall be executed and submitted to the Village of Pinckney concurrent with driveway permit application.

E. Grease and oil interceptors, grit separators, and other interceptor/separator device Agreement:

1. A grease and oil interceptors, grit separators, and other interceptor/separator device Agreement shall be required for all devices.
2. Adequate maintenance access from public or private right-of-way to the device shall be reserved.

END OF SECTION

SECTION 01 20 03

SANITARY SEWER SYSTEM DESIGN REQUIREMENTS

PART 1 GENERAL

1.01 SECTION INCLUDES

- A. Gravity and forcemain sewer design requirements.
- B. Monitoring Manhole requirements.
- C. Building sewer requirements.
- D. Grease and Oil Interceptor, Grit Separator, and other interceptor/separator/comminutor device requirements.

1.02 RELATED REQUIREMENTS

- A. Section 33 05 13 - Manholes and Structures: Sanitary manhole materials, configuration and installation requirements.
- B. Section 33 06 00 - Trace Wire and Locator Tape: Trace wire product materials and installation requirements.
- C. Section 33 09 01 - Installation and Acceptance Testing of Pipe and Accessories: Sanitary sewer pipe installation and field quality control.
- D. Section 33 31 13 - Sanitary Sewer Piping: Gravity sanitary sewer piping materials.
- E. Section 33 31 23 - Sanitary Force Main Piping: Pressurized sanitary piping materials.
- F. Section 33 32 13 - Packaged Wastewater Pumping Stations: Pump station requirements.
- G. Section 48 80 03 - Water Softener Dry Well

1.03 REFERENCE STANDARDS

- A. MDOT Standard Specifications for Construction - Section 701 - Portland Cement Concrete for Structures; 2012.
- B. Michigan Plumbing Code - Chapter 10 - Traps, Interceptors and Separators; 2015.
- C. Michigan Public Act 451 of 1994 - Natural Resources and Environmental Protection Act; 1994.
- D. Pinckney Code of Ordinances 52.22 - Industrial Users - Chapter 52 - Sewers; 2005.
- E. Pinckney Code of Ordinances 52.24 - Building Sewer and Connections - Chapter 52 - Sewers; 2005.
- F. Pinckney Code of Ordinances 52.25 - Use of Public Sewers - Chapter 52 - Sewers; 2005.
- G. Recommended Standards for Wastewater Facilities - 10 States Standards; 2014.
- H. State Plane Coordinate System - MI83-SIF; Latest Edition.

1.04 SANITARY SEWER DESIGN CRITERIA

- A. **General:**
 - 1. The Recommended Standards for Wastewater Facilities and Michigan Public Act 451 of 1994 shall be followed for the design of sanitary sewers unless more stringent requirements are found herein.

2. A Baseline Monitoring Report (BMR) is required in accordance with Pinckney Code of Ordinances 52.22 - Industrial Users

B. Sewer Design Computations:

1. Sewer design flow computations shall be submitted to Village Engineer or qualified Village Agent for approval with an area wide plan of the area to be serviced.
2. Developmental phases, present and future, with acreages and offsite areas contributing, shall be shown with the number of lots included.

C. Sewer Capacity:

1. Sewer capacities shall be based upon 400 gallons per capita per day for laterals and 300 gallons per capita per day for trunks.
2. Existing sewer capacity must be taken into account in the sewer computations and design to assure that available capacity is present for the proposed development.

D. Design Population:

1. For residential developments of single-family homes, design population shall be at least 3.5 persons per household.
2. In developments for housing of other types and institutions, commercial, and industrial developments, studies shall be made to establish equivalent population values.

E. Minimum Size:

1. Minimum size for public sanitary sewer shall be 8 inch diameter.

F. Minimum/Maximum Design Velocity:

1. Minimum design velocity for sanitary sewers shall be 2 feet per second with pipe flowing full.
2. Maximum design velocity for sanitary sewers shall be 12 feet per second with the pipe flowing full.
3. Following are minimum grades for each size of pipe:

Pipe Diameter	Minimum Grades (%)
6 inch	1.00
8 inch	0.40
10 inch	0.32
12 inch	0.22
15 inch	0.15
18 inch	0.12

G. Sewer Location:

1. Sanitary sewers shall be located to best conform to the layout of existing facilities.
2. In streets where no pattern has been established, sewers shall generally be located approximately 8 feet from the property line on the side opposite the watermains.
3. Minimum horizontal separation of 10 feet shall be provided between watermains, sanitary sewers and storm sewers.

H. Depth of Sewers:

1. Minimum depth of cover to top of pipe shall be 4 feet.
2. Generally, the minimum depth of sewer below the finished grade of the building to be served shall be 10 feet (or 8.5 feet at the right-of-way line) unless otherwise approved by Village Engineer or qualified Village Agent.
 - a. Deep setbacks or unusual conditions may require greater depths.
3. The invert of house connections at the point of terminus shall be constructed such that it adequately provides basement sewer service unless otherwise approved by Village Engineer or qualified Village Agent.
4. The maximum depth to invert of any sanitary sewer shall not exceed the depth recommended by the manufacturer for each size and class of pipe.

I. Manhole Location:

1. Manholes shall be placed at intervals not greater than 400 feet.
2. Manholes shall be placed at every change of grade, direction, pipe size, sewer junction and/or at the discretion of Village Engineer or qualified Village Agent.
3. Whenever possible, manholes shall be placed out of the asphalt or concrete surfaces such as paved streets or sidewalks, etc.

J. Monitoring Manholes:

1. Monitoring manholes are required for all leads from commercial or industrial developments.
2. The location and number of manholes is at the discretion of Village Engineer or qualified Village Agent.

K. Manhole Structure:

1. Drop manhole connections shall be used whenever a sewer enters a manhole at an elevation more than 24 inches above manhole invert.
2. Whenever there is an increase in pipe size, the grades shall match at a line 0.8 of the diameters above the inverts.
3. An allowance of 0.10 foot in grade shall be made for loss of head through a manhole.
4. The minimum inside diameter of all manholes shall be 48 inches.
5. The manhole(s) at the lowest end of the proposed system shall include a 2 foot sump for acceptance testing purposes.
 - a. Sump shall be filled with concrete once acceptance testing is complete.
 - b. The requirement to provide a sump may be waived by Village Engineer or qualified Village Agent where testing is to be done by either low pressure air testing or exfiltration testing.
6. Special approved wet area manholes with precast rubber gasket type pipe fittings and lockdown rubber gasket type manhole covers shall be required in areas of high ground water table and where manholes are to be located in or adjacent to drainage ditches, low areas and flood plains.

L. Forcemains:

1. Pipe for forcemains shall be designed to withstand both internal pressures and external trench and live loads. Design computations shall be submitted by Contractor for review and approval.
2. Mechanical Restraints for HDPE shall be approved by Village Engineer or qualified Village Agent.
 - a. All HDPE to PVC transitions shall include fused transition couplings, concrete deadmen and a minimum of 5 restrained joints.
 - b. All HDPE deadmen shall include 2 electrofusion flex restraints.

- c. The length of restrained joint pipe shall be adequate to resist all design working and surge pressures to which the main will be subjected.
- 3. Forcemain cleanout structures shall be located along the length of the main at intervals not exceeding 1,000 feet unless otherwise approved by Village Engineer or qualified Village Agent.
- 4. Air release structures shall be located along the length of the main at all local high points.
- 5. Forcemain drops will be reviewed on a case-by-case basis.
- 6. Thrust Blocks:
 - a. Thrust blocks, when allowed under special circumstances only, shall be made of S3 concrete, in accordance with MDOT Standard Specifications for Construction - Section 701, and of adequate size and shape to resist all design working and surge pressures to which the main will be subjected.

M. Building Sewers:

- 1. All Building Sewers shall be designed and installed in accordance with the Pinckney Code of Ordinances 52.24 - Building Sewer and Connections.
- 2. Unless otherwise approved by Village Engineer or qualified Village Agent due to exceptional circumstances, construction of the building sewer, from public sewer to property line for each fronting parcel which the sewer is designed to serve, shall be included with construction of each sanitary sewer.
- 3. Building sewer shall extend a minimum of 10 feet beyond the property line for new construction or to the right-of-way line for reconstruction or as approved by Village Engineer or qualified Village Agent.
- 4. Wyes, Tees, and Risers: (See also Section 33 09 01 - Installation and Acceptance Testing of Pipe and Accessories Paragraph 3.05- Installation- Stubs and Service Leads)
 - a. Each building site shall include a service lead.
 - b. Risers shall be constructed at the right-of-way line unless otherwise approved by Village Engineer or qualified Village Agent.
 - c. Where the cover over sanitary sewer to finished grade is more than 12 feet, risers shall be installed.
 - d. Location of the wye or tee shall be marked from the downstream manhole on the record sewer plans prepared and also located in State Plane Coordinate System.
 - e. Where the water table is high, the riser shall end at a depth of 1 foot above the water table unless otherwise directed by Village Engineer or qualified Village Agent.
- 5. All building sewers shall be equipped with a check valve if required by the Livingston County Building Department to prevent sewage from back-flowing into any establishment.
- 6. Lead Size:
 - a. Lead size for single family homes shall be 6 inch diameter unless otherwise approved by the Village Engineer or qualified Village Agent.
 - b. Lead size for commercial and industrial developments shall be approved by Village Engineer or qualified Village Agent.
- 7. Grinder Pumps:
 - a. Grinder pump connections will be approved on a case-by-case basis.
- 8. Connections other than Sanitary:
 - a. Downspouts, weep tile footing drains, water softener devices and sump pump discharges or any other conduit that carries stormwater, groundwater, brine water shall not be allowed to discharge into the building sewer or lateral sewer.

9. Cleanouts shall be installed within 10 feet of the foundation, and every 100 feet of pipe, and at all bends. Cleanouts are required for all new construction.
10. All newly installed building sewers are required to be televised to ensure clear flow and joint integrity prior to inspection approval.

N. Grease and Oil Interceptors and Grit Separators and other interceptor/separator/comminutor devices:

1. All new industrial uses shall install a grease interceptor, oil interceptor and/or grit separator for use upstream of the sanitary service lead connection if required by Michigan Plumbing Code or Pinckney Code of Ordinances 52.25 - Use of Public Sewers or other interceptor/separator/comminutor devices as directed by the Village Engineer or qualified Village Agent. Devices shall be approved by Village Engineer or qualified Village Agent.

O. Dry Well:

1. All residential, commercial, and industrial buildings shall install a dry well in accordance with Pinckney Code of Ordinances 52.24 - Building Sewer and Connections and Section 48 80 03 - Water Softener Dry Well.

P. Trace Wire:

1. Trace wire and locator tape shall be installed on all sanitary mains and laterals.

END OF SECTION

SECTION 01 20 04
WATER SYSTEM DESIGN REQUIREMENTS

PART 1 GENERAL

1.01 SECTION INCLUDES

- A. Water system design requirements.

1.02 RELATED REQUIREMENTS

- A. Section 33 05 13 - Manholes and Structures: Gate well manhole materials, configuration and installation requirements.
- B. Section 33 06 00 - Trace Wire and Locator Tape: Trace wire product materials and installation requirements.
- C. Section 33 09 01 - Installation and Acceptance Testing of Pipe and Accessories: Water pipe installation and field quality control.
- D. Section 33 14 16 - Water Piping: Water piping materials.

1.03 REFERENCE STANDARDS

- A. MDOT Standard Specifications for Construction - Section 701 - Portland Cement Concrete for Structures; 2012.
- B. Michigan Public Act 399 of 1976 - Safe Drinking Water Act; 1976.
- C. Pinckney Code of Ordinances 51.06 - Connections to Water Supply System - Chapter 51 - Water; 2005.
- D. Pinckney Code of Ordinances 51.07 - Water Meters - Chapter 51 - Water; 2008.
- E. Pinckney Code of Ordinances 51.08 - Cross-Connections Prohibited - Chapter 51 - Water; 2005.
- F. Recommended Standards for Waterworks - 10 States Standards; 2012.

1.04 WATERMAIN DESIGN CRITERIA:

A. General:

- 1. The Recommended Standards for Waterworks and Michigan Public Act 399 of 1976 shall be followed for the design of water systems unless more stringent requirements are found herein.

B. Watermain Design Computations:

- 1. Contractor shall submit for approval design computations for single-family residential development based on average daily flow rate plus a fire demand of 1,500 gallons per minute and a residual of 20 psi (pounds per square inch) at the most remote hydrant.
- 2. Designs for fire protection flow for multi-family, commercial and industrial developments will be reviewed on an individual basis depending on type of building construction used.

C. Hydrant Flow Testing:

- 1. Contractor shall engage a qualified firm to perform hydrant flow and pressure testing.
 - a. Testing shall be witnessed by Village Engineer or qualified Village Agent and associated costs will be deducted from the escrow account.
 - b. Testing results and recommendations shall be submitted for review.

D. Minimum Size:

1. Minimum size for public watermain shall be 8 inch diameter.

E. Depth of Watermains:

1. Depth of cover shall be 5.5 feet minimum.
2. Where a dip must be placed in a main in order to pass under another utility, the length of the deeper main shall be kept to a minimum employing methods approved by Village Engineer or qualified Village Agent.

F. Watermain Location:

1. Mains shall be located so as to best conform to the layout of existing facilities.
2. In streets where no pattern has been established, mains shall generally be located approximately 8 feet from the property line.
3. A minimum horizontal separation of 10 feet shall be provided between watermains, sanitary sewers, and storm sewers.

G. Fire Hydrant Location:

1. Generally, fire hydrants in single-family residential developments shall be spaced such that they will be not more than 250 feet from the farthest corner of any proposed building.
2. Distance between hydrants in the road right-of-way shall not exceed 250 feet.
3. Spacing of hydrants around multiple dwellings, commercial, industrial, and/or manufacturing establishments shall be determined by consultation with Village Engineer or qualified Village Agent and Fire Marshall.
4. Generally, hydrants shall be located approximately 12 feet from the property line.
5. Fire hydrants shall be installed on the end of all dead end mains.
6. Fire hydrants shall be located at least 25 feet from any exterior wall of a masonry building, and at least 50 feet from any exterior wall other than masonry unless otherwise directed by Fire Marshall.
7. Plans shall be submitted to the Fire Marshall for final approval of hydrant locations.
8. Plans shall indicate finished grade of all hydrants.

H. Gate Valve Location:

1. In general, gate valves on cross connecting mains shall be located so that no single break requires more than 800 feet of main to be out of service.
2. Gate valves on feeders 12 inches or larger, gate valves shall be spaced not more than 1,500 feet apart.
3. Gate valves shall be arranged so that any section can be isolated by closing not more than 3 gate valves, with a maximum of 30 parcels or units out of service.
4. In general, gate vales shall be installed on every leg of a tee or cross.
5. Gate valves shall generally be located such that they will not be in the sidewalks, driveways, or in roads.
6. Valves and hydrants shall be placed on all dead end mains for future extension.
7. Branch valves 12 inch diameter or smaller may be direct bury and include a valve box.
 - a. All other valves, including tapping valves of any diameter, shall be installed in gate wells

I. Joint Restraint:

1. Locking gaskets are required at all valves, bends, tees, hydrant shoes, plugs or caps and crosses in all directions where necessary to prevent lateral movement of the pipe.
2. Mechanical restraints may be allowed for fittings (e.g. tapping sleeves) that are not manufactured with a locking gasket joint restraint option. All mechanical restraints must be approved by Village Engineer or qualified Village Agent prior to installation.
3. Pipe restraint shall be per the manufacturer's recommendation.
4. Thrust Blocks:
 - a. Thrust blocks, when allowed under special circumstances only, shall be made of S3 concrete, in accordance with MDOT Standard Specifications for Construction - Section 701, and of adequate size and shape to resist all design working and surge pressures to which the main will be subjected.

J. Backflow Prevention:

1. All lawn sprinkler, irrigation and fire protection systems or any other systems that could backflow into the distribution system shall be equipped with suitable backflow prevention in compliance with Michigan Public Act 399 of 1976, Pinckney Code of Ordinances 51.08 - Cross-Connections Prohibited, and the Livingston County Building Department requirements where they are connected to the municipal water supply system.

K. Connections to the Public Water Supply System:

1. All connections to the Village of Pinckney public water supply system shall be in accordance with Pinckney Code of Ordinances 51.06 - Connections to Water Supply System and Section 33 14 16 - Water Piping.

L. Meters:

1. All connections to the Village of Pinckney public water supply system shall be metered in accordance with Pinckney Code of Ordinances 51.07 - Water Meters and Section 33 14 16 - Water Piping.

M. Special Fittings and Adaptors:

1. Special machined faced parts shall be provided where required to connect to existing mains.
 - a. Shop drawings shall be submitted for approval.
2. Wherever adaptors are required to properly connect proposed watermain with existing pipe of other material or manufacturer, the nominal inside diameter (I.D.) of the adaptors shall be of the same size as the nominal diameter of the pipe connected thereto.

N. Trace Wire:

1. Trace wire and locator tape shall be installed on all water mains and services.

END OF SECTION

SECTION 01 20 05

STORM WATER SYSTEM DESIGN REQUIREMENTS

PART 1 GENERAL

1.01 SECTION INCLUDES

- A. Storm water system design requirements.

1.02 RELATED REQUIREMENTS

- A. Section 33 05 13 - Manholes and Structures: Manhole materials, configuration and installation requirements.
- B. Section 33 09 01 - Installation and Acceptance Testing of Pipe and Accessories: Sewer pipe installation and field quality control.
- C. Section 33 42 11 - Storm Sewer Piping: Storm piping materials.

1.03 REFERENCE STANDARDS

- A. Livingston County Drain Commissioner - Procedures and Design Criteria for Stormwater Management Systems and Soil Erosion and Sedimentation Control Program; 2005.

1.04 STORM WATER MANAGEMENT DESIGN CRITERIA:

A. Standards:

- 1. All storm water management systems, storm sewer design, retention and detention basins, and soil erosion and sedimentation control plans shall meet the standards of the Livingston County Drain Commissioner and these Technical Standards For Design and Construction. The Livingston County Drain Commissioner's Office will approve all storm water management facilities. <https://www.livgov.com/drain/Pages/procedures.aspx>

B. Detention/Retention Necessity:

- 1. All new land developments shall be equipped with detention/retention facilities unless otherwise approved by Village Engineer or qualified Village Agent and the Livingston County Drain Commissioner's Office.

C. Offsite Easements:

- 1. The storm water runoff from all proposed Site developments shall be collected and conveyed by means of storm sewers and/or swales to approved points of discharge.
 - a. Where an approved point of discharge is not available on the Site, Contractor shall make such off-site drainage improvements as are necessary to provide positive drainage to an approved outlet, as determined by Village Engineer or qualified Village Agent.
 - b. Such improvements shall be located in an easement secured by Contractor.
- 2. Easement size and form shall be in accordance with Section 01 20 01 - Easement Requirements.

D. Privately Owned Systems:

- 1. All privately owned storm drainage systems and detention/retention facilities shall be properly maintained to the satisfaction of the Village of Pinckney.
 - a. The cost for such maintenance shall be at the Contractor's expense in accordance with the Stormwater Operation and Maintenance Agreement.

E. Runoff from and to Adjacent Sites:

1. All proposed developments shall provide for overland flow of storm water from adjacent properties where the existing off-site land slopes to the site.
2. Detention/retention provided for the flow from off-site lands shall accommodate at least the amount of runoff from the land in the undeveloped state or more as determined by Village Engineer or qualified Village Agent.
3. Storm water runoff rate in excess of that generated from undeveloped property shall not flow onto adjacent lands of others.

1.05 STORM SEWER DESIGN CRITERIA

A. Storm Sewer Design Computations:

1. A complete set of storm sewer design computations shall accompany every set of final plans submitted for review.
2. Hydraulic gradients shall be shown as part of all storm sewer profiles.

B. Minimum Size:

1. Minimum size for storm sewer shall be 12 inch diameter.

C. Minimum/Maximum Design Velocity:

1. The following are permissible slopes for each pipe size. A Manning's n value of 0.013 shall be used unless otherwise approved by Village Engineer or qualified Village Agent:

Pipe Size (inches)	Minimum Grade (percent)	Desirable Grade Range (percent)		Maximum Grade (percent)
		2.5 ft/sec	4 ft/sec	
12	0.32	0.78	3.12	4.88
15	0.24	0.58	2.32	3.62
18	0.20	0.46	1.82	2.84
21	0.16	0.38	1.48	2.30
24	0.14	0.30	1.24	1.94
27	0.12	0.26	1.06	1.66
30	0.10	0.22	0.92	1.44
36	0.08	0.18	0.72	1.12
42	0.06	0.14	0.58	0.92
48	0.06	0.12	0.50	0.76
54	0.04	0.10	0.38	0.60
60	0.04	0.10	0.34	0.54
66	0.04	0.08	0.32	0.48

D. Sewer Location:

1. Storm sewers shall be located to best conform to the layout of existing facilities.
2. In streets where no pattern has been established, storm sewers shall generally be located on the road centerline.
3. Minimum horizontal separation of 10 feet shall be provided between watermains, sanitary sewers and storm sewers.

E. Depth of Storm Sewers:

1. Minimum depth of cover to top of pipe shall be 4 feet.
2. The maximum depth to invert of any storm sewer shall not exceed the depth recommended by the manufacturer for each size and class of pipe.

F. Manhole/Catch basin/Inlet Location:

1. Manholes shall be placed at intervals not greater than 400 feet.
2. Manholes shall be placed at every change of grade, direction, pipe size, sewer junction and/or at the discretion of Village Engineer or qualified Village Agent.
3. Catch basin/inlet structures in the public street right-of-way shall be spaced a maximum of 400 feet apart and a maximum of 400 feet each way from high points.
 - a. The spacing and/or number of inlet structures required to accommodate the design flows in streets and in private drives and parking areas, shall be based on a maximum of 1 cubic foot per second (cfs) per 90 square inches of opening in an inlet or catch basin cover. This equates to a depth of water over the inlet casting of 1 inch.

G. Manhole/Catch basin/Inlet Structure:

1. Generally, drops of over 2 feet at manholes, from invert of higher pipe to lower pipe, shall be avoided. Village Engineer or qualified Village Agent approval is required for any drop greater than 2 feet.
2. Whenever there is an increase in pipe size, the grades shall match at a line 0.8 of the diameters above the inverts.
3. The minimum inside diameter of all manholes, catch basins, and inlet structures shall be 48 inches.
4. All manholes shall be sized from the following table. Other pipe sizes/configurations will require Village Engineer or qualified Village Agent approval.

Inside Diameter of Structure	Maximum Pipe Size for Straight Thru Installation	Maximum Pipe Size for Right Angle Installation
48"	24" x 24"	18" x 18"
60"	36" x 36"	24" x 24"
72"	42" x 42"	36" x 36"
96"	60" x 60"	42" x 42"

a. Notes:

- 1) All dimensions are for concrete pipes.
- 2) 6 inch minimum spacing between openings in structure is required.
- 3) Special details will be required for manholes placed on pipe 60 inches in diameter and larger.

H. Open Channels:

1. The maximum velocity for grass-lined channels shall not exceed 4 feet per second. Where this velocity is exceeded, the channel shall be protected by cobble paving or other means to prevent scour approved by Village Engineer or qualified Village Agent.
2. Normally, the minimum acceptable velocity should be 1.5 feet per second.
3. Side slopes of open channels shall normally be no steeper than a 25 percent slope.
4. Where conditions dictate side slopes steeper than 25 percent, consideration should be given to slope paving or alternate stabilization and fencing approved by Village Engineer or qualified Village Agent.

I. **Rip Rap:**

1. Rip-rap sizing computations, gradation requirements, and details shall be approved by Village Engineer or qualified Village Agent.

J. **Culverts:**

1. Culvert sizing computations shall be approved by Village Engineer or qualified Village Agent.
2. Minimum size of driveway culverts shall be 12 inches.

K. **Animal Guards:**

1. Animal guards shall be required for pipe greater than 12 inches in diameter.

L. **Outlets:**

1. Where drainage outlets to Livingston County drains or natural water courses, such outlets shall be so designed as to enter the drain or watercourse at an angle of 90 degrees or less, as determined by the upstream centerline.
2. Headwalls, concrete end sections, pre-formed end sections, grouted rip-rap or specially designed outlet structures will be required.

M. **Oil and Grit Separators:**

1. Storm sewer oil and grit separators may be required at the discretion of Village Engineer or qualified Village Agent.

N. **Dry Wells:**

1. Storm sewer dry wells shall be concrete structures.
2. Dry well sizing computations and configuration shall be approved by Village Engineer or qualified Village Agent.

END OF SECTION

SECTION 01 20 06
SITE GRADING DESIGN REQUIREMENTS

PART 1 GENERAL

1.01 SECTION INCLUDES

- A. Site grading requirements for residential properties
- B. Site grading requirements for multi-family, commercial, office, and industrial properties
- C. Retaining wall design requirements.

1.02 RELATED REQUIREMENTS

- A. Section 31 22 00 - Stripping and Grading: Stripping and grading procedures.

1.03 REFERENCE STANDARDS

- A. EGLE - Michigan Department of Environment, Great Lakes, and Energy; 2019.
- B. Livingston County Drain Commissioners Office - Guide to Soil Erosion and Sedimentation Control (SESC)with Technical Specifications; 2017.
- C. Pinckney Code of Ordinances 151.27 - Use Permit Application - Chapter 151 - Wetlands and Watercourses; 1989.

1.04 GENERAL

- A. All proposed developments shall be graded such that storm water runoff will be intercepted within the boundaries of the site, collected and conducted through a storm water treatment system to an approved point of discharge.
- B. Filling and grading shall not create a barrier causing entrapment on or restriction of water from adjacent lands of others.
- C. Grading plans shall take into account the desirable natural features and the character of the land, which must be preserved where possible.
- D. No filling will be allowed in any areas of land within a proposed subdivision or other type of development which lie either wholly or in part within the floodplain of a river, stream, creek, lake or wetlands unless under the terms of a permit granted by EGLE and Pinckney Code of Ordinances 151.27 - Use Permit Application.
- E. All soil erosion and sedimentation control plans shall meet the standards of the Livingston County Drain Commissioners Office and these Technical Standards For Design and Construction. The Livingston County Drain Commissioner's Office will approve all soil erosion and sedimentation control plans.
<https://www.livgov.com/drain/Pages/erosion-permits.aspx>

1.05 GRADING REQUIREMENTS

- A. **Residential Developments:**
 - 1. Each single family residential lot shall be graded to drain away from the house by swales constructed along the lot lines.
 - 2. Swales shall discharge to a catch basin, roadway gutter, or other approved drainage course.
 - 3. Where front-to-rear drainage is utilized, the longitudinal slope along a rear yard drainage easement shall be not less than 1 percent and no greater than 6 percent.

- a. Maximum distance from a high point to an enclosed drain shall not exceed 250 feet unless otherwise approved by Village Engineer or qualified Village Agent.
4. Proposed spot elevations shall be shown at all corners for each lot.
5. The general direction of overland drainage shall be indicated on each lot by an arrow and as specified within the plan legend as "drainage arrow".
6. High and low street elevation points, slope direction (by arrow) and the location and elevation of all catch basins, inlets and drainage ditches shall be shown on the grading plan.
7. A maximum slope of 4 feet horizontal to 1 foot vertical shall not be exceeded for all terracing unless approved by Village Engineer or qualified Village Agent.
8. Grading plans shall be drawn to a scale of not more than 1" = 50'.
9. The grading plans shall show the existing 1 foot contours on site and on abutting property within 250 feet of the site boundary.
10. Proposed contours must be provided for the entire site being graded.
11. All elevations shall be to NAVD 88 datum.
12. Detail of the typical lot drainage pattern shall be shown on the grading plan with all grade control points identified.
13. In general, for streets with ditches and no curbs, elevation of the front lot line shall be at least 6 inches above the centerline of the road.
14. Acceptable temporary soil erosion control measures shall be installed, maintained and removed as directed by the Livingston County Drain Commissioners Office to prevent sedimentation of storm sewers.

B. Grading Requirements - Multi-Family, Commercial, Office & Industrial Developments:

1. Asphalt surface parking lots and roadways shall be graded to a minimum 1 percent slope.
2. Where concrete curb and gutter is to be used, the transverse slope to the gutter shall be a minimum of 1 percent for parking lots and two percent for roadway crowns.
3. Longitudinal gutter slopes shall be a minimum of 0.5 percent for concrete curb and gutter.
4. In general, pavement slopes shall not exceed 5 percent and parking lot slopes shall not exceed 4 percent unless otherwise approved by Village Engineer or qualified Village Agent.
5. All areas within 25 feet of buildings shall slope away from the building at a minimum slope of 2 percent. All other areas shall have a minimum of 1 percent slope.
6. All lawn or landscaped areas shall drain to parking lots or swales.
7. Catch basins shall be placed at all low points in parking lots and swales.

C. Retaining Walls:

1. All retaining walls shall be designed and certified by a Structural Engineer registered in the State of Michigan and be subject to review by Village Engineer or qualified Village Agent.

END OF SECTION

SECTION 01 20 07

ROADWAY, PARKING, DRIVEWAY, AND SIDEWALK DESIGN REQUIREMENTS

PART 1 GENERAL

1.01 SECTION INCLUDES

- A. Roadway standards
- B. Parking standards
- C. Driveway standards
- D. Sidewalk standards

1.02 RELATED REQUIREMENTS

- A. Section 34 01 00 - Street and other Hard Surface Improvements: Roadway, driveway and sidewalk material and installation requirements.

1.03 REFERENCE STANDARDS

- A. AASHTO GDHS - A Policy on Geometric Design of Highways and Streets; 6th Edition, 2011 (with 2013 Errata).
- B. ADA Standards - Americans with Disabilities Act (ADA) Standards for Accessible Design; 2010.
- C. ATBCB PROWAG - Proposed Accessibility Guidelines for Pedestrian Facilities in the Public Right-of-Way; 2011.
- D. LCRC SAAR - Specifications and Administrative Rules Regulating Driveways, Road Approaches, Banners and Parades on and over Highways; 2010.
- E. LCRC SFPD - Specifications for Plat Development; 2010.
- F. Livingston County Road Commission - Specifications and Administrative Rules Regulating Driveways, Road Approaches, Banners and Parades On and Over Highways; 2010.
- G. MDOT ERDM - Michigan Department of Transportation, Road Design Manual; Latest Edition.
- H. MDOT Standard Plans R-29 - Driveway Openings & Approaches and Concrete Sidewalk; Latest Edition.
- I. Pinckney Code of Ordinances 92.31 - Street Cuts and New Pavement - Chapter 92 - Streets and Sidewalks; 2000.

1.04 GENERAL

- A. The plans shall be designed and the project constructed to current AASHTO GDHS, ADA Standards, ATBCB PROWAG, MDOT ERDM, LCRC SFPD, and LCRC SAAR requirements and to the minimum standards as listed below.
 - 1. These Technical Standards For Design and Construction shall prevail in cases where they impose a greater restriction than provided by guidelines and requirements above.

1.05 ROADWAY DESIGN CRITERIA

A. Profile Scale:

- 1. Scale 1" = 40' horizontal and 1" = 4' vertical, showing the existing ground elevations and proposed grades.

B. Right-of-Way:

Technical Standards For Design
and Construction

01 20 07 - 1

ROADWAY, PARKING,
DRIVEWAY, AND SIDEWALK
DESIGN REQUIREMENTS

1. The right-of-way shall have a minimum width of 66 feet.
 2. The use of eyebrows, elbows and like designs will not be permitted without approval from Village Engineer or qualified Village Agent.
 3. The centerline of the road shall be constructed on the centerline of the right-of-way.
- C. Minimum Intersection Radii:**
1. Residential road intersections shall have a minimum radius of 25.5 feet at the back of curb.
 2. Commercial and Industrial road intersections shall have a minimum radius of 35.5 feet at the back of curb.
- D. Sight Distance:**
1. Adequate sight distances shall be maintained on all vertical and horizontal roadway curves.
- E. Minimum/Maximum Slope:**
1. The minimum slope on any roadway shall be 1 percent.
 2. The maximum slope on any roadway shall be 6 percent.
- F. Vertical/Horizontal Curves:**
1. The vertical curve shall be used at all changes in grade. No vertical curve of less than 100 feet or less than 40 times the algebraic difference in percent of slopes will be permitted.
 2. All proposed streets shall have horizontal curves with a minimum radius based on design speed but not less than 230 feet radius measured at the centerline.

1.06 ROADWAY STANDARDS:

- A. Curb and Gutter:**
1. All roads within the Village of Pinckney limits shall be paved and have curb and gutter and be to the standards as follows unless otherwise approved by Village Engineer or qualified Village Agent.
- B. Roadway Width:**
1. Residential: 31 feet wide from back of curb to back of curb with the following minimum standards:
 2. Commercial and Industrial: 37 feet wide from back of curb to back of curb with the following minimum standards:
- C. Roadway Cross Section:**
1. Residential:
 - a. 6 inches MDOT Class II subbase
 - b. 8 inches MDOT 21AA aggregate base
 - c. 2.5 inches MDOT 13A leveling course
 - d. 1.5 inches MDOT 5E3 wearing course
 2. Commercial and Industrial:
 - a. 6 inches MDOT Class II sub-base
 - b. 10 inches MDOT 21AA aggregate base
 - c. 3 inches MDOT 3E3 base course

- d. 3 inches MDOT 4E3 leveling course
- e. 2 inches MDOT 5E3 wearing course

D. Utilities Crossing Paved Streets:

- 1. All utility crossings of paved streets shall be in accordance with Pinckney Code of Ordinances 92.31 - Street Cuts and New Pavement

E. Embankment Slopes:

- 1. Roadside back slopes shall be one vertical to four horizontal (1:4), or flatter if possible, or as otherwise approved by Village Engineer or qualified Village Agent.

F. Asphalt Placement Schedule:

- 1. A note shall be added to all roadway plans stating "Contractor shall not place final course of asphalt until approved by Village Engineer or qualified Village Agent".
- 2. At a minimum, the wearing course shall not be placed for at least one winter to allow for a freeze-thaw cycle.

1.07 PARKING STANDARDS

A. On Street Parking:

- 1. No parking shall be allowed in streets in residential areas unless otherwise approved by the Village of Pinckney.
- 2. This requirement shall be included in both the subdivision deed restrictions and/or condominium master deed.

B. Commercial and Industrial Parking Lot Cross Section:

- 1. Asphalt:
 - a. 6 inches MDOT Class II subbase
 - b. 8 inches MDOT 21AA aggregate base
 - c. 2.5 inches MDOT 13A asphalt leveling course
 - d. 1.5 inches MDOT 5E3 wearing course
- 2. Heavy duty asphalt - Heavy duty asphalt shall be utilized in areas of truck traffic:
 - a. 6 inches MDOT Class II sub-base
 - b. 10 inches MDOT 21AA aggregate base
 - c. 3 inches MDOT 13A leveling course
 - d. 2 inches MDOT 4E3 wearing course
- 3. Concrete:
 - a. 6 inches MDOT Class II sub-base
 - b. 6 inches MDOT 21AA aggregate base
 - c. 7 inches MDOT Grade P1, 6.0 sack concrete, reinforced
- 4. Heavy duty concrete - Heavy duty concrete shall be utilized in areas of truck traffic:
 - a. 6 inches MDOT Class II sub-base
 - b. 8 inches MDOT 21AA limestone aggregate base

- c. 9 inches MDOT Grade P1, 6.0 sack concrete

C. Parking Lot Dimensional Requirements:

1. Parking slips shall be a minimum of 180 square feet with dimensions of (10' x 18') or (9' x 20').
2. All access roads to parking areas shall have a minimum width of 31 feet from back of curb to back of curb.
3. All primary traffic ways within parking lots shall have a minimum width of 31 feet.
4. All secondary and tertiary traffic ways within parking lots shall have a minimum width of 24 feet.

1.08 DRIVEWAY STANDARDS

A. General:

1. It is the purpose of this section to establish standards for the location and design of driveways that can be used for new construction in undeveloped areas and for redevelopment of existing developed areas.
 - a. The objectives of these requirements are to:
 - 1) Reduce the frequency of conflicts between vehicular movements
 - 2) Expand the spacing between potential conflict points
 - 3) Improve traffic safety
 - 4) Provide more efficient traffic flow
2. All drive approaches within the Village of Pinckney right-of-way shall be concrete with a configuration in accordance with Section 34 01 00 - Street and other Hard Surface Improvements.

B. Lanes per Driveway:

1. The number of driveway lanes shall be based on analysis of expected trip generation and peak turning movements.
2. If expected left turns exiting the subject site exceeds 100 per hour, two egress lanes (left and right/thru) shall be provided.

C. Turn Prohibition:

1. Left turns may be prohibited at the discretion of the Village of Pinckney into or out of any driveway under the following conditions:
 - a. Inadequate corner clearance
 - b. Inadequate sight distance
 - c. Inadequate driveway spacing

D. Relationship to Opposing Driveways:

1. To the extent desirable and reasonably possible, driveways shall be aligned with driveways on the opposite side of the street.

E. Sight Distance:

1. Adequate sight distance shall be ensured for all vehicles exiting from a proposed development.
2. If certain movements cannot be made safely, then they shall be prohibited or joint access with adjoining properties shall be encouraged.

3. Site distance must meet the requirements of the Livingston County Road Commission.
<http://www.livingstonroads.org/Portals/5/docs/old/DrivewaySpecs2010.pdf>

F. Driveway Slope:

1. No portion of a driveway approach within the public street right-of-way shall have a slope greater than 10 percent or the latest MDOT Standard Plans R-29.

G. Driveway Angle:

1. All driveway approaches shall enter perpendicular to the existing roadway unless otherwise approved by Village Engineer or qualified Village Agent.

H. Driveway Culverts

1. Village Engineer or qualified Village Agent shall determine whether or not a culvert is required and, if required, shall approve the diameter and length of the culvert.
2. Contractor shall design, furnish and install the culvert.
3. Contractor shall maintain in perpetuity the culvert in reasonable condition.
4. Culverts shall be kept clean and free of debris at all times.
5. The minimum length of a culvert may be determined as the width of the approach over the culvert plus 6 feet each side.
 - a. The maximum fore slope is one vertical to three horizontal (1:3).
 - b. Village Engineer or qualified Village Agent reserves the right to require longer culverts and flatter fore slopes, depending on site specific conditions.
 - c. The use of sloped culvert end sections required.
 - d. The use of culvert headwalls is prohibited.
 - e. The enclosure of ditches beyond the end of normal culvert length must be approved by Village Engineer or qualified Village Agent.
6. Culverts shall be installed in line with and on the same grade as the road ditch.
 - a. Notwithstanding, Village Engineer or qualified Village Agent may require that the Contractor re-grade the ditch at his/her expense in order to provide adequate cover over the culvert.
 - b. The cover, or depth of material over the culvert, should be equal to or greater than the diameter of the culvert.
7. A minimum 12 inch diameter culvert is required.
8. All culverts shall be corrugated metal pipes made with steel of the proper gauge corresponding to its diameter, as shown below.

Diameter (inches)	Gauge No.
12 - 24	16
30 - 36	14
42 - 54	12
60 - 72	10

- a. If Contractor wishes to install a culvert of material other than that above, approval must be obtained from Village Engineer or qualified Village Agent prior to permit issuance.

I. Drive Location:

1. Non-residential ingress and egress requirements.

a. Driveway spacing:

- 1) The minimum spacing allowed between a proposed driveway and all other driveways (located on the same side of the public street which the proposed driveway abuts or adjoins) or street intersections shall be in accordance with the following standards:

Posted Speed Limit on Adjacent Public Street*	Minimum Driveway Spacing (feet)**
30 mph or less	100 ft.
35	160 ft.
40	210 ft.
45 or over	300 ft.

* Traffic speeds are based on posted speeds as of the effective date of these Technical Standards For Design and Construction. In the event the posted speed limit is changed, the minimum spacing requirement in effect on the adoption date of these Technical Standards For Design and Construction shall remain in force, unless amended at a later date by the Village of Pinckney Council.

** Spacing requirements are based on average vehicle acceleration and deceleration rates and are considered the minimum distances necessary to maintain safe traffic operation. The required spacing shall be measured from the centerline of the proposed driveway to the centerline of the nearest existing driveway or the edge of the right-of-way or easement of the nearest intersecting street.

b. In the event that a particular parcel or parcels lack sufficient road frontage to meet the spacing requirement, Contractor may:

- 1) Seek a waiver from the Village of Pinckney, but in no case shall the waiver permit less separation than permitted in the next lowest spacing requirement, as shown in the table of spacing requirements;
- 2) Obtain authorization from the adjacent property owner(s) to establish a shared driveway between the properties
- 3) Obtain a cross-access easement to use an existing driveway on adjacent property.

J. Number of Driveways per Parcel:

1. A maximum of one driveway opening shall be permitted to a parcel or lot from each abutting street.
2. One driveway is allowed for residential property, held in one piece, with frontage less than or equal to 66 feet. One additional residential driveway may be permitted where frontage exceeds 100 feet.
3. The Village of Pinckney may permit one additional driveway entrance along any street on which the parcel frontage exceeds 400 feet.
4. In the case of dual one-way driveways, one pair may be used per 250 feet of frontage. Only one pair of one-way drives shall be permitted per street frontage.

K. Property Clearance:

1. All portions of a driveway, including the radii, shall be located entirely within the Contractor's property lines and extended at right angles to the centerline of the road.

2. The minimum distance between the property line and the nearest edge of the driveway (excluding radii) shall be equal to the side yard setback or as required by the Livingston County Road Commission.

L. Commercial Driveway Corner Clearance:

1. The minimum corner clearance distance between the centerline of a proposed driveway and the edge of the right-of-way or easement of an intersecting street shall be 150 feet. Waivers will be considered on a case-by-case basis.
2. Traffic movements into or out of any driveway, the centerline of which is located within 250 feet of the edge of the right-of-way or easement of a signalized street intersection, shall be limited to right-turns in and right-turns out only.

M. Joint Driveways:

1. When two properties share a common property line, a joint driveway may be approved by Village Engineer or qualified Village Agent.
2. Joint driveways shall have a width of not greater than 30 feet unless otherwise approved by Village Engineer or qualified Village Agent.

N. Driveway Drainage:

1. Driveways shall be sloped to prevent ponding within the public road right-of-way.
2. Positive drainage to the roadway must be maintained unless otherwise approved by Village Engineer or qualified Village Agent.

O. Residential Driveway Materials:

1. New homes being constructed shall include a driveway surfaced with a material which is equal to or better than the surface of the roadway which it joins.
 - a. At a minimum, driveways shall be constructed with at least the materials listed below.
2. Existing homes that apply for a new hard surface driveway or apply to resurface an existing driveway shall also meet the standards listed below:
3. Asphalt Driveways:
 - a. 6 inches of MDOT 21AA aggregate base.
 - b. 3 inches of MDOT 36A bituminous surface.
4. Concrete Driveways:
 - a. 6 inches of MDOT 21AA aggregate base.
 - b. 6 inches of MDOT Grade P1, 6.0 sack concrete, non-reinforced.

P. Commercial Driveway Materials:

1. Heavy duty concrete shall be utilized for all commercial driveways within the road right-of-way with the following minimum standards:
 - a. 6 inches MDOT Class II sub-base
 - b. 8 inches MDOT 21AA limestone aggregate base
 - c. 10 inches MDOT Grade P1, 6.0 sack concrete, non-reinforced.
2. Materials utilized for all commercial driveways outside the road right-of-way shall meet the standards required in subsection 1.07.B above.

1.09 SIDEWALK STANDARDS

A. General:

1. All sidewalk within the Village of Pinckney right-of-way shall be concrete with a configuration in accordance with Section 34 01 00 - Street and other Hard Surface Improvements.
2. Sidewalks shall be constructed on all road frontages within the Village of Pinckney unless otherwise waived by the Village of Pinckney Council.

B. Sidewalk Width:

1. Sidewalks shall be a minimum 5 feet wide.

C. Sidewalk Thickness:

1. Sidewalks shall be a minimum of 4 inches thick.
2. All residential walks shall be 6 inches thick at all drive crossings plus 5 feet either side of the drive crossing.
3. All commercial and industrial walks shall be 10 inches thick at all drive crossings plus 5 feet either side of the drive crossing.
4. Sidewalk ramps adjacent to streets and driveways shall be 7 inches thick.

D. Sidewalk Location:

1. All new sidewalks (not re-reconstructed) shall be located 1 foot inside the right-of-way line.
2. Whenever an existing sidewalk that does not conform to the above location criteria is reconstructed, repaired or replaced, such replacement must be brought into conformance unless otherwise approved by Village Engineer or qualified Village Agent.

E. Sidewalk Slope:

1. All sidewalks shall conform to the established grade of the street unless otherwise directed by Village Engineer or qualified Village Agent.
2. The surface grade of the finished sidewalk shall have minimum cross slope of 1 percent and a maximum cross slope of 2 percent.
3. Sidewalk shall slope towards the street unless otherwise approved by Village Engineer or qualified Village Agent.

END OF SECTION

SECTION 01 30 00
ADMINISTRATIVE REQUIREMENTS

PART 1 GENERAL

1.01 SECTION INCLUDES

- A. General administrative requirements.
- B. Preconstruction meeting.
- C. Progress meetings.
- D. Submittals for review, information, and project closeout.
- E. Number of copies of submittals.
- F. Requests for Information (RFI) procedures.
- G. Submittal procedures.

1.02 RELATED REQUIREMENTS

- A. Section 01 60 00 - Product Requirements: General product requirements.
- B. Section 01 70 00 - Execution and Closeout Requirements: Additional coordination requirements.
- C. Section 01 78 00 - Closeout Submittals: Project record documents; operation and maintenance data; warranties and bonds.

1.03 GENERAL ADMINISTRATIVE REQUIREMENTS

- A. Conform to requirements of Section 01 70 00 - Execution and Closeout Requirements for coordination of execution of administrative tasks with timing of construction activities.
- B. Make the following types of submittals to Village Engineer or qualified Village Agent:
 - 1. Requests for Information (RFI).
 - 2. Requests for substitution.
 - 3. Shop drawings, product data, and samples.
 - 4. Test and inspection reports.
 - 5. Design data.
 - 6. Manufacturer's instructions and field reports.
 - 7. Change Proposals.
 - 8. Progress Schedules, Schedule of Submittals, Schedule of Values.
 - 9. Coordination drawings.
 - 10. Correction Punch List and Final Correction Punch List for Substantial Completion.
 - 11. Closeout submittals.

PART 2 PRODUCTS - NOT USED

PART 3 EXECUTION

3.01 PRECONSTRUCTION MEETING

- A. Contractor shall schedule a meeting after Final Site Plan approval.
- B. Attendance Required:
 - 1. Owner
 - 2. Village Engineer or qualified Village Agent
 - 3. Contractor:
 - a. Proprietor
 - b. Project Manager
 - c. Site Superintendent
 - d. Site Foreman
 - e. Subcontractors
- C. Attendance Requested:
 - 1. Utility Companies
 - 2. Drain Commissioner
 - 3. Fire Marshall
 - 4. Police Chief
- D. Agenda:
 - 1. Submission of executed bonds and insurance certificates.
 - 2. Submission of list of Subcontractors, list of products, Progress Schedule, Schedule of Submittals, and Schedule of Values.
 - 3. Scheduling.
 - 4. Use of premises by Owner and Contractor.
 - 5. Owner's requirements and occupancy prior to completion.
 - 6. Construction facilities and controls.
 - 7. Temporary utilities.
 - 8. Security and housekeeping procedures.
 - 9. Procedures for testing.
 - 10. Procedures for maintaining record documents.
 - 11. Requirements for start-up of equipment.
 - 12. Inspection and acceptance of materials and equipment put into service during construction period.

- E. Village Engineer or qualified Village Agent will record minutes and distribute copies to participants, with copies to Owner, Contractor, participants, and those affected by decisions made.

3.02 PROGRESS MEETINGS

A. Contractor shall:

1. Schedule and administer meetings throughout progress of the work at maximum monthly intervals.
2. Make arrangements for meetings, prepare agenda with copies for participants, preside at meetings.
3. Attendance Required:
 - a. Owner
 - b. Village Engineer or qualified Village Agent
 - c. Contractor
 - 1) Proprietor
 - 2) Project Manager
 - 3) Site Superintendent
 - 4) Site Foreman
 - 5) Major Subcontractors
 - 6) Subcontractors and/or Suppliers required for coordination of projected schedule
4. Agenda:
 - a. Review minutes of previous meetings.
 - b. Review of work progress.
 - c. Field observations, problems, and decisions.
 - d. Identification of problems that impede, or will impede, planned progress.
 - e. Review of Schedule of Submittals and status of submittals.
 - f. Review of RFIs log and status of responses.
 - g. Maintenance of Progress Schedule.
 - h. Corrective measures to regain projected schedules.
 - i. Planned progress during succeeding work period.
 - j. Coordination of projected progress.
 - k. Maintenance of quality and work standards.
 - l. Effect of proposed changes on Progress Schedule and coordination.
 - m. Other business relating to Work.
5. Record minutes and distribute copies within 5 business days after meeting to participants, with copies to Owner, Village Engineer or qualified Village Agent, participants, and those affected by decisions made.

3.03 REQUESTS FOR INFORMATION (RFI)

A. Definition: A request seeking one of the following:

1. An interpretation, amplification, or clarification of some requirement of Contract Documents arising from inability to determine from them the exact material, process, or system to be installed; or when the elements of

construction are required to occupy the same space (interference); or when an item of Work is described differently at more than one place in the Contract Documents.

2. A resolution to an issue which has arisen due to field conditions and affects design intent.
- B. Whenever possible, request clarifications at the next appropriate project progress meeting, with response entered into meeting minutes, rendering unnecessary the issuance of a formal RFI.
- C. Preparation: Prepare an RFI immediately upon discovery of a need for additional information or interpretation of the Contract Documents.
1. Prepare a separate RFI for each specific item.
 - a. Review, coordinate, and comment on requests originating with Subcontractors and/or materials Suppliers.
 - b. Do not forward requests which solely require internal coordination between Subcontractors.
 2. Prepare in a format and with content acceptable to Owner.
 3. Combine RFI and its attachments into a single electronic file. PDF format is preferred.
- D. Reason for the RFI: Prior to initiation of an RFI, carefully study all Contract Documents to confirm that information sufficient for their interpretation is definitely not included.
1. Include in each request Contractor's signature attesting to good faith effort to determine from the Contract Documents information requiring interpretation.
 2. Unacceptable Uses for RFIs: Do not use RFIs to request the following:
 - a. Approval of submittals (use procedures specified elsewhere in this section).
 - b. Approval of substitutions (see Section - 01 60 00 - Product Requirements).
 3. Improper RFIs: Requests not prepared in conformance to requirements of this section, and/or missing key information required to render an actionable response. They will be returned without a response, with an explanatory notation.
 4. Frivolous RFIs: Requests regarding information that is clearly indicated on, or reasonably inferable from, the Contract Documents, with no additional input required to clarify the question. They will be returned without a response, with an explanatory notation.
- E. Content: Include identifiers necessary for tracking the status of each RFI, and information necessary to provide an actionable response.
1. Official Project name and number, and any additional required identifiers established in Contract Documents.
 2. Owner's, Village Engineer or qualified Village Agent's, and Contractor's names.
 3. Discrete and consecutive RFI number, and descriptive subject/title.
 4. Issue date, and requested reply date.
 5. Reference to particular Contract Document(s) requiring additional information or interpretation. Identify pertinent drawing and detail number and/or specification section number, title, and paragraph(s).
 6. Annotations: Field dimensions and/or description of conditions which have engendered the request.
 7. Contractor's suggested resolution:
 - a. A written and/or a graphic solution, to scale, is required in cases where clarification of coordination issues is involved, for example; routing, clearances, and/or specific locations of work shown diagrammatically in Contract Documents.

- b. If applicable, state the likely impact of the suggested resolution on Contract Times or the Contract Prices.
- F. Attachments: Include sketches, coordination drawings, descriptions, photos, submittals, and other information necessary to substantiate the reason for the request.
- G. RFI Log: Prepare and maintain a tabular log of RFIs for the duration of the project.
 - 1. Indicate current status of every RFI. Update log promptly and on a regular basis.
 - 2. Note dates of when each request is made, and when a response is received.
 - 3. Highlight items requiring priority or expedited response.
 - 4. Highlight items for which a timely response has not been received to date.
 - 5. Identify and include improper or frivolous RFIs.

3.04 SUBMITTAL SCHEDULE

- A. Submit to Village Engineer or qualified Village Agent for review a Schedule of Submittals in tabular format.
 - 1. Coordinate with Contractor's Progress Schedule and Schedule of Values.
 - 2. Format schedule to allow tracking of status of submittals throughout duration of construction.
 - 3. Arrange information to include scheduled date for initial submittal, specification number and title, submittal category (for review or for information), description of item of work covered, and role and name of subcontractor.

3.05 SUBMITTALS FOR REVIEW

- A. When the following are specified in individual sections or identified below, submit them for review:
 - 1. Product data.
 - 2. Shop drawings.
 - 3. At a minimum, submittals shall include the following:
 - a. Water:
 - 1) Pipe material.
 - 2) Bedding and backfill material.
 - 3) Precast gate well structure cut sheet and related components.
 - 4) Manhole frames and covers.
 - 5) Pipe joint material.
 - 6) Service Lead Material.
 - 7) Meters.
 - 8) Curb boxes and appurtenances.
 - 9) Valves and valve boxes.
 - 10) Hydrants.
 - 11) Fittings.
 - 12) Tapping valves and sleeves.
 - 13) Thrust blocks if permitted.
 - 14) Joint restraints.

- b. Sanitary Sewer:
 - 1) Pipe material.
 - 2) Bedding and backfill material.
 - 3) Precast manhole structure cut sheet and related components.
 - 4) Manhole frames and covers.
 - 5) Pipe joint material.
 - 6) Service lead material.
 - 7) Pump station and appurtenances.
 - 8) Forcemain and appurtenances.
 - 9) Grease traps.
 - 10) Testing Manholes
 - 11) Shredders
 - 12) Oil separator
 - 13) Grit separator
- c. Storm Sewer:
 - 1) Pipe material.
 - 2) Bedding and backfill material.
 - 3) Precast manhole, inlet, and catch basin structure cut sheet and related components.
 - 4) Frames and covers.
 - 5) Pipe joint material.
 - 6) Edge drain material and appurtenances.
 - 7) Animal guard and end section.
 - 8) Culvert material.
 - 9) Underground detention/retention systems.
 - 10) Gas/oil/sediment treatment units.
 - 11) Detention/retention basin, stand pipe and connections.
- d. Miscellaneous:
 - 1) Bedding and backfill material.
 - 2) Soil erosion (silt fence/mulch blanket and appurtenances/inlet filters/rip rap).
 - 3) Fencing.
 - 4) Retaining walls.
 - 5) Asphalt and concrete mix design.
 - 6) Aggregate base analysis.
 - 7) Rebar/wire mesh.
 - 8) ADA detectable warning devices.
 - 9) Synthetic fabric/geogrid material.
 - 10) Signage.
 - 11) Dry well/no salt generating softeners.
 - 12) Boardwalks.

- 13) Locator Tape, Tracer wire and appurtenances.
- B. Submit to Village Engineer or qualified Village Agent for review for the limited purpose of checking for conformance with information given and the design concept expressed in the Contract Documents.
- C. After review, provide copies and distribute in accordance with SUBMITTAL PROCEDURES article below and for record documents purposes described in Section 01 78 00 - Closeout Submittals.

3.06 SUBMITTALS FOR INFORMATION

- A. When the following are specified in individual sections or identified below, submit them for information:
 1. Design data.
 2. Certifications.
 - a. Contractor shall provide a final letter to the Owner certifying that all Work for the project has been constructed in general conformance with the approved Final Site Plans. The Contractor shall identify deviations from the approved plans, if any. Village Engineer or qualified Village Agent may require that Contractor's registered Engineer submit for a waiver from identified deviations, if warranted.
 - b. Water:
 - 1) Certification from Contractor's testing company that the pipe bedding material meets specification.
 - 2) Certification from manufacturer that the pipe and appurtenances meet specification.
 - 3) Certification from manufacturer that the gate well structures and appurtenances meet specification.
 - 4) Certification from manufacturer that the meters and appurtenances meet specification.
 - 5) Confirmation that the pipe meets the hydrostatic testing and disinfection specification.
 - 6) Certification from manufacturer that all valves, hydrants, fittings, valve boxes, and materials for service leads meet specification.
 - 7) Certification from Contractor's testing company that all structural backfill areas were compacted to the minimum density requirement of the specifications with an approved material.
 - c. Sanitary Sewer:
 - 1) Certification from Contractor's testing company that the pipe bedding material meets specification.
 - 2) Certification from manufacturer that the pipe and appurtenances meet specification.
 - 3) Certification from manufacturer that the manhole structures and appurtenances meet specification.
 - 4) Confirmation that the pipe meets the deflection testing specification.
 - 5) Confirmation that the pipe meets the infiltration, exfiltration, and air testing specification.
 - 6) Confirmation that the horizontal and vertical alignment of the pipe meets specification.
 - 7) Certification from manufacturer that all castings and covers meet specification.
 - 8) Certification from Contractor's testing company that all structural backfill areas were compacted to the minimum density requirement of the specifications with an approved material.
 - d. Storm Sewer:
 - 1) Certification from Contractor's testing company that the pipe bedding material meets specification.
 - 2) Certification from manufacturer that the pipe, catch basin and manhole structures and appurtenances meet specification.

- 3) Certification from the Design Engineer that all detention basins, retention basins, and restricted outlets are sized in accordance with the latest Livingston County Drain Commissioner's Standards.
 - 4) Certification from Contractor's testing company that all structural backfill areas were compacted to the minimum density requirement of the specification with an approved material.
- e. Roadways:
- 1) Certification from Contractor's testing company that the granular sub-base material meets specification.
 - 2) Certification from Contractor's testing company that the aggregate base material meets specification.
 - 3) Certification from Contractor's testing company that the asphalt material meets specification.
 - 4) Certification from Contractor's testing company that the concrete for curb and gutter or pavement slabs meets specification.
 - 5) Certification from the Design Engineer that the horizontal alignment, vertical alignment, width of road and all material depths were constructed in accordance with the approved as-built plans.
 - 6) Certification from Contractor's testing company that all structural backfill areas were compacted to the minimum density requirement of the specifications with an approved material.
 - 7) Certification from Contractor's testing company that all curb and sidewalks meets specification.
3. Test reports.
 4. Inspection reports.
 5. Manufacturer's instructions.
 6. Manufacturer's field reports.
 7. Other types indicated.

3.07 NUMBER OF COPIES OF SUBMITTALS

- A. Electronic Documents: Submit one electronic copy in PDF format; an electronically-marked up file will be returned. Create PDFs at native size and right-side up; illegible files will be rejected.

3.08 SUBMITTAL PROCEDURES

- A. General Requirements:
 1. Use a single transmittal for related items.
 2. Submit separate packages of submittals for review and submittals for information, when included in the same specification section.
 3. Transmit using approved form.
 - a. Use Contractor's form, subject to prior approval by Village Engineer or qualified Village Agent.
 4. Sequentially identify each item. For revised submittals use original number and a sequential numerical suffix.
 5. Identify: Project; Contractor; Subcontractor or Supplier; pertinent drawing and detail number; and specification section number and article/paragraph, as appropriate on each copy.
 6. Apply Contractor's stamp, signed or initialed certifying that review, approval, verification of products required, field dimensions, adjacent construction work, and coordination of information is in accordance with the requirements of the Work and Contract Documents.

- a. Submittals from sources other than Contractor, or without Contractor's stamp will not be acknowledged, reviewed, or returned.
- 7. Deliver each submittal on date noted in Schedule of Submittals, unless an earlier date has been agreed to by all affected parties, and is of the benefit to the project.
 - a. Send submittals in electronic format via email to Village Engineer or qualified Village Agent.
- 8. Schedule submittals to expedite the Project, and coordinate submission of related items.
 - a. For each submittal for review, allow 15 days excluding delivery time to and from Contractor.
 - b. For sequential reviews involving Village Engineer or qualified Village Agent's consultants, Owner, or another affected party, allow an additional 7 days.
- 9. Identify variations from Contract Documents and product or system limitations that may be detrimental to successful performance of the completed Work.
- 10. Provide space for Contractor and Village Engineer or qualified Village Agent review stamps.
- 11. When revised for resubmission, identify all changes made since previous submission.
- 12. Distribute reviewed submittals. Instruct parties to promptly report inability to comply with requirements.
- 13. Incomplete submittals will not be reviewed, unless they are partial submittals for distinct portion(s) of the Work, and have received prior approval for their use.
- B. Product Data Procedures:
 - 1. Submit concurrently with related Shop Drawing submittal.
- C. Shop Drawing Procedures:
 - 1. Prepare accurate, drawn-to-scale, original shop drawing documentation by interpreting the Contract Documents and coordinating related Work.
 - 2. Generic, non-project-specific information submitted as Shop Drawings do not meet the requirements for Shop Drawings.

3.09 SUBMITTAL REVIEW

- A. Submittals for Review: Village Engineer or qualified Village Agent will review each submittal, and approve, or take other appropriate action.
- B. Submittals for Information: Village Engineer or qualified Village Agent will not acknowledge receipt, and take no other action.
- C. Village Engineer or qualified Village Agent's actions will be reflected by marking each returned submittal using virtual stamp on electronic submittals.
 - 1. Notations may be made directly on submitted items and/or listed on appended Submittal Review cover sheet.
- D. Village Engineer or qualified Village Agent's actions on items submitted for review:
 - 1. Authorizing purchasing, fabrication, delivery, and installation:
 - a. "Approved", or language with same legal meaning.
 - b. "Approved as Noted, Resubmission not required", or language with same legal meaning.
 - 1) At Contractor's option, submit corrected item, with review notations acknowledged and incorporated.
 - c. "Approved as Noted, Resubmit for Record", or language with same legal meaning.

- 1) Resubmit corrected item, with review notations acknowledged and incorporated. Resubmit separately, or as part of Project record documents.
 - 2) Non-responsive resubmittals may be rejected.
2. Not Authorizing fabrication, delivery, and installation:
- a. "Revise and Resubmit".
 - 1) Resubmit revised item, with review notations acknowledged and incorporated.
 - 2) Non-responsive resubmittals may be rejected.
 - b. "Rejected".
 - 1) Submit item complying with requirements of the Contract Documents.
- E. Village Engineer or qualified Village Agent's actions on items submitted for information:
1. Items for which no action was taken:
 - a. "Received" - to notify Contractor that the submittal has been received for record only.
 2. Items for which action was taken:
 - a. "Reviewed" - no further action is required from Contractor.

END OF SECTION

SECTION 01 32 00
SAMPLE CHANGE PROPOSAL

(FOR MINOR CHANGES AS DEFINED IN PINCKNEY CODE OF ORDINANCES 152.394)

Date of Issuance: _____ Change Proposal No. _____

Effective Date _____

Owner: Village of Pinckney

Contractor: _____

Contractor's Project No.: _____

Engineer: Village Engineer or qualified Village Agent

Project: _____

Contract Name: _____

The Contract will be modified upon approval of this Change Proposal:

Description: _____

Attachments: *[List Documents Supporting Change]*

A. Requested By: _____

B. BY: _____ [] Recommended [] Denied by Village Engineer
Contractor (Auth. Signature) [] Approved [] Denied by Zoning Administrator

C. Title: _____ Reason (If Denied) _____

D. Date: _____

END OF SECTION

SECTION 01 40 00
QUALITY REQUIREMENTS

PART 1 GENERAL

1.01 SECTION INCLUDES

- A. Submittals.
- B. Quality assurance.
- C. References and standards.
- D. Testing and inspection agencies and services.
- E. Control of installation.
- F. Tolerances.
- G. Manufacturers' field services.
- H. Defect Assessment.

1.02 RELATED REQUIREMENTS

- A. Section 01 30 00 - Administrative Requirements: Submittal procedures.
- B. Section 01 60 00 - Product Requirements: Requirements for material and product quality.

1.03 REFERENCE STANDARDS

- A. IAS AC89 - Accreditation Criteria for Testing Laboratories; 2010.

1.04 SUBMITTALS

- A. See Section 01 30 00 - Administrative Requirements, for submittal procedures.
- B. Design Data: Submit for Village Engineer or qualified Village Agent's knowledge for the limited purpose of assessing conformance with information given and the design concept expressed in the Contract Documents, or for Owner's information.
- C. Test Reports: After each test/inspection, promptly submit two copies of report to Village Engineer or qualified Village Agent and to Contractor.
 - 1. Include:
 - a. Date issued.
 - b. Project title and number.
 - c. Name of inspector.
 - d. Date and time of sampling or inspection.
 - e. Identification of product and specifications section.
 - f. Location in the Project.
 - g. Type of test/inspection.
 - h. Date of test/inspection.

- i. Results of test/inspection.
 - j. Conformance with Contract Documents.
 - k. When requested by Village Engineer or qualified Village Agent, provide interpretation of results.
- D. Certificates: When specified in individual specification sections, submit certification by the manufacturer and Contractor to Village Engineer or qualified Village Agent, in quantities specified for Product Data.
 - 1. Indicate material or product conforms to or exceeds specified requirements. Submit supporting reference data, affidavits, and certifications as appropriate.
 - 2. Certificates may be recent or previous test results on material or product, but must be acceptable to Village Engineer or qualified Village Agent.
- E. Manufacturer's Instructions: When specified in individual specification sections, submit printed instructions for delivery, storage, assembly, installation, start-up, adjusting, and finishing, for the Owner's information. Indicate special procedures, perimeter conditions requiring special attention, and special environmental criteria required for application or installation.
 - 1. Manufacturer's Instructions: When specified in individual specification sections, submit printed instructions for delivery, storage, assembly, installation, start-up, adjusting, and finishing, for the Owner's information.
 - 2. Indicate special procedures, perimeter conditions requiring special attention, and special environmental criteria required for application or installation.
- F. Manufacturer's Field Reports:
 - 1. Submit reports to Village Engineer or qualified Village Agent.
 - 2. Submit for information for the limited purpose of assessing conformance with information given and the design concept expressed in the Contract Documents.

1.05 QUALITY ASSURANCE

- A. Testing Agency Qualifications:
 - 1. Prior to start of Work, submit agency name, address, and telephone number, and names of full time specialist and responsible officer.
 - 2. Provide documentation showing testing laboratory is accredited under IAS AC89.

1.06 REFERENCES AND STANDARDS

- A. For products and workmanship specified by reference to a document or documents not included in the Contract Documents, also referred to as reference standards, comply with requirements of the standard, except when more rigid requirements are specified or are required by applicable codes.
- B. Conform to reference standard of date of issue current on date of Contract Documents, except where a specific date is established by applicable code.
- C. Obtain copies of standards where required by product specification sections.
- D. Maintain copy at Site during submittals, planning, and progress of the specific Work, until Substantial Completion.
- E. Should specified reference standards conflict with Contract Documents, request clarification from Village Engineer or qualified Village Agent before proceeding.
- F. Neither the contractual relationships, duties, or responsibilities of the parties in Contract nor those of Village Engineer or qualified Village Agent shall be altered from the Contract Documents by mention or inference otherwise in any reference document.

1.07 TESTING AND INSPECTION AGENCIES AND SERVICES

- A. Contractor shall employ and pay for services of an independent testing agency to perform specified testing.
- B. Employment of agency in no way relieves Contractor of obligation to perform Work in accordance with requirements of Contract Documents.

PART 2 PRODUCTS - NOT USED

PART 3 EXECUTION

3.01 CONTROL OF INSTALLATION

- A. Monitor quality control over suppliers, manufacturers, products, services, Site conditions, and workmanship, to produce Work of specified quality.
- B. Comply with manufacturers' instructions, including each step in sequence.
- C. Should manufacturers' instructions conflict with Contract Documents, request clarification from Village Engineer or qualified Village Agent before proceeding.
- D. Comply with specified standards as minimum quality for the Work except where more stringent tolerances, codes, or specified requirements indicate higher standards or more precise workmanship.
- E. Have Work performed by persons qualified to produce required and specified quality.
- F. Verify that field measurements are as indicated on Shop Drawings or as instructed by the manufacturer.
- G. Secure products in place with positive anchorage devices designed and sized to withstand stresses, vibration, physical distortion, and disfigurement.

3.02 TOLERANCES

- A. Monitor fabrication and installation tolerance control of products to produce acceptable Work. Do not permit tolerances to accumulate.
- B. Comply with manufacturers' tolerances. Should manufacturers' tolerances conflict with Contract Documents, request clarification from Village Engineer or qualified Village Agent before proceeding.
- C. Adjust products to appropriate dimensions; position before securing products in place.

3.03 TESTING AND INSPECTION

- A. See individual specification sections for testing and inspection required.
- B. Contractor Responsibilities:
 - 1. Provide adequate samples of materials proposed to be used that require testing, along with proposed mix designs.
 - 2. Cooperate with laboratory personnel, and provide access to the Work.
 - 3. Provide incidental labor and facilities:
 - a. To provide access to Work to be tested/inspected.
 - b. To obtain and handle samples at the Site or at source of products to be tested/inspected.
 - c. To facilitate tests/inspections.

- d. To provide storage and curing of test samples.
- 4. Notify Village Engineer or qualified Village Agent and laboratory 72 hours prior to expected time for operations requiring testing/inspection services.
- C. Re-testing required because of non-conformance to specified requirements shall be performed by the same agency on instructions by Village Engineer or qualified Village Agent.

3.04 MANUFACTURERS' FIELD SERVICES

- A. When specified in individual specification sections or when required by Village Engineer or qualified Village Agent, require material or product suppliers or manufacturers to provide qualified staff personnel to observe Site conditions, conditions of surfaces and installation, quality of workmanship, start-up of equipment, as applicable, and to initiate instructions when necessary.
- B. Report observations and Site decisions or instructions given to applicators or installers that are supplemental or contrary to manufacturers' written instructions.

3.05 DEFECT ASSESSMENT

- A. Replace Work or portions of the Work not conforming to specified requirements.

END OF SECTION

SECTION 01 50 00
TEMPORARY FACILITIES AND CONTROLS

PART 1 GENERAL

1.01 SECTION INCLUDES

- A. Temporary sanitary facilities.
- B. Vehicular access and parking.
- C. Waste removal facilities and services.

1.02 TEMPORARY SANITARY FACILITIES

- A. Provide and maintain required facilities and enclosures. Provide at time of project mobilization.
- B. Maintain daily in clean and sanitary condition.

1.03 VEHICULAR ACCESS AND PARKING

- A. Comply with regulations relating to use of streets and sidewalks, access to emergency facilities, and access for emergency vehicles.
- B. Coordinate access and haul routes with governing authorities and Owner.
- C. Provide and maintain access to fire hydrants, free of obstructions.
- D. Provide means of removing mud from vehicle wheels before entering streets.
- E. Provide temporary parking areas to accommodate construction personnel. When Site space is not adequate, provide additional off-site parking.

1.04 WASTE REMOVAL

- A. Provide waste removal facilities and services as required to maintain the Site in clean and orderly condition.
- B. Provide containers with lids. Remove trash from Site periodically.
- C. If materials to be recycled or re-used on the project must be stored on-site, provide suitable non-combustible containers; locate containers holding flammable material outside the structure unless otherwise approved by the authorities having jurisdiction.

1.05 REMOVAL OF UTILITIES, FACILITIES, AND CONTROLS

- A. Remove temporary utilities, equipment, facilities, materials, prior to Date of Substantial Completion inspection.
- B. Clean and repair damage caused by installation or use of temporary Work.

END OF SECTION

SECTION 01 51 00
TEMPORARY UTILITIES

PART 1 GENERAL

1.01 SECTION INCLUDES

- A. Temporary Utilities: Provision of water.

1.02 TEMPORARY WATER SERVICE (WHEN NECESSARY)

- A. Cost of Water Used: By Contractor.
- B. Connect to existing water source.
 - 1. The Village of Pinckney will provide a meter and backflow preventer and be reimbursed for cost of water used. **Obtain FEE SCHEDULE for current water rates from the Village of Pinckney Clerk.**

END OF SECTION

SECTION 01 60 00
PRODUCT REQUIREMENTS

PART 1 GENERAL

1.01 SECTION INCLUDES

- A. General product requirements.
- B. Transportation, handling, storage and protection.
- C. Product option requirements.

1.02 RELATED REQUIREMENTS

- A. Section 01 40 00 - Quality Requirements: Product quality monitoring.

1.03 SUBMITTALS

- A. See Section 01 30 00 - Administrative Requirements, for submittal procedures.

PART 2 PRODUCTS

2.01 NEW PRODUCTS

- A. Provide new products unless specifically required or permitted by the Contract Documents.

2.02 PRODUCT OPTIONS

- A. Products specified by reference standards or by description only: Use any product meeting those standards or description.
- B. Products specified by naming one or more manufacturers: Use a product of one of the manufacturers named and meeting specifications, no options or substitutions allowed unless named product is no longer available.

PART 3 EXECUTION

3.01 TRANSPORTATION AND HANDLING

- A. Package products for shipment in manner to prevent damage; for equipment, package to avoid loss of factory calibration.
- B. If special precautions are required, attach instructions prominently and legibly on outside of packaging.
- C. Coordinate schedule of product delivery to designated prepared areas in order to minimize Site storage time and potential damage to stored materials.
- D. Transport and handle products in accordance with manufacturer's instructions.
- E. Transport materials in covered trucks to prevent contamination of product and littering of surrounding areas.
- F. Promptly inspect shipments to ensure that products comply with requirements, quantities are correct, and products are undamaged.
- G. Provide equipment and personnel to handle products by methods to prevent soiling, disfigurement, or damage, and to minimize handling.

3.02 STORAGE AND PROTECTION

- A. Designate receiving/storage areas for incoming products so that they are delivered according to installation schedule and placed convenient to work area in order to minimize waste due to excessive materials handling and misapplication.
- B. Store and protect products in accordance with manufacturers' instructions.
- C. Store with seals and labels intact and legible.
- D. Store sensitive products in weather tight, climate controlled enclosures in an environment favorable to product.
- E. For exterior storage of fabricated products, place on sloped supports above ground.
- F. Protect products from damage or deterioration due to construction operations, weather, precipitation, humidity, temperature, sunlight and ultraviolet light, dirt, dust, and other contaminants.
- G. Comply with manufacturer's warranty conditions, if any.
- H. Cover products subject to deterioration with impervious sheet covering. Provide ventilation to prevent condensation and degradation of products.
- I. Store loose granular materials on solid flat surfaces in a well-drained area. Prevent mixing with foreign matter.
- J. Prevent contact with material that may cause corrosion, discoloration, or staining.
- K. Provide equipment and personnel to store products by methods to prevent soiling, disfigurement, or damage.
- L. Arrange storage of products to permit access for inspection. Periodically inspect to verify products are undamaged and are maintained in acceptable condition.

END OF SECTION

SECTION 01 70 00
EXECUTION AND CLOSEOUT REQUIREMENTS

PART 1 GENERAL

1.01 SECTION INCLUDES

- A. Examination, preparation, and general installation procedures.
- B. Pre-installation meetings.
- C. Cleaning and protection.
- D. Closeout procedures, including Contractor's Correction Punch List.

1.02 SUBMITTALS

- A. See Section 01 30 00 - Administrative Requirements, for submittal procedures.
- B. Survey Work: Submit name, address, and telephone number of Surveyor before starting survey Work.
 - 1. On request, submit documentation verifying accuracy of survey work.
 - 2. Submit surveys and survey logs for the project record.
- C. Demolition Plan: Submit demolition plan as specified by OSHA and local authorities.
 - 1. Indicate extent of demolition, removal sequence, bracing and shoring, and location and construction of barricades and fences. Include design drawings and calculations for bracing and shoring.
 - 2. Identify demolition firm and submit qualifications.
 - 3. Include a summary of safety procedures.

1.03 COORDINATION

- A. Coordinate scheduling, submittals, and Work of the individual specification sections to ensure efficient and orderly sequence of installation of interdependent construction elements.
- B. Notify affected utility companies and comply with their requirements.
- C. Coordinate completion and clean-up of Work of separate sections.

PART 2 PRODUCTS - NOT USED

PART 3 EXECUTION

3.01 EXAMINATION

- A. Examine and verify specific conditions described in individual specification sections.
- B. Verify that utility services are available, of the correct characteristics, and in the correct locations.

3.02 PREINSTALLATION MEETINGS

- A. When required in individual specification sections Contractor shall:
 - 1. Convene a preinstallation meeting at [the Site] prior to commencing Work of the section.

2. Require attendance of parties directly affecting, or affected by, Work of the specific section.
3. Notify Village Engineer or qualified Village Agent 3 business days in advance of meeting date.
4. Prepare agenda and preside at meeting:
 - a. Review conditions of examination, preparation and installation procedures.
 - b. Review coordination with related Work.
5. Record minutes and distribute copies within 5 business days after meeting to participants, with copies to Village Engineer or qualified Village Agent, Owner, participants, and those affected by decisions made.

3.03 GENERAL INSTALLATION REQUIREMENTS

- A. Install products as specified in individual sections, in accordance with manufacturer's instructions and recommendations, and so as to avoid waste due to necessity for replacement.
- B. Make vertical elements plumb and horizontal elements level, unless otherwise indicated.

3.04 PROTECTION OF INSTALLED WORK

- A. Protect installed Work from damage by construction operations.
- B. Provide special protection where specified in individual specification sections.

3.05 CLOSEOUT PROCEDURES

- A. Notify Village Engineer or qualified Village Agent when Work is considered ready for Village Engineer or qualified Village Agent's Substantial Completion inspection.
- B. Conduct Substantial Completion inspection and create Final Correction Punch List containing Village Engineer or qualified Village Agent's and Contractor's comprehensive list of items identified to be completed or corrected and submit to Village Engineer or qualified Village Agent.
- C. Correct items of Work listed in Final Correction Punch List and comply with requirements for access to Owner-occupied areas.
- D. Accompany Engineer on Contractor's preliminary final inspection.
- E. Complete items of Work determined by Village Engineer or qualified Village Agent listed in executed Certificate of Substantial Completion.

END OF SECTION

SECTION 01 78 00
CLOSEOUT SUBMITTALS

PART 1 GENERAL

1.01 SECTION INCLUDES

- A. Project Record Documents.
- B. Warranties and bonds.

1.02 RELATED REQUIREMENTS

- A. Section 01 30 00 - Administrative Requirements: Submittals procedures, shop drawings, product data, and samples.
- B. Section 01 31 00 - Sample Performance and Maintenance and Guarantee Bond: Bond duration requirements.
- C. Section 01 70 00 - Execution and Closeout Requirements: Contract closeout procedures.
- D. Section 33 09 00 - Sewer Cleaning and Televising: Electronic media requirements.
- E. Individual Product Sections: Warranties required for specific products or Work.

1.03 REFERENCE STANDARDS

- A. North American Vertical Datum - NAVD88; 1988.
- B. State Plane Coordinate System - MI83-SIF; Latest Edition.

1.04 SUBMITTALS

- A. Project Record Documents: Submit documents to Village Engineer or qualified Village Agent as follows:
 - 1. Record plans showing final locations of all hard surfaces, landscaping and utilities, final grades for hydrants, gate wells, water valves and curb boxes, sanitary and storm sewer pipe, manholes, catch basins, wyes, stubs, clean outs, trace wire boxes, and other appurtenances shall be submitted to Village Engineer or qualified Village Agent for review and approval.
 - a. Locations shall be in State Plane Coordinate System and elevations shall be in North American Vertical Datum.
 - b. Upon acceptance, the Contractor shall provide one (1) set of mylar base prints and two (2) paper copies of the construction drawings to the Owner, signed and sealed by Contractor's Engineer, and marked as-built.
 - 2. Electronic copies of all record plans shall be submitted to the Village Engineer or qualified Village Agent in AutoCAD and PDF format.
 - 3. Sewer videos shall be submitted in accordance with Section 33 09 00.
 - 4. Executed easements and agreements. Record drawings shall include Liber and Page of all easements.
 - 5. Witness drawings for all water, storm, and sanitary leads, stubs, clean-outs, and trace boxes in pdf format.
- B. Warranties and Bonds: Submit documents to Village Engineer or qualified Village Agent with the following modification(s):
 - 1. For items of Work for which acceptance is delayed beyond Date of Substantial Completion, submit within 10 days after acceptance, listing the date of acceptance as the beginning of the warranty period.

2. Submit Warranties and Bonds in final form, two hard copies and one electronic copy in pdf format, prior to submission of the request for final completion.

PART 2 PRODUCTS - NOT USED

PART 3 EXECUTION

3.01 PROJECT RECORD DOCUMENTS

- A. Maintain on Site one set of the following record documents; record actual revisions to the Work:
 1. Drawings.
 2. Approved Change Proposals.
 3. Written Interpretations and Clarifications.
 4. Approved Shop Drawings, product data, and samples.
 5. Manufacturer's instruction for assembly, installation, and adjusting.
- B. Ensure entries are complete and accurate, enabling future reference by Owner.
- C. Store record documents separate from documents used for construction.
- D. Record information concurrent with construction progress.
- E. Record Drawings and Shop Drawings: In addition to requirements of individual specification sections, legibly mark each item to record actual construction including:
 1. Measured depths of foundations in relation to finish first floor datum.
 2. Measured horizontal and vertical locations of underground utilities and appurtenances, referenced to permanent surface improvements.
 3. Details not on original Drawings.

3.02 ASSEMBLY OF OPERATION AND MAINTENANCE MANUALS

- A. Assemble operation and maintenance data into durable manuals for Owner's personnel use, with data arranged in the same sequence as, and identified by, the specification sections.
- B. Where systems involve more than one specification section, provide separate tabbed divider for each system.
- C. Binders: Commercial quality, 8-1/2 by 11 inch three D side ring binders with durable plastic covers; 3 inch maximum ring size. When multiple binders are used, correlate data into related consistent groupings.
- D. Cover: Identify each binder with typed or printed title OPERATION AND MAINTENANCE INSTRUCTIONS; identify title of Project; identify subject matter of contents.
- E. Project Directory: Title and address of Project; names, addresses, and telephone numbers of Village Engineer or qualified Village Agent, Consultants, Contractor and subcontractors, with names of responsible parties.
- F. Tables of Contents: List every item separated by a divider, using the same identification as on the divider tab; where multiple volumes are required, include all volumes Tables of Contents in each volume, with the current volume clearly identified.
- G. Dividers: Provide tabbed dividers for each separate product and system; identify the contents on the divider tab; immediately following the divider tab include a description of product and major component parts of equipment.

- H. Text: Manufacturer's printed data, or typewritten data on 20 pound paper.
- I. Drawings: Provide with reinforced punched binder tab. Bind in with text; fold larger drawings to size of text pages.
- J. Arrangement of Contents: Organize each volume in parts as follows:
 - 1. Project Directory.
 - 2. Table of Contents, of all volumes, and of this volume.
 - 3. Operation and Maintenance Data: Arranged by system, then by product category.
 - a. Source data.
 - b. Product data, shop drawings, and other submittals.
 - c. Operation and maintenance data.
 - d. Field quality control data.
 - e. Photocopies of warranties and bonds.
 - 4. Design Data: To allow for addition of design data furnished by Village Engineer or qualified Village Agent or others, provide a tab labeled "Design Data" and provide a binder large enough to allow for insertion of at least 20 pages of typed text.

3.03 WARRANTIES AND BONDS

- A. Maintain bonds for durations required in Section 01 31 00 Paragraph 15.1.1.
- B. Obtain warranties, executed in duplicate by responsible subcontractors, suppliers, and manufacturers, within 10 days after completion of the applicable item of Work. Except for items put into use with Owner's permission, leave date of beginning of time of warranty until Date of Substantial Completion is determined.
- C. Verify that documents are in proper form, contain full information.
- D. Co-execute submittals when required.
- E. Retain warranties until time specified for submittal.
- F. Manual: Bind in commercial quality 8-1/2 by 11 inch three D side ring binders with durable plastic covers.
- G. Cover: Identify each binder with typed or printed title WARRANTIES AND BONDS, with title of Project; name, address and telephone number of Contractor and equipment supplier; and name of responsible company principal.
- H. Table of Contents: Neatly typed, in the sequence of the Table of Contents of the Project Manual, with each item identified with the number and title of the specification section in which specified, and the name of product or Work item.
- I. Separate each warranty or bond with index tab sheets keyed to the Table of Contents listing. Provide full information, using separate typed sheets as necessary. List Subcontractor, Supplier, and manufacturer, with name, address, and telephone number of responsible principal.

END OF SECTION

SECTION 31 22 00
STRIPPING AND GRADING

PART 1 GENERAL

1.01 SECTION INCLUDES

- A. Rough grading the Site for site structures and building pads.

1.02 RELATED REQUIREMENTS

- A. Section 31 23 16.13 - Trenching: Trenching and backfilling for utilities.
- B. Section 32 92 19 - Restoration: Finish ground cover.

1.03 SUBMITTALS

- A. See Section 01 30 00 - Administrative Requirements, for submittal procedures.
- B. Project Record Documents: Accurately record actual locations of utilities remaining by horizontal dimensions, elevations or inverts, and slope gradients.

PART 2 PRODUCTS

2.01 MATERIALS

- A. Topsoil: See Section 32 92 19.

PART 3 EXECUTION

3.01 PREPARATION

- A. Identify required lines, levels, contours, and datum.
- B. Stake and flag locations of known utilities.
- C. Locate, identify, and protect from damage above- and below-grade utilities to remain.
- D. Install Soil Erosion and Sedimentation Control measures.
- E. Provide temporary means and methods to remove all standing or ponding water from areas prior to grading.
- F. Protect site features to remain, including but not limited to bench marks, survey control points, existing structures, fences, sidewalks, paving, and curbs, from damage by grading equipment and vehicular traffic.
- G. Protect trees to remain by providing substantial fencing around entire tree at the outer tips of its branches; no grading is to be performed inside this line.
- H. Protect plants, lawns, and other features to remain as a portion of final landscaping.

3.02 ROUGH GRADING

- A. Remove subsoil from areas to be further excavated, re-landscaped, or re-graded.
- B. Do not remove wet subsoil, unless it is subsequently processed to obtain optimum moisture content.
- C. When excavating through roots, perform Work by hand and cut roots with sharp axe.

- D. Benching Slopes: Horizontally bench existing slopes greater than 1:4 to key fill material to slope for firm bearing.
- E. Stability: Replace damaged or displaced subsoil to same requirements as for specified fill.
- F. Remove and replace soils deemed unsuitable by classification and which are excessively moist due to lack surface water control.

3.03 SOIL REMOVAL

- A. Stockpile excavated topsoil on Site or legally dispose of off Site.
- B. Stockpile excavated subsoil on Site or legally dispose of off Site.
- C. Stockpiles: Use areas designated on Site; pile depth not to exceed 8 feet unless otherwise approved by Village Engineer or qualified Village Agent; protect from erosion.

3.04 TOLERANCES

- A. Top Surface of Subgrade: Plus or minus 0.10 foot from required elevation.

3.05 REPAIR AND RESTORATION

- A. Existing Facilities, Utilities, and Site Features to Remain: If damaged due to this Work, repair or replace to original condition.
- B. Trees to Remain: If damaged due to this Work, trim broken branches and repair bark wounds; if root damage has occurred, obtain instructions from Village Engineer or qualified Village Agent as to remedy.
- C. Other Existing Vegetation to Remain: If damaged due to this Work, replace with vegetation of equivalent species and size.

3.06 CLEANING

- A. Remove unused stockpiled topsoil and subsoil. Grade stockpile area to prevent standing water.
- B. Leave Site clean and raked, ready to receive landscaping.

END OF SECTION

SECTION 31 23 00

DEWATERING

PART 1 - GENERAL

1.01 DESCRIPTION

- A. Section includes specifications for temporary dewatering systems.

1.02 RELATED REQUIREMENTS

- A. Section 33 09 00 - Sewer Cleaning and Televising.

1.03 SYSTEM DESCRIPTION

- A. Remove water which accumulates in excavations during the progress of Work so that all Work can be done in the dry, unless otherwise approved by the Engineer.
 - 1. Keep excavated areas free from water while underground utilities or structures are constructed, while concrete is setting and until backfill or elements of the structure have been placed to a sufficient height to anchor the Work against possible leakage or buoyant uplift forces.
 - 2. A height to anchor the Work against buoyant uplift forces shall be considered sufficient when the dead load weight of the backfill or elements of the structure exceeds the uplift forces by a minimum factor-of-safety of 1.5.
- B. In addition to the other requirements specified herein, design the dewatering systems to perform as follows:
 - 1. Prevent damage to adjacent properties, buildings, structures, utilities, and other Work as a result of settlement or other groundwater-related effects.
 - 2. At all times, maintain groundwater levels over the entire excavation a minimum of 3 feet below the excavation grade.
- C. At all times, have on Site sufficient pumping equipment for immediate use, including standby pumps for use in case other pumps become inoperable. Dispose of water in accordance with the detailed requirements specified herein and so as to cause no injury to personnel or the public, damage to public or private property, nor menace to the public health.
- D. Design dewatering system to prevent pumping fines from below grade or disturbing materials exposed at the excavation bottom. Wells shall be cased, and filter(s) shall be provided to prevent such pumping of fines.
- E. Provide a sufficient number of monitoring wells to confirm the following:
 - 1. The dewatering system is performing as intended and is achieving the specified reduction in groundwater levels.
 - 2. Site groundwater levels inside and outside dewatered excavations to determine the acceptability of removing the dewatering system from operation.
- F. Furnish filtration system for construction dewatering for the purpose of filtering silt prior to discharge of water.
- G. If the approved methods include displacing groundwater as concrete or other Work is placed in excavations, the dewatering system shall capture groundwater as it is displaced and follow the procedures herein for its containment, analysis, and discharge.

1.04 SUBMITTALS

- A. See Section 01 30 00 - Administrative Requirements, for submittal procedures.
- B. Submit dewatering plan including the following elements:
 - 1. The proposed type of dewatering system.
 - 2. Arrangement, location, and depths of system components.
 - 3. Complete description of equipment and instrumentation to be used, with installation, operation and maintenance procedures.
 - 4. Types and sizes of filters.
 - 5. Design calculations demonstrating adequacy of the proposed system and equipment.
 - 6. Methods of disposal of pumped water.
 - 7. Method of water quality monitoring.
 - 8. Type of filtration and chemical treatment of contaminated water, as applicable.
 - 9. Method for establishing and monitoring Site groundwater levels.
 - 10. Criteria for determining the acceptability of removing the dewatering system from operation.
- C. Prior to removing the dewatering system from operation, submit documentation and calculations verifying that the approved criteria for determining the acceptability of removing the system from operation have been met.

1.05 DELIVERABLES

- A. Submit copies of permits and registrations required for Work of this Section.

1.06 QUALITY ASSURANCE

- A. Design shall be prepared by a person qualified and experienced to perform such design.
- B. Dewatering Contractor Qualifications: Registered by the State of Michigan as required in Part 127, Water Supply and Sewer Systems, of the Public Health Code, Public Act 368 of 1978.

1.07 APPROVALS/REGISTRATIONS

- A. Apply for and secure a Part 327 large water withdrawal permit if the proposed dewatering system will have a pump capacity of 70 gallons per minute or more combined total for all pumps on the property. Utilize the Water Withdrawal Assessment Tool to register the proposed water withdrawal with EGLE prior to commencement of dewatering. This online tool can be found at:

[https://www.egle.state.mi.us/wwat/\(S\(eaz4fowhabbzsgioyit2fsm\)\)/default.aspx](https://www.egle.state.mi.us/wwat/(S(eaz4fowhabbzsgioyit2fsm))/default.aspx)

- B. The Part 327 permit application can be found at:

https://www.michigan.gov/documents/egle/egle-wrd-wateruse-permitapp_658371_7.pdf

PART 2 - PRODUCTS (NOT USED)

PART 3 - EXECUTION

3.01 DEWATERING

- A. Comply with all quality and quantity discharge requirements of the authority having jurisdiction and the Michigan Department of Environmental Quality during discharge operations.
- B. The Contractor will be responsible for furnishing the necessary labor and supervision, pumps, conduits, filters, and other materials/equipment to commission and operate the dewatering system.
- C. Except as otherwise indicated in the Contract Documents, perform dewatering to accomplish a lowering of measured static ground water level to an elevation which is suitable for the construction of utilities and structures below grade.
- D. When pumping is required to reduce groundwater levels, accomplish pumping in a manner that will not disrupt the surrounding environment.
- E. The pumping of ground water shall be discharged to nearby storm sewers or water courses.
 - 1. Extracted groundwater of sufficient quality as shown by test data may be used on Site with Engineer's written approval for those purposes approved by the Engineer.
- F. The Contractor shall not discharge quantities of water in excess of the capacity of existing storm sewers or water courses and he shall be responsible for any damage incurred to storm sewers or water courses which result from his actions.
- G. Storm sewers used for ground water discharge shall be maintained and left in a clean condition in accordance with Section 33 09 00.
- H. Equipment used by the Contractor for temporary pumping of ground water shall be adequately equipped with suitable muffler to reduce the operating noise to a level acceptable to the Engineer.
- I. The use of excessively noisy equipment for night time pumping will not be allowed. The Contractor is encouraged to use electrically driven pumps to eliminate pumping noise.
- J. If any dewatering well pumps fines, terminate pumping and modify well or construct new well to eliminate the pumping of fines.
- K. Do not turn off the dewatering system in a manner that the upsurge in water weakens the subgrade for completed excavation and structure foundation Work.
- L. Remove filters and other dewatering facilities from the Site at the completion of dewatering operations.

END OF SECTION

SECTION 31 23 16.13

TRENCHING

PART 1 GENERAL

1.01 SECTION INCLUDES

1.02 RELATED REQUIREMENTS

- A. Section 31 23 00 - Dewatering.
- B. Section 33 05 13 - Manholes and Structures.
- C. Section 33 08 00 - Sewer Bypass Flow Control.
- D. Section 33 09 01 - Installation and Acceptance Testing of Pipe and Accessories.
- E. Section 33 14 16 - Water Piping.
- F. Section 33 31 13 - Sanitary Sewer Piping.
- G. Section 33 31 23 - Sanitary Force Main Piping.
- H. Section 33 42 11 - Storm Sewer Piping.

1.03 SUBMITTALS

- A. See Section 01 30 00 - Administrative Requirements, for submittal procedures.
- B. Materials Sources: Submit name of imported materials source.

PART 2 PRODUCTS

2.01 FILL MATERIALS

- A. Stone: MDOT 6A washed, crushed stone.
- B. Embedment Material:
 - 1. MDOT Class II granular material.
 - 2. MDOT 6A washed, crushed stone.
- C. Class A Backfill: MDOT Class II granular material.
- D. Class B Backfill: Subsoil excavated on-site.
 - 1. Free of lumps larger than 3 inches, rocks larger than 2 inches, roots, logs, stumps, muck, frozen material, refuse, expansive materials, topsoil, debris, organic, and other deleterious materials.

PART 3 EXECUTION

3.01 UTILITY EXCAVATION:

- A. Work shall include:
 - 1. Furnishing of all labor, materials, and equipment necessary for removals, excavation, trenching or tunneling in earth and in rock, and the complete drainage of excavations.

2. Temporary and permanent sheeting, bracing and shoring of sides of excavations. Open cut excavations for shafts or other structures shall be adequately braced and/or sheeted to prevent caving or squeezing of the soil. Tunnels shall be sheeted and/or braced as necessary to enable the Work to be protected with safety to the men, the Work, and neighboring structures.
 3. Removal of drainage structures, culverts, and sewers in accordance with MDOT Standard Specifications for Construction - Section 203 with the following modification(s):
 - a. Drainage structure abandonment is not allowed unless specifically indicated on the Drawings or as directed by Village Engineer or qualified Village Agent.
 - b. Water main and services shall also be included in the Work.
 4. Disposition of excavated materials during construction and of excess excavated materials after backfilling.
- B. Classification of Excavation:
1. Earth, as a name for excavated material, shall include all glacial deposit, whether cemented or not, except solid boulders one-half cubic yard or more in volume. It shall include all alluvial deposits and material of every kind that can be excavated with equal facility by the equipment and means used for other earth excavation in the Work.
 2. Rock, as a name for excavated material, shall include pre-glacial solid ledge rock that can be removed most practically by blasting, barring, or wedging or by some other standard method of quarrying solid rock; it shall include boulders of one-half cubic yard or more in volume. It shall not include fragile, friable, or disintegrated materials of any kind that can be excavated with equal facility by equipment and means used for earth excavation in this Work.
- C. Method of Excavation:
1. All excavation shall be by open cut from the surface unless otherwise indicated on Drawings.
 2. All excavations for utilities and appurtenances shall be completed in such a manner and to such depth and width as will give ample room for building the structures, compaction of specified backfill around the structure, and for bracing, sheeting and supporting the sides of the excavation for pumping and draining of ground water and sewage which may be encountered, and for the removal from the trench of all materials excavated.
- D. Limits of Excavation in Earth:
1. Excavations for structures shall be extended sufficiently beyond the limits of the structure to provide ample room for form construction and other construction methods to be followed.
 2. Excavation shall be of sufficient width and depth to provide adequate room for construction and installation of the Work to the lines, grades, and dimensions called for on the Drawings, except that the width of a trench from the invert to a height 12 inches above the top of the pipe barrel shall not be greater than 12 inches plus the outside diameter of the pipe barrel, except for piping 4 inches through 15 inches, the width of the trench may be 30 inches.
 - a. If maximum trench width, as specified above, is exceeded, unless otherwise shown on the Drawings, Contractor shall install, at his own expense, such concrete cradling or other bedding as approved by the Village Engineer or qualified Village Agent, to support the added load of the backfill.
 3. Where, through the Contractor's construction procedure, or because of poor existing ground conditions, it is impossible to maintain alignment and grade properly the Contractor shall, at his own expense, excavate below grade and replace with stone in order to ensure that the pipe, when laid, will maintain the correct alignment and grade.
 4. In excavating for utilities the excavation shall at all times be finished to the required grade for an adequate distance in advance of the completed utility. However, unless otherwise permitted by the Village Engineer or qualified Village Agent:

- a. not more than 50 feet of trench shall be open at one time in advance of the utility,
 - b. at no time shall more than 150 lineal feet of trench be opened and incompletely backfilled. The remainder of the area of trenching operations shall be available for safe vehicular and pedestrian traffic at all times, special exceptions may be allowed by the Village Engineer or qualified Village Agent, and
 - c. backfilling shall accompany excavation in such a manner as to avoid large piles of surplus spoil.
5. The length of street which may be occupied by the construction activities at any one time shall be subject to the discretion of the Village Engineer or qualified Village Agent and will be based on the requirements of use of the street by the public. However, unless otherwise permitted by the Village Engineer or qualified Village Agent,
- a. not more than 1,000 consecutive feet of street shall be occupied at one time.
 - b. vehicular traffic through the street shall not be entirely stopped.
6. Excavated materials shall be temporarily stored along the trench in a manner that will not cause damage to trees, shrubs, fences or other property nor that will endanger the bank of a trench by imposing too great a load thereon.
- E. Disposal of Water and Sewage:
- 1. All methods and procedures for soil erosion and sediment control must meet the Authority Having Jurisdiction and the Michigan Department of Environmental Quality standards for construction.
 - 2. The Contractor shall remove by pumping, bailing, or other acceptable method all water which may accumulate or be found in the trenches and other excavations and shall take all necessary precautions to keep the trenches and other excavations entirely clear of water while the utilities are being constructed.
 - 3. Where existing sewers or drains are encountered during construction, the Contractor shall make adequate provision for diverting the flow of the existing sewers or drains, so as to keep the Work entirely dry during construction.
 - 4. Newly placed concrete shall be adequately protected from damage resulting from ground water or sewage, or from the handling or disposal of water and sewage.
 - 5. Existing house sanitary and storm service leads encountered in the excavation shall be temporarily reconnected to the existing sewer until the new sewer has been completely tested and approved. No connections to new sewers will be allowed until tested and approved.
 - 6. The Contractor shall at all times have sufficient pumping equipment ready for immediate use to carry out the Work.
 - 7. If wet areas of construction are encountered, the Contractor shall make use of well pointing equipment and of other measures such as stone which, in the judgment of the Village Engineer or qualified Village Agent are required for laying the utility under dry conditions and with proper bedding of the pipe.
 - 8. Refer to Sections 31 23 00 and 33 08 00 for additional Contractor responsibilities.
- F. Bracing and Sheeting:
- 1. The Contractor shall furnish, install, and maintain such sheeting, bracing, and shoring, as may be required to properly support the sides of any excavation and to prevent any movement of earth which could in any way injure the Work.
 - 2. If the Village Engineer or qualified Village Agent is of the opinion that, at any point, sufficient and proper supports have not been provided, he may order additional supports at the expense of the Contractor; but neither the placing of such additional supports by the order of the Village Engineer or qualified Village Agent nor the failure of the Village Engineer or qualified Village Agent to order such additional supports placed, shall

release the Contractor from his responsibility for the sufficiency of such supports and the integrity of the Work and protection of existing adjacent property or structures from damages.

3. In the removing of sheeting and bracing after the utility has been constructed, special care shall be taken to prevent any caving of the sides of excavation and injury to the completed Work or to adjacent property.

3.02 PREPARATION FOR UTILITY PLACEMENT

- A. Cut out soft areas of subgrade not capable of compaction in place.
- B. Compact subgrade to density equal to or greater than requirements for subsequent fill material.
- C. Until ready to backfill, maintain excavations and prevent loose soil from falling into excavation.
- D. The foundations in the trench shall be formed to prevent any subsequent settlement and resulting excessive pressure to the pipe after backfilling. If the subgrade is of unstable soil, well pointing or the use of stone will be required to assure that settlement is eliminated. The subgrade shall be carefully formed so that the pipe rests on the correct line and grade. The Contractor may provide the required grade, by:
 1. excavating to a level 4 inches or more below the final grade line and refilling with compacted embedment material to the finish grade. This procedure may be used in stable soils, but is not applicable to unstable soils,
 2. excavating to a level 4 inches or more below the final grade line and refilling with stone to the finish grade. When stone is used to stabilize the trench bottom and/or for dewatering purposes, the stone shall be placed to a point 12 inches over the installed pipe, and shall be the embedment material

3.03 LAYING PIPE

- A. Perform Work in accordance with Section 33 09 01.

3.04 BACKFILLING

- A. After the pipe has been properly positioned for grade and horizontal alignment the trench shall be filled with structural fill equally on both sides of the pipe from the subgrade to a level at least 12 inches above the top of the pipe maintaining pipe alignment.
 1. The embedment material shall be compacted to 95% of maximum dry density.
 2. Backfill for the remaining unfilled portion of the trench shall be in accordance with the Drawings and/or Specifications.
- B. Trenches with backfill for the remaining unfilled portion of the trench shall be in accordance with the Drawings and/or Specifications. Backfill within the 1:1 influence of road surfaces, pavement, sidewalks, curb, driveways, shall be full depth Class A backfill.
- C. Backfill shall be placed over utilities to within 1 foot of final grade prior to acceptance testing.
- D. Class A Backfill:
 1. Backfilling under this designation shall consist of furnishing and placing material from 12 inches above the top of the pipe to the top of the trench in 12 inch layers, compacted to 95% maximum dry density for the entire depth of the trench.
- E. Class B Backfill:
 1. Backfilling under this designation shall consist of backfilling the trench from 12 inches above the top of the pipe to the top of the trench, with selected material excavated from the trench, by ramping the backfill down the trench in layers not exceeding 24 inches in depth and compacting with appropriate equipment.

2. Where trenches are too narrow in width to provide access by heavy equipment, other methods and equipment shall be used to achieve the required degree of compaction.
 3. Materials not meeting Class B Backfill requirements which may be encountered in excavation shall be hauled and disposed of and the Contractor shall furnish sufficient approved material to complete the backfill as required.
 4. Surplus excavated material shall be hauled and disposed of in accordance with the Drawings and/or Specifications.
 5. Granular material which is encountered in the excavated material may be used for the required embedment and/or backfill if approved by the Village Engineer or qualified Village Agent. The use of such material shall not be allowed without prior approval of the Village Engineer or qualified Village Agent.
- F. Any depression resulting from settlement of the trench backfill shall be brought to the proper grade and the surface made to match the adjacent surface.
- G. As soon as practicable after concrete structures have been set, forms and debris have been removed, the surface of the concrete pointed up, the structures have been inspected and approved, the excavated area around structures shall be backfilled up to the specified grade.
- H. Backfill shall not be placed around and over the top of cast-in-place concrete structures until the concrete has attained sufficient strength to sustain all the loads imposed by the backfilling operations.
- I. The Contractor shall maintain all road and driveway crossings in suitable repair.
1. Settlements shall be promptly repaired at all times.
- J. Trenches to be constructed in established lawn areas shall be compacted so as to permit restoration shortly after completion of the backfilling without appreciable settlement.
- K. Maintenance and Restoration of Pavement, Walks, Road Surfaces, Etc.:
1. All concrete or asphalt pavement, curbs, drives and sidewalks removed, destroyed, or damaged by the Contractor shall be replaced by the Contractor in a manner equal or superior to the previously existing pavement. A saw shall be used to make a full depth cut at the nearest control joint on each side of the area to be removed. Green epoxy coated reinforcing bars meeting current MDOT Specifications shall be drilled into the existing concrete curb and driveways where required by the Village Engineer or qualified Village Agent before the replacement concrete is poured.
 2. Where trenches cut or damage roadways or drives other than hard surface pavements, Contractor shall thoroughly compact the trench backfill and restore roadway with an aggregate base at least 8 inches thick and shall, during the life of the contract, maintain the roadway in good condition with additional aggregate as settling takes place.

3.05 FIELD QUALITY CONTROL

- A. See Section 01 40 00 - Quality Requirements, for general requirements for field inspection and testing.
- B. Evaluate results in relation to compaction curve determined by testing uncompacted material in accordance with ASTM D1557 ("modified Proctor").
- C. If tests indicate Work does not meet specified requirements, remove work, replace and retest.
- D. Frequency of Tests: As directed by Engineer.

3.06 CLEANING

- A. Leave unused materials in a neat, compact stockpile.

- B. Remove unused stockpiled materials, leave area in a clean and neat condition. Grade stockpile area to prevent standing surface water.

END OF SECTION

SECTION 32 31 13

GALVANIZED CHAIN LINK FENCE AND GATES

PART 1 GENERAL

1.01 SUMMARY

- A. This Section includes industrial/commercial chain link fence and gates specifications:
 - 1. Galvanized steel coated chain link fabric
 - 2. Galvanized steel framework and fittings
 - 3. Gates: swing and cantilever slide
 - 4. Barbed wire
 - 5. Installation

1.02 REFERENCE STANDARDS

- A. ASTM A121 - Standard Specification for Metallic-Coated Carbon Steel Barbed Wire; 2013.
- B. ASTM A392 - Standard Specification for Zinc-Coated Steel Chain-Link Fence Fabric; 2011a.
- C. ASTM A780/A780M - Standard Practice for Repair of Damaged and Uncoated Areas of Hot-Dip Galvanized Coatings; 2009 (Reapproved 2015).
- D. ASTM A824 - 01 - Standard Specification for Metallic-Coated Steel Marcellled Tension Wire for Use With Chain Link Fence; 2017.
- E. ASTM F1083 - Standard Specification for Pipe, Steel, Hot-Dipped Zinc-Coated (Galvanized) Welded, for Fence Structures; 2013.
- F. ASTM F1184 - Standard Specification for Industrial and Commercial Horizontal Slide Gates; 2016.
- G. ASTM F567 - Standard Practice for Installation of Chain-Link Fence; 2014a.
- H. UL 325 - Standard for Door, Drapery, Gate, Louver, and Window Operators and Systems; Current Edition, Including All Revisions.
- I. ASTM F2200 - Standard Specification for Automated Vehicular Gate Construction; 2014.
- J. ASTM F626 - Standard Specification for Fence Fittings; 2014.
- K. ASTM F900-11 - Standard Specification for Industrial and Commercial Steel Swing Gates; 2017.

1.03 SUBMITTALS

- A. See Section 01 30 00 - Administrative Requirements, for submittal procedures.
- B. Shop drawings: Site plan showing layout of fence location with dimensions, location of gates and opening size, cleared area, elevation of fence, gates, footings and details of attachments.

PART 2 - PRODUCTS

2.01 MANUFACTURERS

- A. Framework, posts, rails, fabric, and fittings for chain link fence and gate system:

Technical Standards For Design
and Construction

32 31 13 - 1

GALVANIZED CHAIN LINK
FENCE AND GATES

1. Merchants Metals: www.merchantsmetals.com. 830 Grand Oaks Drive, Howell, MI 48843. Phone 810.227.3036.
2. Substitutions: See Section 01 60 00 - Product Requirements.

2.02 CHAIN LINK FABRIC

- A. Steel Chain Link Fabric:
1. Height as indicated on Drawings.
 2. Zinc-Coated Steel Fabric: ASTM A392 hot dipped galvanized after weaving (GAW).
 - a. Class 2 - 2.0 oz/ft² (610 g/m²) - 9 gauge, 2 inch mesh.
 3. Fabric selvage:
 - a. Standard fabric selvage for 2 inch mesh 72 inch high and higher is knuckle finish at one end, twist at the other, K&T.
 - b. Fabric less than 72 inch, knuckle finish top and bottom, K&K.

2.03 ROUND STEEL PIPE FENCE FRAMEWORK

- A. Round steel pipe and rail:
1. Schedule 40 standard weight pipe, in accordance with ASTM F1083, 1.8 oz/ ft² hot dip galvanized zinc exterior and 1.8 oz/ft² hot dip galvanized zinc interior coating.
 2. High Strength Grade: Minimum yield strength 50,000 psi (344 MPa)
 3. Line Posts: 2.375 inch OD @ 3.65 lb/ft.
 4. End, Corner, Pull Post: 2.875 inch OD @ 5.79 lb/ft.
 5. Top, Brace, Bottom and Intermediate Rails: 1.660 inch OD @ 2.27 lb/ft.

2.04 TENSION WIRE

- A. Metallic Coated Steel Marcellled Tension Wire:
1. 7 gauge core (0.177 in.) marcellled wire complying with ASTM A824 - 01.
 2. Match coating type to that of the chain link fabric.
 3. Type II Zinc-Coated, ASTM A817 Class 5 - 2.0 oz/ft² (610 g/m²)

2.05 BARBED WIRE

- A. Metallic Coated Steel Barbed Wire:
1. Comply with ASTM A121, Design Number 12-4-5-14R, double 12-½ gauge (0.099 in.) twisted strand wire, with 4 point 14 gauge (0.080 in.) round barbs spaced 5 inches on center.
 2. Match coating type to that of the chain link fabric.
 3. Coating Type Z - Zinc-coated: Strand wire coating Type Z, Class 3, 0.80 oz/ft², barb coating 0.70 oz/ft².

2.06 FITTINGS

- A. Tension and Brace Bands:

1. Galvanized pressed steel complying with ASTM F626, minimum steel thickness of 12 gauge (0.105 in.), minimum width of 3/4 in. and minimum zinc coating of 1.20 oz/ft².
 2. Secure bands with 5/16 in. galvanized steel carriage bolts.
- B. Terminal Post Caps, Line Post Loop Tops, Rail and Brace Ends, Boulevard Clamps, Rail Sleeves:
1. In compliance with ASTM F626, pressed steel galvanized after fabrication having a minimum zinc coating of 1.20 oz/ft².
- C. Truss Rod Assembly:
1. In compliance with ASTM F626, 3/8 in. or 5/16" diameter steel truss rod with a pressed steel tightener, minimum zinc coating of 1.2 oz/ft², assembly capable of withstanding a tension of 2,000 lbs.
- D. Tension Bars:
1. In compliance with ASTM F626. Galvanized steel one-piece length 2 in. less than the fabric height.
 2. Minimum zinc coating 1.2 oz./ft².
 3. Bars for 2 in. and 1 3/4 in. mesh shall have a minimum cross section of 3/16 in. by 3/4 in.
 4. Bars for 1 in. mesh shall have a cross section of 1/4 in. by 3/8 in.
 5. Small mesh 3/8 in., 1/2 in. and 5/8 in. shall be attached (sandwiched) to the terminal post using a galvanized steel strap having a minimum cross section of 2 in. by 3/16 in. with holes spaced 15 in. on center to accommodate 5/16 in. carriage bolts which are to be bolted thru the strap the mesh and thru the terminal post.
- E. Barbed Wire Arms:
1. In compliance with ASTM F626, pressed steel galvanized after fabrication, minimum zinc coating of 1.20 oz./ft², capable of supporting a vertical 250 lb load.
 2. Type I - three strand 45 degree (0.785 rad) arm

2.07 TIE WIRE AND HOG RINGS

- A. Basic commercial / industrial applications - 9 gauge core aluminum alloy ties and hog rings in compliance with ASTM F626.

2.08 SWING GATES

- A. Galvanized steel pipe welded fabrication in compliance with ASTM F900-11.
- B. Gate frame members 1.900 in. OD, ASTM F 1083 schedule 40 galvanized steel pipe
- C. Frame members spaced no greater than 8 ft. apart vertically and horizontally.
- D. Welded joints protected by applying zinc-rich paint in accordance with ASTM A780/A780M.
- E. Positive locking gate latch, pressed steel galvanized after fabrication.
- F. Galvanized malleable iron or heavy gauge pressed steel post and frame hinges.
- G. Provide lockable drop bar and gate holdbacks with double gates.
- H. Gate Post: 4.000 inch OD @ 9.11 lb/ft, regular grade in accordance with ASTM F1083.
 1. Match gate fabric to that of the fence system.

2.09 HORIZONTAL SLIDE GATES

A. Cantilever Slide Gates:

1. Made in accordance with ASTM F1184 Type I, Class 2, and in compliance with UL 325, and ASTM F2200.
2. Gate to be made of Aluminum Alloy 6005A-T61.
3. All square members are 2" sq. weighing 0.94 lb/ft.
4. Complete frame welded to top one piece track and 4" x 2" bottom rail weighing 1.71 lbs./ft.
5. Supply 2 truck assemblies that are swivel type having lubricated and scaled ball bearing wheels that will align in the track during all normal operations of the gate.

Standard Opening	Standard Support Overhang
11'-0" through 14'-0"	7'-6"
15'-0" through 22'-0"	10'-0"
23'-0" through 30'-0"	12'-0"
31'-0" through 40'-0"	16'-0"

Gates 31'0" (9449 mm) through 40'0" (12192 mm) dual top tracks and two additional truck assemblies. For gates over 40'0" (12192 mm), contact Merchants Metals for custom drawings and specs.

- ### B. Chain Link 2" Fabric: Galvanized After Weaving (GAW).
- C. Finish: Natural Aluminum or Polymer coated horizontal slide gates and posts shall match the coating type and color as that specified for the fence framework, available colors - black, green, or brown.
- D. Gateposts, 4" O.D. schedule 40 weighing 9.11 lb/ft. Single gates with single tracks require 3 gate posts. (1 latch post and 2 support posts) Single gates with dual tracks require 5 gate posts. (1 latch and 2 dual support posts) Double gates require twice the number of support posts but do not have a latch post.
- E. Electrically operated horizontal slide gates must be manufactured and installed to comply with the safety requirements of ASTM F2200 and UL 325.

2.10 CONCRETE

- ### A. Concrete for post footings shall be MDOT Type S3.

PART 3 EXECUTION

3.01 FRAMEWORK INSTALLATION

A. Posts:

1. Posts shall be set plumb in concrete footings in accordance with ASTM F567.
2. Minimum footing depth, 42 in. plus an additional 3 in. depth for each 1 ft. increase in the fence height over 4 ft.
3. Minimum footing diameter 6 times the largest cross section of the post up to a 4.00" dimension and 4 times the largest cross section of post greater than a 4.00" dimension.
4. Top of concrete footing to be at grade crowned to shed water away from the post.
5. Line posts installed at intervals not exceeding 10 ft. on center.

B. Top rail:

1. When specified, install 21 ft. lengths of rail continuous through the line post or barb arm loop top.
 2. Splice rail using top rail sleeves minimum 6 in. long.
 3. Rail shall be secured to the terminal post by a brace band and rail end.
 4. Bottom rail or intermediate rail shall be field cut and secured to the line posts using boulevard clamps or brace band with rail end.
 5. Fences 12 feet high or higher require mid rail.
- C. Terminal posts:
1. End, corner, pull and gate posts shall be braced and trussed for fence 6 ft. and higher and for fences 5 ft. in height not having a top rail.
 2. The horizontal brace rail and diagonal truss rod shall be installed in accordance with ASTM F567.
- D. Tension wire:
1. Shall be installed 4 in. up from the bottom of the fabric.
 2. Fences without top rail shall have a tension wire installed 4 in. down from the top of the fabric.
 3. Tension wire to be stretched taut, independently and prior to the fabric, between the terminal posts and secured to the terminal post using a brace band.
 4. Secure the tension wire to each line post with a tie wire. Install the top tension wire through the barb arm loop for fences having barbed wire and no top rail.

3.02 CHAIN LINK FABRIC INSTALLATION

- A. Chain Link Fabric:
1. Install fabric to outside of the framework maintaining a ground clearance of no more than 2 inches.
 2. Attach fabric to the terminal post by threading the tension bar through the fabric; secure the tension bar to the terminal post with tension bands and 5/16 in. carriage bolts spaced no greater than 12 inches on center.
 3. Small mesh fabric less than 1 in., attach to terminal post by sandwiching the mesh between the post and a vertical 2 in. wide by 3/16 in. galvanized steel strap using carriage bolts, bolted thru the bar, mesh and post spaced 15 in. on center.
 4. Chain link fabric to be stretched taut free of sag.
 5. Fabric to be secured to the line post with tie wires spaced no greater than 12 inches on center and to horizontal rail spaced no greater than 18 inches on center.
 6. Aluminum alloy tie wire shall be installed following ASTM F567: Wrap the tie around the post or rail and attached to a fabric wire picket on each side of the post or rail by twisting the tie wire around the fabric wire picket two full turns, cut off excess wire and bend over to prevent injury.
 7. Preformed 9 gauge power-fastened wire ties shall be installed following ASTM F626: Wrap the tie a full 360° around the post or rail and fabric wire picket, using a variable speed drill, twist the two ends together three full turns, cut off any excess wire and bend over to prevent injury.
 8. Secure the fabric to the tension wire by crimping hogs rings around a fabric wire picket and tension wire.

3.03 BARBED WIRE INSTALLATION

- A. Barbed Wire:

1. Stretched taut between terminal posts and secured in the slots provided on the line post barb arms.
2. Attach each strand of barbed wire to the terminal post using a brace band.
 - a. Type I - three strand 45 degree (0.785 rad) arm facing outward.

3.04 GATE INSTALLATION

A. Horizontal Slide Gates:

1. Install according to manufacturer's instructions and in accordance with ASTM F567.
2. Gates shall be plum in the closed position, installed to slide with an initial pull force no greater than 40 lbs.
3. Double gate drop bar receivers to be installed in a concrete footing as required by site conditions and codes. Ground clearance shall be 3 in. (76 mm), grade permitting.

3.05 NUTS AND BOLTS

A. Bolts:

1. Carriage bolts used for fittings shall be installed with the head on the secure side of the fence.
2. All bolts shall be peened over to prevent removal of the nut.

3.06 CLEAN UP

- #### **A. The area of the fence line shall be left neat and free of any debris caused by the installation of the fence.**

END OF SECTION

SECTION 32 92 19
RESTORATION

PART 1 GENERAL

1.01 SECTION INCLUDES

- A. Placing topsoil.
- B. Seeding, mulching and fertilizer.
- C. Maintenance.

1.02 REFERENCE STANDARDS

- A. MDOT Standard Specifications for Construction - Section 816 - Turf Establishment; 2012.
- B. MDOT Standard Specifications for Construction - Section 817 - Landscape Mowing; 2012.
- C. MDOT Standard Specifications for Construction - Section 917 - Turf and Landscaping Materials; 2012.

1.03 SUBMITTALS

- A. See Section 01 30 00 - Administrative Requirements, for submittal procedures.
- B. Topsoil samples.
- C. Material Certifications for seed, fertilizer and mulch.

1.04 DELIVERY, STORAGE, AND HANDLING

- A. Deliver fertilizer in waterproof bags showing weight, chemical analysis, and name of manufacturer.

PART 2 PRODUCTS

2.01 MATERIALS

- A. Contractor shall furnish turf and landscaping materials in accordance with MDOT Standard Specifications for Construction - Section 917 with the following modification(s):
 - 1. Straw mulch blankets shall be single net with rapid degrading photodegradable plastic netting.

PART 3 EXECUTION

3.01 EXAMINATION

- A. Verify that prepared soil base is ready to receive the Work of this Section.

3.02 PREPARATION

- A. Prepare subgrade in accordance with Section 31 22 00.

3.03 TURF ESTABLISHMENT

- A. The Contractor shall establish turf in accordance with MDOT Standard Specifications for Construction - Section 816 with the following modification(s):

1. Contractor shall be responsible for watering and cultivating required to establish turf in a timely period.
2. All topsoil, salvaged or imported, shall be screened and free of rocks or other debris and contaminants prior to placement.
3. All restoration areas shall receive Class A fertilizer, evenly applied at 228 pounds per acre on a prepared seed bed.
4. Apply straw mulch to a uniform thickness with an application rate of 2 ton per acre (+/-3 inches).
5. Use mulch blankets on all slopes greater than 1:5 but less than 1:2.

3.04 LANDSCAPE MOWING

- A. The Contractor shall perform landscape mowing in accordance with MDOT Standard Specifications for Construction - Section 817 with the following modification(s):
 1. Contractor shall perform the first mowing after turf establishment at a time approved by the Village Engineer or qualified Village Agent.
 2. Contractor shall rake and remove any rocks and dirt clods with a diameter greater than 2 inches and remove other litter exposed after mowing.

3.05 RESTORATION

- A. Prior to final acceptance of the Work, the Contractor shall:
 1. Remove all excess excavation, stockpiles and debris from the Site.
 2. Neatly fill and fine grade all exposed construction areas.
 3. Sweep clean all sidewalks, pavements, and driveways.
 4. Restore as nearly as practical, all lawns, trees and shrubbery to their original condition and to the satisfaction of the Village Engineer or qualified Village Agent.

END OF SECTION

SECTION 33 05 13
MANHOLES AND STRUCTURES

PART 1 GENERAL

1.01 SECTION INCLUDES

- A. Modular precast concrete structures including; manhole, catch basin, and wetwell sections with tongue-and-groove joints, covers, anchorage, and accessories.

1.02 RELATED REQUIREMENTS

- A. Section 31 23 16.13 - Trenching: Embedment material.

1.03 REFERENCE STANDARDS

- A. ASTM C1244 - Standard Test Method for Concrete Sewer Manholes by the Negative Air Pressure (Vacuum) Test Prior to Backfill; 2011.
- B. ASTM C1821 / C1821M - Standard Practice for Installation of Underground Circular Precast Concrete Manhole Structures; 2016.
- C. MDOT Standard Specifications for Construction - Section 403 - Drainage Structures; 2012.
- D. ASTM C478 - Standard Specification for Circular Precast Reinforced Concrete Manhole Sections; 2015a.
- E. ASTM C923 - Standard Specification for Resilient Connectors Between Reinforced Concrete Manhole Structures, Pipes, and Laterals; 2008 (Reapproved 2013).

1.04 SUBMITTALS

- A. See Section 01 30 00 - Administrative Requirements, for submittal procedures.
- B. Shop Drawings: Indicate structure locations, elevations, piping sizes and elevations of penetrations.

1.05 QUALITY ASSURANCE

- A. Manufacturer Qualifications: Company specializing in manufacturing products specified in this section with minimum 3 years documented experience.

1.06 FIELD CONDITIONS

- A. Maintain materials and surrounding air temperature to minimum 50 degrees F prior to, during, and 48 hours after completion of concrete, mortar, and grout placement.

PART 2 PRODUCTS

2.01 MATERIALS

- A. Structure Sections: Reinforced precast concrete in accordance with ASTM C478, with resilient connectors complying with ASTM C923.
- B. Mortar: Type S.
- C. Grout: Fine, non-shrink.

2.02 COMPONENTS

- A. Lid and Frame: As indicated on Drawings.
- B. Flexible Rubber Connectors: All penetrations shall be fitted with a flexible boot.
 - 1. Manufacturers:
 - a. Trelleborg; Kor-N-Seal I 106-406:
www.trelleborg.com/en/pipe-seals/products--and--solutions/connector--sealing--systems/pipe-to-manhole/kor--n-seal--i--106_406--series--pipe-to-manhole--connector.
 - b. Substitutions: See Section 01 60 00 - Product Requirements.
- C. Structure Steps: Steps shall be reinforced polypropylene plastic.
 - 1. Manufacturers:
 - a. M.A. Industries, Inc.; PS2-PFS; www.precast-supplies.com/products/ps2-pfs.
 - b. Substitutions: See Section 01 60 00 - Product Requirements.
- D. Concrete Adjustment Rings:
 - 1. Manufacturers:
 - 2. Northern Concrete Pipe; Concrete Adjustment Ring: www.ncp-inc.com.
 - 3. Substitutions: See Section 01 60 00 - Product Requirements.
- E. Water Infiltration Sealing System:
 - 1. Manufacturers:
 - 2. GPT Industries; Boa-Tape:
<https://www.gptindustries.com/en/products/boa-tape-extra-grip-infiltration-taping-seal-system>.
 - 3. Substitutions: See Section 01 60 00 - Product Requirements.

2.03 CONFIGURATION

- A. Clear Inside Dimensions: As indicated on Drawings.
- B. Design Depth: As indicated on Drawings.
- C. Clear Lid Opening: As indicated on Drawings.
- D. Pipe Entry: Provide openings as indicated on Drawings.
- E. Steps: 13 inches wide, 16 inches on center vertically, set into structure wall or as required by code. Bottom step max 24 inches above floor. Steps shall be factory installed.
- F. All flow channels/benches shall be factory installed unless otherwise indicated on Drawings.
- G. All catch basins shall include a sump as indicated in Section 01 80 31 - Storm Catch Basins.
- H. All bottom riser sections shall have the base slab poured monolithically with the riser unless otherwise indicated on Drawings.
- I. Top Sections (unless otherwise indicated on Drawings):
 - 1. Manholes: Cone section unless otherwise approved by Engineer.

- a. Greenbelt Applications
 - 1) Concrete adjustment rings secured to precast top section with 2 rows of 1/2 inch minimum butyl rope between each adjustment ring.
 - 2) Frame bolted to top section with (4) 5/8 inch dia galvanized threaded stud bolts with washers and nuts.
 - 3) Structure encapsulated in a water infiltration sealing system from 6 inches below top of cone section to top of casting in accordance with manufacturers recommendations.
 - 4) Interior surface grouted and brushed to a smooth finish.
 - b. Pavement Applications
 - 1) Concrete adjustment rings secured to precast top section with 2 rows of 1/2 inch minimum butyl rope between each adjustment ring.
 - 2) Structure encapsulated in a water infiltration sealing system from 6 inches below top of cone section to top of casting in accordance with manufacturers recommendations.
 - 3) Interior surface grouted and brushed to a smooth finish.
2. Catch Basins and Valve Vaults: Cone or Flat top, Interior height on valve vaults shall be 6.5 feet minimum excluding cone section.
- a. Greenbelt Applications
 - 1) Concrete adjustment rings secured to precast top section with 2 rows of 1/2 inch minimum butyl rope between each adjustment ring.
 - 2) Frame bolted to top section with (4) 5/8 inch dia galvanized threaded stud bolts with washers and nuts.
 - 3) Provide 18 inches minimum of cover over flat top.
 - 4) Structure encapsulated in a water infiltration sealing system from 6 inches below top of cone section to top of casting or from bottom of lowest adjustment ring on flat top to top of casting in accordance with manufacturers recommendations.
 - 5) Interior surface grouted and brushed to a smooth finish.
 - b. Pavement Applications
 - 1) Concrete adjustment rings secured to precast top section with 2 rows of 1/2 inch minimum butyl rope between each adjustment ring.
 - 2) Structure encapsulated in a water infiltration sealing system from 6 inches below top of cone section to top of casting or from bottom of lowest adjustment ring on flat top to top of casting in accordance with manufacturers recommendations.
 - 3) Interior surface grouted and brushed to a smooth finish.
 - c. Curb Applications
 - 1) Concrete adjustment rings secured to precast top section with 2 rows of 1/2 inch minimum butyl rope between each adjustment ring.
 - 2) Structure encapsulated in a water infiltration sealing system from 6 inches below top of cone section to top of casting or from bottom of lowest adjustment ring on flat top to top of casting in accordance with manufacturers recommendations.
 - 3) Interior surface grouted and brushed to a smooth finish.
3. Wet Wells: As indicated on Drawings.
- J. Precast joints shall be modified grooved tongue with rubber gaskets.

- K. Sanitary sewer manholes shall include a 1/2 inch galvanized or stainless steel capped pipe nipple approximately 10 inches long precast into manhole at a location 6 inches above the invert of the flow channel to determine groundwater level for testing purposes.
- L. Drop connections shall be a precast exterior drop integral to the structure. Pipe for drop shall be SDR-26 PVC. The precast exterior drop shall include a flexible connection on the upper penetration. Inside drops may be approved by the Village Engineer or qualified Village Agent under special circumstances only.
- M. All joints around pipes entering or leaving structures shall be fitted with flexible rubber connectors.
- N. All openings for pipe shall be fabricated at the time of manufacture, and no structures will be accepted where openings have been made in precast units at the Site unless approved by Village Engineer or qualified Village Agent.
- O. Concrete adjustment rings shall be a minimum of 2 inches thick, reinforced, and include four equally spaced 3/4" diameter holes for bolt down type castings. Cracked or otherwise damaged adjustment rings will be rejected

PART 3 EXECUTION

3.01 INSTALLATION

- A. General:
 - 1. Install structures in accordance with ASTM C1821 / C1821M and MDOT Standard Specifications for Construction - Section 403.
 - 2. Structures shall at all times be constructed under dry conditions with dewatering as required.
 - 3. Contractor shall construct structures in such a manner as to exclude all ground water.
 - 4. No settlement or shearing of the connecting pipe will be allowed.
 - 5. Contractor shall ensure that all pipes are installed at a level equal to or higher than the invert of any flow channels to allow unobstructed flow.
 - 6. Pockets manufactured for pipe penetrations shall be grouted with non-shrink grout to eliminate any voids between the pipe and the flow channel.
- B. Flow Channels (where field fabricated channels are required):
 - 1. For existing structures that require construction of a flow channel, Contractor shall install a flow through test balls with piping to accommodate existing flow while constructing a smooth flow channel approved by Village Engineer or qualified Village Agent.
 - 2. Flow channels shall be constructed in such a manner as to ensure flow through them without splashing on sides or deposition of solids.
 - 3. Concrete floors and flow channels for structures shall be poured under dry conditions and concrete shall be protected for a period of at least 24 hours after placement.
 - 4. The Village Engineer or qualified Village Agent will require poorly constructed flow lines to be rebuilt as required.
 - 5. All concrete surfaces inside structures shall be screeded and floated to a smooth, uniform surface and troweled to a hard finish.
 - 6. Channels shall be constructed of split PVC pipe or wyes securely anchored to the structure floor with stainless steel fasteners or shall be constructed by forming the concrete structure floor to flow channels of the same shape and dimensions as the required split pipe and wyes.

C. Final Adjustment and Finishing:

1. Final grade adjustments shall be made with precast concrete grade adjustment rings.
2. Adjustment rings shall be kept to a minimum by using the thickest rings available for any given application.
3. Set cover frames and covers to match adjacent slope for hard surface applications.

3.02 FIELD QUALITY CONTROL

- A. A test of structures for leakage employing one of the following methods may be required by the Engineer if watertightness is in question.
1. Test structures in accordance with ASTM C1244.
 2. Install plugs on all pipes penetrating the structure, and filling the structures with water to the top. Four hours shall be allowed for absorption before testing is initiated. Allowable exfiltration for 48 inch diameter structures shall be 2 gallons per foot of depth per day. Allowable exfiltration for other diameters shall be as required by the Village Engineer or qualified Village Agent.

END OF SECTION

SECTION 33 06 00
TRACE WIRE AND LOCATOR TAPE

PART 1 GENERAL

1.01 SECTION INCLUDES

- A. Trace wire on all buried:
 - 1. Sanitary mains and service leads.
 - 2. Water mains and service leads.
- B. Detectable Locator Tape on all buried:
 - 1. Sanitary mains and service leads.
 - 2. Water mains and service leads.

1.02 RELATED REQUIREMENTS

- A. Section 33 14 16 - Water Piping.
- B. Section 33 31 13 - Sanitary Sewer Piping.
- C. Section 33 31 23 - Sanitary Force Main Piping.

1.03 REFERENCE STANDARDS

- A. APWA UCC - American Public Works Association - Uniform Color Code for Marking Underground Facilities; 1999.

1.04 SUBMITTALS

- A. See Section 01 30 00 - Administrative Requirements, for submittal procedures.
- B. Product Data: Provide trace wire, trace box, wire connectors and grounding materials.
- C. Project Record Documents
 - 1. Accurately record actual locations of grounding anodes, trace wire routing, connectors, and trace boxes.
- D. Manufacturer's Qualification Statement.

PART 2 PRODUCTS

2.01 GENERAL

- A. All trace wire and trace wire products shall be domestically manufactured in the U.S.A.
- B. Trace Wire:
 - 1. Open Cut:
 - a. Trace wire shall be #12AWG Copper Clad Steel, High Strength with minimum 450 lb. break load, with minimum 30 mil HDPE insulation thickness.
 - b. Manufacturers:
 - 1) Copperhead Industries, LLC; Superflex 1230-HS or heavier as required for application:
www.copperheadwire.com

- 2) Pro-Line Safety Products Company; Pro-Trace 12 SOL HS-CCS: <http://www.prolinesafety.com>.
 - 3) Substitutions: See Section 01 60 00 - Product Requirements.
2. Directional Drilling:
- a. Trace wire shall be #12 AWG Copper Clad Steel, Extra High Strength with minimum 1,150 lb. break load, with minimum 45 mil HDPE insulation thickness.
 - b. Manufacturers:
 - 1) Copperhead Industries, LLC; Soloshot 1245-EHS or heavier as required for application: www.copperheadwire.com/.
 - 2) Pro-Line Safety Products Company; Pro-Trace 12 SOL HDD-CCS: <http://www.prolinesafety.com>.
 - 3) Substitutions: See Section 01 60 00 - Product Requirements.
3. Pipe Bursting/Slip Lining:
- a. Trace wire shall be 7 x 7 Stranded Copper Clad Steel, Extreme Strength with 4,700 lb. break load, with minimum 50 ml HDPE insulation thickness.
 - b. Manufacturers:
 - 1) Copperhead Industries, LLC; SoloShot Xtreme or heavier as required for application: www.copperheadwire.com/.
 - 2) Pro-Line Safety Products Company; 4 AWG (7/32") 7x7 SST304 PE45: <http://www.prolinesafety.com>.
 - 3) Substitutions: See Section 01 60 00 - Product Requirements.
- C. Trace Box:
- 1. At Grade applications:
 - a. At grade terminal trace box shall include terminal connection lid with "sewer" or "water" cast into the cap.
 - b. Manufacturers:
 - 1) Copperhead Industries, LLC; Snakepit LD14*2T-ADJ-SW (lawn areas), CD14*2T-SW (concrete driveways and sidewalks), RB14*2T-SW (all other areas): www.copperheadwire.com/.
 - 2) Substitutions: See Section 01 60 00 - Product Requirements.
- D. Wire Connectors:
- 1. All mainline trace wires must be interconnected in intersections, at mainline tees and mainline crosses. At tees, the three wires shall be joined using a single 3-way lockable connector. At crosses, the four wires shall be joined using a 4-way connector. Use of two 3-way connectors with a short jumper wire between them is an acceptable alternative.
 - 2. Direct Bury Wire Connectors shall include 3-way lockable connectors and mainline to lateral lug connectors specifically manufactured for use in underground trace wire installation. Connectors shall be dielectric silicon filled to seal out moisture and corrosion, and shall be installed in a manner so as to prevent any uninsulated wire exposure.
 - 3. Manufacturers:
 - a. Copperhead Industries, LLC; Locking Connector LSC1230* and 3WB-01: www.copperheadwire.com/.
 - b. Pro-Line Safety Products Company; TL-LUG-SS – TRACER-LOCK DB Connector w/in-line tap min #18-8: <http://www.prolinesafety.com>.
 - c. Substitutions: See Section 01 60 00 - Product Requirements.
- E. Grounding:

1. Grounding of trace wire shall be achieved by use of a drive-in magnesium grounding anode rod with a minimum of 20 feet of #14 red HDPE insulated copper clad steel wire connected to anode (minimum 1.5 lb.) specifically manufactured for this purpose, and buried at the same elevation as the utility.
 2. Manufacturers:
 - a. Copperhead Industries, LLC; Magnesium Anode ANO-12*: www.copperheadwire.com/.
 - b. Pro-Line Safety Products Company; PTANODE12 – PRO-TRACE 1.5# Magnesium Grounding Anode 12 AWG: <http://www.prolinesafety.com>.
 - c. Substitutions: See Section 01 60 00 - Product Requirements.
- F. Trace wire and boxes shall be color coded in accordance with APWA UCC.
- G. Detectable Locator tape:
1. Manufacturers:
 - a. Pro-Line Safety Products Company; 10314XXX3 5.0 Mil, 6 inch Detectable Locator Tape: <http://www.prolinesafety.com>.
 - b. Substitutions: See Section 01 60 00 - Product Requirements.

PART 3 EXECUTION

3.01 INSTALLATION - GENERAL

- A. Trace wire installation shall be performed in such a manner that allows proper access for connection of line tracing equipment, proper locating of wire without loss or deterioration of low frequency (512Hz) signal for distances in excess of 1,000 linear feet, and without distortion of signal caused by multiple wires being installed in close proximity to one another.
- B. Trace wire systems must be installed as a single continuous wire, except where using approved connectors. No looping or coiling of wire is allowed.
- C. Any damage occurring during installation of the trace wire must be immediately repaired by removing the damaged wire, and installing a new section of wire with approved connectors. Taping and/or spray coating shall not be allowed.
- D. Trace wire shall be installed at the bottom half of the pipe and secured (taped/tied) at 5 foot intervals.
- E. Trace wire must be properly grounded as specified.
- F. At all mainline dead-ends, trace wire shall go to ground using an approved connection to a drive-in magnesium grounding anode rod, buried at the same depth as the trace wire.
- G. Mainline trace wire shall not be connected to existing conductive pipes. Treat as a mainline dead-end, ground using an approved waterproof connection to a grounding anode buried at the same depth as the trace wire.
- H. All service lateral trace wires shall be a single wire, connected to the mainline trace wire using a mainline to lateral lug connector, installed without cutting/splicing the mainline trace wire.
- I. In occurrences where an existing trace wire is encountered on an existing utility that is being extended or tied into, the new trace wire and existing trace wire shall be connected using approved splice connectors, and shall be properly grounded at the splice location as specified.
- J. A minimum of 2 feet of excess/slack wire is required in all trace wire access boxes after meeting final elevation.

- K. All trace wire access boxes must include a manually interruptible conductive/connective link between the terminal(s) for the trace wire connection and the terminal for the grounding anode wire connection.
- L. Grounding anode wire shall be connected to the identified (or bottom) terminal on all access boxes.
- M. Service Laterals on Public Property:
 - 1. Trace wire must terminate at an approved grade level/in-ground trace wire access box, located at the edge of the road right-of-way, and out of the roadway.
- N. Service Laterals on Private Property:
 - 1. Trace wire must terminate at an approved grade level/in-ground trace wire access box, located within 2 lineal feet of the building being served by the utility.
- O. Hydrants:
 - 1. Trace wire must terminate at an approved grade level/in-ground trace wire access box. Affixing with tape or plastic ties shall not be acceptable.
- P. Long-runs, in excess of 500 linear feet without service laterals or hydrants:
 - 1. Trace wire access must be provided utilizing an approved grade level/in-ground trace wire access box, located directly above the pipe, and out of the roadway. The grade level/ground trace wire access box shall be delineated using a minimum 48" polyethylene marker post, color coded in accordance with APWA UCC.
- Q. Grounding:
 - 1. Trace wire must be properly grounded at all dead end/stubs.
 - 2. When grounding the trace wire at dead ends/stubs, the grounding anode shall be installed in a direction 180 degrees opposite of the trace wire, at the maximum possible distance.
 - 3. When grounding the trace wire in areas where the trace wire is continuous and neither the mainline trace wire nor the grounding anode wire will be terminated at/above grade, install grounding anode directly beneath and in-line with the trace wire. Do not coil excess wire from grounding anode. In this installation method, the grounding anode wire shall be trimmed to an appropriate length before connecting to trace wire with a mainline to lateral lug connector.
 - 4. Where the anode wire will be connected to a trace wire access box, a minimum of 2 feet of excess/slack wire is required after meeting final elevation.
- R. Locator Tape:
 - 1. Locator tape shall be installed in accordance with manufacturer recommendations over all utilities.

3.02 INSTALLATION - SANITARY SEWER SYSTEM

- A. A mainline trace wire must be installed, with all service lateral trace wires properly connected to the mainline trace wire, to ensure full trace/locating capabilities from a single connection point.
- B. Lay mainline trace wire continuously, by-passing around the outside of manholes/structures on the North or East side.
- C. Trace wire on all sanitary service laterals must terminate at an approved trace wire access box color coded green and located directly above the service lateral at the edge of the road right-of-way.

3.03 INSTALLATION - WATER SYSTEM

- A. A mainline trace wire must be installed, with all service lateral trace wires properly connected to the mainline trace wire, to ensure full tracing/locating capabilities from a single connection point.
- B. Lay mainline trace wire continuously, by-passing around the outside of valves and fittings on the North or East side.
- C. Trace wire on all water service laterals and hydrants must terminate at an approved trace wire access box color coded blue and located directly above the service lateral at the edge of the road right-of-way.
- D. All conductive and non-conductive service lines shall include trace wire.

3.04 INSTALLATION - LOCATOR TAPE

- A. Install one foot below finished grade in accordance with Manufacturer's recommendations.

3.05 PROHIBITED PRODUCTS AND METHODS

- A. Uninsulated trace wire.
- B. Trace wire insulations other than HDPE.
- C. Trace wires not domestically manufactured.
- D. Non locking, friction fit, twist on or taped connectors.
- E. Brass or copper ground rods.
- F. Wire connections utilizing taping or spray-on waterproofing.
- G. Looped wire or continuous wire installations, that has multiple wires laid side-by-side or in close proximity to one another.
- H. Trace wire wrapped around the corresponding utility.
- I. Brass fittings with trace wire connection lugs.
- J. Wire terminations within the roadway, i.e. in valves boxes, cleanouts, manholes, etc.
- K. Connecting trace wire to existing conductive utilities.

3.06 FIELD QUALITY CONTROL

- A. All new trace wire installations shall be located using typical low frequency (512Hz) line tracing equipment, witnessed by the Contractor, Engineer and Owner as applicable, prior to acceptance of ownership.
- B. This verification shall be performed upon completion of rough grading and again prior to final acceptance of the project.
- C. Continuity testing in lieu of actual line tracing shall not be accepted.
- D. Utility will not be accepted until the trace wire has been located and tested.

END OF SECTION

SECTION 33 07 00
DIRECTIONAL DRILLING

PART 1 GENERAL

1.01 SECTION INCLUDES

- A. Directional drilling of force mains and water mains.

1.02 RELATED REQUIREMENTS

- A. Section 31 23 16.13 - Trenching.
- B. Section 33 06 00 - Trace Wire and Locator Tape.
- C. Section 33 09 01 - Installation and Acceptance Testing of Pipe and Accessories.
- D. Section 33 13 00 - Disinfecting of Water Utility Distribution.
- E. Section 33 14 16 - Water Piping.
- F. Section 33 31 23 - Sanitary Force Main Piping.

1.03 REFERENCE STANDARDS

- A. ASTM F1962-11 - Standard Guide for Use of Maxi-Horizontal Directional Drilling for Placement of Polyethylene Pipe or Conduit Under Obstacles, Including River Crossings; 2011.
- B. ASTM Volume 8, Issue 3 (March 2011) - Unique Calibration Case Study for Predictive Model of Installation Loads for Directional Drilled Fusible PVC Pipe; 2011.
- C. NSF/ANSI 60 - Drinking Water Treatment Chemicals - Health Effects; 2014.

1.04 SUBMITTALS

- A. See Section 01 30 00 - Administrative Requirements, for submittal procedures.
- B. Project Record Documents
 1. At the completion of the pilot hole drilling, the Contractor shall provide a tabulation of coordinates referenced to the drilled entry point which accurately describe the location of the pilot hole.
 2. Accurately record actual locations of piping mains, valves, connections, and invert elevations.
 3. Identify and describe unexpected variations to subsoil conditions or discovery of uncharted utilities.
 4. The Contractor shall utilize data collection technology to produce as-built profile drawings of the installed pipe.

PART 2 PRODUCTS

2.01 MATERIALS

- A. Fusible pipe and appurtenances in accordance with Section 33 06 00, Section 33 14 16 and/or Section 33 31 23.
- B. Drilling fluid shall meet NSF/ANSI 60 requirements for water main applications.

PART 3 EXECUTION

3.01 GENERAL

- A. Comply with the requirements of applicable specification sections and ASTM F1962-11 and/or ASTM Volume 8, Issue 3 (March 2011), if applicable, for the utility line being installed.
- B. Conduct any field surveys and subsurface investigations as necessary to complete the Work.
- C. Locate all known utilities and foundations/footings located adjacent to or crossing the utility line being installed.
 - 1. Excavate to expose utilities prior to initiating drilling and verify applicable clearances.
 - a. Clearances shall meet applicable code requirements and the requirements of the directional drilling process.
- D. Excavate insertion and receiving pits, and other access points as necessary to complete the Work in accordance with Section 31 23 16.13.
- E. In the event of difficulties at any time during drilling or ream and pullback operations requiring the complete withdrawal from the tunnel, the Contractor will be allowed to withdraw and abandon the tunnel and begin a second attempt at a location approved by the Village Engineer or qualified Village Agent.
 - 1. If the tunnel is abandoned before completion, Contractor shall seal and re-bore.
 - 2. In special circumstances, the Contractor may be allowed to excavate at the point of the difficulty and install the product pipe per the appropriate sections for open cut installation upon approval of the Village Engineer or qualified Village Agent.
- F. When an area of contaminated ground is encountered, all operations shall stop immediately and shall not proceed until approved by the Engineer. Any slurry shall be tested for contamination and disposed of in a manner that meets local, state and/or federal requirements.
- G. The Contractor shall perform the boring in accordance with the best industry practice and these Contract Documents.

3.02 DRILLING

- A. Drilling methods shall generally consist of drilling a pilot hole the length of the bore, followed by reaming and pullback of the pipeline. Ream borehole multiple times, as necessary. The equipment and methods used to complete the bore and install piping shall be determined by the Contractor, but subject to the Contract Documents.
- B. The Contractor shall keep drill staging area neat and orderly and disturb as little area as possible and shall disturb as little area as needed to accommodate pipe staging, workers and equipment, and to string, fuse, and inspect the pipe.
- C. Sufficient space shall be allocated to fabricate and layout the product pipeline into one continuous pipe length, thus enabling the pullback to be conducted during a single operation. If space considerations are discovered that make this impossible, Contractor shall obtain specific alternative instructions from Village Engineer or qualified Village Agent.
- D. The required piping shall be assembled in a manner that does not obstruct adjacent roadways or public activities.
- E. Install all pulleys, rollers, bumpers, alignment control devices and other equipment required to support and protect the new pipe from damage during installation.
- F. Utilize a drilling fluid cleaning/recycling system. Entry and exit pits shall be sized and constructed to completely contain drilling fluid.

- G. The pipe shall be installed along the path indicated on the Drawings to the following tolerances:
 - 1. Elevations - Plus or minus one (1') foot.
 - 2. Alignment - Plus or minus three (3') feet.
 - 3. Longitudinal and lateral variances for pipe end points shall be limited to three (3') feet with no depth variation.
- H. The radius of curvature of the pipe shall be in accordance with manufacturer's specifications.
- I. The entry angle of the pilot hole and the boring process must maintain a curvature that does not exceed the allowable bending radius of the product pipe.
- J. Alignment Adjustments and Restarts: The Contractor shall follow the pipeline alignment as indicated on the Drawings, within the specifications stated. If adjustments are required, Contractor shall notify Village Engineer or qualified Village Agent and receive approval prior to making the adjustments.
- K. The number of access pits shall be kept to a minimum and the equipment must be capable of boring the required lengths in a single bore.
- L. The Contractor shall at all times provide and maintain instrumentation which will accurately locate the pilot hole and measure drilling fluid quantity. The Contractor shall grant the Village Engineer or qualified Village Agent access to all data and readout pertaining to the position of the bore head, the fluid pressures, and flows.
- M. Within 48 hours of completing the pilot hole for each run of pipe, Contractor shall provide the log of the drilling operation and guidance system records documenting the line and grade of that pilot hole to the Village Engineer or qualified Village Agent.
- N. The Contractor shall notify the Village Engineer or qualified Village Agent upon completion of the pilot hole to observe alignment prior to reaming and pullback.

3.03 JOINING PIPE

- A. Fusion Joints:
 - 1. Sections of pipe shall be joined into continuous lengths on the jobsite above ground.
 - 2. The joining method shall be the butt fusion method and shall be performed in strict accordance with the pipe manufacturer's recommendations.
 - 3. The butt fusion equipment used in the joining procedures shall be capable of meeting all conditions recommended by the pipe manufacturer, including, but not limited to, temperature requirements, alignment and interfacial fusion pressure.
 - 4. The butt fusion joining shall produce a joint weld strength equal to or greater than the tensile strength of the pipe itself.
 - 5. All welds shall be made using a Data Logger to record temperature and fusion pressure, with graphic representation of the fusion cycle. This log shall be part of the Quality Control records.
- B. Sidewall fusions for connections to outlet piping shall be performed in accordance with pipe and fitting manufacturer's specifications.
- C. Mechanical joining may be used where the butt fusion method cannot be used.
 - 1. Join HDPE and Fusible PVC pipe to mechanical joint or flanged fittings in accordance with both fitting and pipe manufacturer's requirements.
- D. Connect terminal sections of pipe that are joined within excavations with electrofusion couplings.

3.04 REAM AND PULL BACK

- A. Prereaming - Prereaming operations shall be conducted at the discretion of the Contractor. All provisions of this specification relating to the simultaneous reaming and pulling back operations shall also pertain to prereaming operations.
- B. Reaming diameter shall not exceed 1.4 times the diameter of the product pipe being installed.
- C. Pulling Loads - The pull force exerted on the pipe during installation of the pipe shall not exceed the manufacturer's published pull strength of the pipe.
- D. The amount of pull applied to the pipe shall be controlled and limited by devices such as a hydraulic pressure regulator or a load sensor between the pulling equipment and the pipe.
- E. Torsional Stress - A swivel shall be used to connect the pull section to the reaming assembly to minimize torsional stress imposed on the section.
- F. Pull Section Support - Provide supports/rollers in accordance with manufacturer's recommendations. Supports and rollers shall allow for free movement of the pipeline and prevent damage to the pipe.
- G. Use drilling fluid in conjunction with the installation of the pipe to fill the annular space around the installed pipeline. The drilling fluid shall remain in place to provide support for the pipe and neighboring soil. Contractor shall be responsible for determining the type of fluid to be used, and for properly disposing of all excess drilling fluid and slurry material recovered from the hole during drilling operations and displaced by the pipe during installation.
- H. The Contractor shall allow sufficient length of product pipe to extend past the termination point to allow connections to adjacent pipe sections or valves.
- I. Pipe ends shall be temporarily sealed with a cap until the connection is made permanent, to prevent water or earth infiltration.
- J. Allow the manufacturer's recommended amount of time for cooling and relaxation due to tensile stressing prior to connecting pipe to adjacent pipe sections, fittings, or structures, or backfilling of the insertion pit. Provide sufficient excess length of new pipe at insertion pits to allow for cooling and relaxation.
- K. Install trace wire during pullback operations. Extend trace wire as specified in Section 33 06 00 to end of pipe and secure in accordance with trace wire manufacturer's recommendations.

3.05 GUIDED BORING OPERATIONS

- A. Equipment - The drilling equipment must be capable of placing the pipe within the planned line and grade without inverted slopes. The drilling equipment must have a minimum pullback rating of 30,000 lbs, torque rating of 2,000 ft/lbs, and mudflow of 24 gpm.
- B. Guidance System:
 - 1. The guidance system must have the capability of measuring inclination, roll and azimuth.
 - 2. The guidance system must have an independent means to ensure the accuracy of the installation.
 - 3. The Contractor must demonstrate a viable method to eliminate accumulated error due to the inclinometer (pitch or accelerometer).
 - 4. The guidance system must be capable of generating a plot of the borehole survey for the purpose of an as-built drawing.

3.06 TESTING AND DISINFECTION

- A. Water main and force main shall be hydrostatically tested in accordance with Section 33 09 01.

B. Water main shall be disinfected in accordance with Section 33 13 00.

END OF SECTION

SECTION 33 08 00
SEWER BYPASS FLOW CONTROL

PART 1 GENERAL

1.01 SECTION INCLUDES

- A. Dewatering or diverting the existing flow in sewers to the degree necessary for cleaning and inspecting of sewers, or manhole and sewer rehabilitation procedures.

1.02 RELATED REQUIREMENTS

- A. Section 33 09 00 - Sewer Cleaning and Televising.
- B. Section 33 09 01 - Installation and Acceptance Testing of Pipe and Accessories.

1.03 SUBMITTALS

- A. See Section 01 30 00 - Administrative Requirements, for submittal procedures.
- B. Furnish to Engineer for approval the proposed method of dewatering sewers a minimum of 5 days prior to starting Work.

PART 2 PRODUCTS

2.01 EQUIPMENT

- A. All necessary Contractor supplied equipment to perform Work.

PART 3 EXECUTION

3.01 GENERAL

- A. Depth of Flow:
 - 1. When sewer line depth of flow, as measured at the upstream manhole of the sewer section where Work is to be performed, is above the maximum allowable level specified herein, reduce the flow level by plugging or blocking of the flow, or pumping and bypassing of the flow as specified.
 - 2. Do not exceed depth of flow shown below for the respective pipe sizes as measured in the upstream manhole when performing television inspection or joint testing and/or sealing.
 - a. Television Inspection:
 - 1) 6 inch to 10 inch pipe: 20% of the pipe diameter
 - 2) 12 inch to 24 inch pipe: 25% of the pipe diameter
 - 3) 27 inch and larger pipe: 30% of the pipe diameter
 - b. Joint Testing and/or Sealing:
 - 1) 6 inch to 12 inch pipe: 25% of the pipe diameter
 - 2) 15 inch to 24 inch pipe: 30% of the pipe diameter
 - 3) 27 inch and larger pipe: 35% of the pipe diameter
 - 3. Plugging or Blocking:
 - a. Insert a sewer line plug into the line upstream of the sewer section in which Work is to be performed.

- b. Design the plug so that all or any portion of the sewage can be released.
 - c. During television inspection, testing and/or sealing operations, reduce the flow level to within the limits specified above.
 - d. After the Work has been completed, restore the flow to normal.
4. Pumping and Bypassing:
- a. When pumping and bypassing is required, supply the pumps, conduits, and other equipment to divert the flow of sewage around the sewer section in which Work is to be performed.
 - b. The bypass system must be of sufficient capacity to handle existing flow plus additional flow that may occur during a storm event.
 - c. Commencement of bypass pumping operations when a storm event is imminent will not be allowed, and must be delayed until the threat of rainfall has passed.
 - d. The Contractor will be responsible for furnishing the necessary labor and supervision to commission and operate the pumping and bypassing system.
 - e. If pumping is required on a 24 hour basis, sound attenuated generators shall be required.
5. Flow Control Precautions:
- a. When flow in a sewer line is plugged, blocked or bypassed, take sufficient precautions to protect the sewer lines from damage that might result from sewer surcharging.
 - b. Take precautions to ensure that sewer flow control operations do not cause flooding or damage to public or private property being served by the sewers involved.
 - c. At no time shall sanitary sewage be pumped in or allowed to flow into a catch basin, storm sewer, or open watercourse.
 - d. Repair or replace leaking hoses and couplings immediately.

END OF SECTION

SECTION 33 09 00
SEWER CLEANING AND TELEVISIONING

PART 1 GENERAL

1.01 SECTION INCLUDES

- A. Television inspection of all new and reconstruction of any storm or sanitary sewer lines including the necessary cleaning of sewer lines.

1.02 RELATED REQUIREMENTS

- A. Section 33 05 13 - Manholes and Structures.
- B. Section 33 08 00 - Sewer Bypass Flow Control.
- C. Section 33 31 13 - Sanitary Sewer Piping.
- D. Section 33 42 11 - Storm Sewer Piping.

1.03 REFERENCE STANDARDS

- A. MDOT Standard Specifications for Construction - Section 402.03.K - Video Inspection of Sewer Pipe; 2012.
- B. NASSCO-PACP - National Association Of Sewer Service Companies - Pipeline Assessment Certification Program (PACP); 2017.

1.04 SUBMITTALS

- A. See Section 01 30 00 - Administrative Requirements, for submittal procedures.
- B. Provide the Engineer with 3 copies of the televising video in USB flash drive format, along with 1 copy of paper report of the televising activities. Videos must be formatted MPEG1 unless otherwise directed by the Engineer.

1.05 QUALITY ASSURANCE

- A. Televiser Qualifications: Company specializing in performing Work by CCTV personnel who are trained and certified in the use of NASSCO-PACP and with minimum 3 years of documented experience.

PART 2 PRODUCTS

2.01 EQUIPMENT

- A. Cleaning Equipment:
 - 1. Hydraulically Propelled Equipment:
 - a. Use the equipment of a movable dam type and construct in such a way that a portion of the dam may be collapsed at any time during the cleaning operation to protect against flooding of the sewer.
 - 1) The movable dam must be equal in diameter to the pipe being cleaned and provide a flexible scraper around the outer periphery to insure removal of grease.
 - b. If sewer cleaning balls or other equipment which cannot be collapsed is used, special precautions to prevent flooding of the sewers and public or private property shall be taken.
 - 2. High-Velocity Jet (Hydrocleaning) Equipment:
 - a. Construct all high-velocity sewer cleaning equipment for ease and safety of operation.

- b. The equipment must have a selection of two or more high-velocity nozzles.
 - c. The nozzles must be capable of producing a scouring action from 15 to 45 degrees in all size lines designated to be cleaned.
 - d. Include a high-velocity gun for washing and scouring manhole walls and floor, capable of producing flows from a fine spray to a solid stream.
 - e. The equipment must carry its own water tank, auxiliary engines, pumps, and hydraulically driven hose reel.
3. Mechanically Powered Equipment:
- a. Bucket machines must be in pairs with sufficient power to perform the Work in an efficient manner.
 - b. Where bucket machines and buckets are to be used, caution should be taken that a proper sized flexible cable be used so that cable breakage will not occur.
 - c. Machines must be belt operated or have an overload device.
 - d. Machines with direct drive that could cause damage to the pipe will not be allowed.
 - e. A power rodding machine must be either a sectional or continuous rod type capable of holding a minimum of 1,000 feet of rod. The rod must be specifically heat treated steel.
 - f. To insure safe operation, the machine must be fully enclosed and have an automatic safety clutch or relief valve.
4. Large Diameter Cleaning:
- a. For cleaning large diameter sewer (sewer ranging 27" to 108" in diameter), storm or combination pipes, consideration should be given to a combination hydraulic high volume water and solids separation system.
 - b. Confirm that the flow from the sewer will provide water for the pump operation so no potable water is necessary and treatment costs are not a factor.
 - c. Water volume of up to 250 GPM at 2000 PSI+ will move solids to the downstream manhole in high flow conditions.
 - d. The separation system will dewater solids to 95% (passing a paint filter test) and transfer them to a dump truck for transport to a sewage treatment plant or approved landfill.
 - e. Sewer water shall be filtered to a point where it can be used in the pump for continuous cleaning.
 - f. No by-passing of sewer flows should be necessary.
 - g. The unit must be capable of 24 hour operation and must not leave the manhole until a section is fully cleaned.
 - h. Equipment must be able to clean the length with vehicular access to one manhole only.
- B. Televising Equipment:
- 1. The television camera used for the inspection must be one specifically designed and constructed for such inspection.
 - 2. Equipment shall include Pan/Tilt/Rotate/Lateral Launch features to inspect all service lateral connections to determine whether the lateral is active or plugged and to inspect the structural integrity of the lateral and connection to the sewer main and where practical to provide additional information such as wide joints, holes in pipe, etc.
 - 3. Lighting for the camera must be suitable to allow a clear picture of the entire periphery of the pipe.

4. The camera must be operative in 100% humidity conditions. Position the camera lens looking along the axis of the sewer and within 10% of the vertical centerline of the pipe.
5. The camera, television monitor, and other components of the video system must be capable of producing picture quality to the satisfaction of the Village Engineer or qualified Village Agent; and if unsatisfactory, equipment must be removed.
6. Manual winches, power winches, TV cable, and powered rewinds or other devices that do not obstruct the camera view or interfere with proper documentation of the sewer conditions may be used to move the camera through the sewer line.

2.02 SOFTWARE

A. Database Requirements:

1. The software is PACP certified by NASSCO.
2. The software can export to the standard PACP database.
3. The software can import from the standard PACP database.
4. The software shall be compatible with Microsoft Windows 7 and later operating systems.
5. The footage reading from the camera equipment shall be automatically entered into the Survey Log.
6. The inspection and reporting software program will be menu driven.
7. A context sensitive complete on screen help file will be available.
8. Drop-down boxes shall be utilized to quickly reference common information as specified by the PACP standard such as defects, pipe materials, survey purpose, locations, pipe usage, etc.
9. The basic module software shall also have search (filter) capabilities in order to find information about past surveys located in the database(s).
10. The basic module software shall maintain a database of underground pipe and manhole assets. The entry form shall allow additional detail about the pipe to be added including map coordinates.
11. A Reader shall be provided for viewing and printing all information. JPEG files can be taken using the Reader from the mpeg file.
12. A Site sketch feature shall also be supplied so that a drawing or sketch will indicate special details or locations about a particular set-up site.

PART 3 EXECUTION

3.01 CLEANING

A. General:

1. Provide necessary equipment and personnel for dislodging of material from the sewer pipe, removal of the debris from the system and the transport and disposal of debris removed.
2. A disposal site may, upon prior approval, be provided by the Owner.
3. Remove foreign materials from the lines and restore the sewer to a minimum of 95% of the original carrying capacity or as required for proper seating of internal pipe joint sealing packers.
4. It is recognized that there are some conditions such as broken pipe and major blockages in aged systems that prevent cleaning from being readily accomplished or where additional damage would result if cleaning were attempted or continued.

- a. Should such conditions be encountered, the Contractor, at the sole discretion of the Engineer, may not be required to clean those specific sewer sections.
- B. Cleaning Precautions:
 - 1. During sewer cleaning operations, satisfactory precautions must be taken in the use of cleaning equipment.
 - 2. When hydraulically propelled cleaning tools (which depend upon water pressure to provide their cleaning force) or tools which retard the flow in the sewer line are used, take precautions to ensure that the water pressure created does not damage or cause flooding of public or private property being served by the sewer.
 - 3. All damages to the private property, which result from backflushing sewer laterals, are the sole responsibility of the Contractor.
 - 4. When additional water from fire hydrants is necessary to avoid delay in normal Work procedures, the water must be purchased from the Owner at a cost as determined in the **FEE SCHEDULE**.
 - 5. Fire hydrants shall be accessible to emergency vehicles at all times.
- C. Sewer Cleaning Methods:
 - 1. Clean the designated sewer sections using hydraulically propelled, high-velocity jet, or mechanically powered equipment.
 - 2. Base the selection of the equipment used on the conditions of lines at the time the Work commences.
 - 3. The equipment and methods selected must be satisfactory to the Village Engineer or qualified Village Agent.
 - 4. If cleaning of an entire section cannot be successfully performed from one manhole, the Contractor must relocate his equipment so that the cleaning can be performed from the opposite structure.
- D. Root Removal:
 - 1. Remove roots in the sections where root intrusion is a problem.
 - 2. Special attention should be used during the cleaning operation to assure removal of roots from the joints.
 - 3. Any roots which could prevent the seating of the packer or could prevent the proper application of chemical sealants must be removed.
 - 4. Procedures may include the use of mechanical equipment such as rodding machines, bucket machines and winches using root cutters and porcupines, and equipment such as high-velocity jet cleaners.
- E. Removal and Disposal of Debris:
 - 1. All sludge, dirt, sand, rocks, grease, roots and other solid or semisolid material resulting from the cleaning operation must be removed at the downstream manhole of the section being cleaned.
 - 2. Passing material from sewer section to sewer section will not be permitted.
 - 3. Remove all material from the Site no less often than at the end of each workday.
 - 4. Under no circumstances will the Contractor be allowed to accumulate debris, etc., on the Site beyond the stated time, except in totally enclosed containers and as approved by the Village Engineer or qualified Village Agent.
- F. Acceptance of Sewer Cleaning:
 - 1. Acceptance of sewer line cleaning will be made upon the successful completion of the television inspection and must be to the satisfaction of the Village Engineer or qualified Village Agent.
 - 2. If the television inspection shows the cleaning to be unsatisfactory, the Contractor will be required to re-clean and re-inspect the sewer line, until the cleaning is shown to be satisfactory.

3.02 TELEVISIONING

A. General:

1. The Village Engineer or qualified Village Agent shall directly supervise televising and view recordings.
2. Perform Work in accordance with MDOT Standard Specifications for Construction - Section 402.03.K.
3. Televising all sanitary and storm mains, sanitary laterals, and storm underdrains.
4. Perform inspection at rate of speed which will allow examination of all points of infiltration, cracked or crushed pipe, defective joints, misalignment in line or grade, location of wye openings and other defects.
5. Camera lens must be clean and dry at the beginning of each pipe run.
6. Move the camera through the line in either direction at a moderate rate, stopping when necessary to permit proper documentation of the sewer's condition.
7. In no case will the television camera be operated at a speed greater than 30 feet per minute.
8. If, during the inspection operation, the television camera will not pass through the entire manhole section, the Contractor must relocate his equipment so that the inspection can be performed from the opposite structure.
9. Precisely locate and describe by detailed statement, condition of any item, which in the opinion of the Village Engineer or qualified Village Agent requires repair.
10. As a part of television inspection, note precise location of each wye or tee in relation to downstream manhole. Record this information on the as-built drawings supplied by Contractor.
11. If camera encounters dips in existing sewers being televised such that water is standing above springline of sewer pipe, and if camera lens becomes submerged because of this condition, withdraw camera rig from sewer and insert from other end as far as possible. Prevent back flooding into section being televised from adjacent section.
12. Video recording playback must be at the same speed that it was recorded. Slow motion or stop-motion playback features may be supplied at the option of the Contractor.
13. The Contractor must have all video and necessary playback equipment readily accessible for review by the Owner during the project.
14. The Village Engineer or qualified Village Agent's project number, date of televising, manhole/catchbasin numbers, location, direction of flow, pipe diameter/size, pipe material, name of operator, and the report number must appear transparent in the middle of the viewing screen at the start of the televising video.
15. The manhole/catchbasin numbers and location must appear transparent throughout the televising and displayed in the bottom left or right quadrant without obstruction to viewing the condition of the pipe.

B. Digital Video/Audio Recording Requirements:

1. Continuous digital video recordings of the inspection view as it appears on the television monitor shall be made. The recording shall be used as a permanent record of defects. The digital video encoding shall include both sound and video information.
2. Images or video clips shall be easily launched for viewing during inspection report review.
3. Video logging and image capturing shall be available to enter video surveys either in real time or at a later time from previously videotaped inspections.
4. The user will be able to select MPEG 1, WMV or MPEG 2 as a recording Standard.
5. The MPEG or WMV files can be created from the live video or from recorded video files.

6. As each observation is saved, the time link into the MPEG will be automatically recorded.
 7. The recording will be able to be paused for brief periods.
 8. The recording will be able to be stopped and be able to be continued via the APPEND feature.
 9. Playback speed shall be continuously adjustable from one-quarter normal speed to ten times normal speed with no video distortion.
 10. The Live Video, as well as the recorded video may be played side by side on screen for comparison.
- C. Reporting Capabilities:
1. If the television inspection of an entire section (manhole to manhole) cannot be successfully performed from one manhole, a reverse setup shall be performed per PACP requirement as a second survey. Both of these inspections shall be displayed as a single report in Pipe Graphic and Tabular Reports.
 2. Section summary reports are to be made available so that all surveys within a section are listed showing purpose of inspection, dates, work order numbers, manholes, road names and total lengths.
 3. Service and structural aspect scoring reports are to list the pipe segment reference number, total observed length, number of defects and total score with reference to the condition of the total pipe, average of the pipe, total defects and average of defects.
 4. PACP Quick Rating Report will be available.

END OF SECTION

SECTION 33 09 01

INSTALLATION AND ACCEPTANCE TESTING OF PIPE AND ACCESSORIES

PART 1 GENERAL

1.01 SECTION INCLUDES

- A. Installation and acceptance testing of gravity and pressurized piping systems.

1.02 RELATED REQUIREMENTS

- A. Section 31 23 16.13 - Trenching.
- B. Section 33 05 13 - Manholes and Structures.
- C. Section 33 06 00 - Trace Wire and Locator Tape.
- D. Section 33 08 00 - Sewer Bypass Flow Control.
- E. Section 33 09 00 - Sewer Cleaning and Televising.
- F. Section 33 13 00 - Disinfecting of Water Utility Distribution.
- G. Section 33 14 16 - Water Piping.
- H. Section 33 31 13 - Sanitary Sewer Piping.
- I. Section 33 31 23 - Sanitary Force Main Piping.
- J. Section 33 42 11 - Storm Sewer Piping.

1.03 FIELD CONDITIONS

- A. Existing conditions:
 - 1. Verify existing piping and penetrations.
 - 2. Prior to ordering materials, expose all existing pipes which are to be connected to new pipelines.
 - 3. Verify size, material, joint types, elevation, horizontal location, and pipe service of existing pipes.
 - 4. Inspect size and location of structure penetrations to verify adequacy of wall sleeves and other openings before installing connecting pipes.

1.04 SUBMITTALS

- A. See Section 01 30 00 - Administrative Requirements, for submittal procedures.
- B. Specification sheet for mandrel manufacturer.
- C. Location, size and material of uncharted utilities encountered during excavation using survey grade equipment and locating items in State Plane Coordinate System (SPCS).

PART 2 PRODUCTS

2.01 EQUIPMENT

- A. All necessary Contractor supplied equipment to perform Work.

PART 3 EXECUTION

3.01 INSTALLATION - GENERAL

- A. Perform Work in accordance with applicable code(s).
- B. Perform trenching for piping installation in accordance with Section 31 23 16.13.
- C. Install pipe, fittings, and accessories at the locations and elevations indicated on Drawings and in accordance with manufacturer's instructions. Seal watertight.
 - 1. Ductile Iron: Comply with AWWA C600.
 - 2. PVC/PVCO (C900, C905, C909): Comply with AWWA C605 and AWWA M23.
 - 3. HDPE: Comply with AWWA M55 and ASTM D2774.
 - 4. PVC (SDR 23.5, 26, 35): Comply with ASTM D2321.
- D. Install access fittings as necessary to permit disinfection of water system performed under Section 33 13 00.
- E. Install trace wire in accordance with Section 33 06 00.

3.02 INSTALLATION - PIPE

- A. Maintain horizontal separation of water main from sanitary and storm piping of at least 10 feet in all horizontal directions.
- B. Maintain vertical separation of water main from sanitary and storm piping of at least 18 inches in all vertical directions.
- C. At crossings, one full length of pipe shall be located such that both joints will be as far from the existing utility as possible.
- D. Verify trench cut is ready to receive Work and excavations, dimensions, and elevations are as indicated on Drawings.
- E. Before lowering and while suspended, inspect pipe and each fitting for defects. Installation of defective material is not permitted.
- F. Where pipe, fittings or joint materials have been soiled by earth in handling, thoroughly clean soiled surfaces until all traces of earth are removed before joining pipe.
- G. Alignment:
 - 1. Gravity Piping:
 - a. Run gravity piping in a straight line.
 - b. All pipes shall be laid to line and grade. They shall be carefully centered so that when laid they form a pipe run with a uniform invert.
 - c. Alignment Laser:
 - 1) In straight piping between structures, the Contractor shall use a suitable alignment laser for horizontal and vertical alignment.
 - 2) The alignment laser shall be of a type and manufacture especially suitable to the construction of sewers and the instrument shall provide a target which shall insure an instant and continuous visual check on the instrument alignment.

- 3) A competent and skilled superintendent or operator for the laser beam instrument shall be on duty at all times.
2. Pressure Piping:
 - a. Run pressure piping as straight as practical in alignment shown with minimum of joints.
 - b. Establish elevations of buried piping to ensure not less than 5.5 ft of cover or as otherwise indicated on Drawings.
- H. Laying Pipe:
1. Gravity Piping:
 - a. Install gravity pipe with bell ends facing the direction of laying, proceed upward against the direction of flow unless otherwise indicated on drawings.
 - b. When new sanitary sewer mains connect to existing sewers at manholes, the downstream end of the new sewer shall be plugged during the construction period and until the new sewer is inspected, cleaned, tested, and otherwise accepted by the Owner. Appropriate measures shall be taken to assure construction debris, dirt, ditch water, etc. are not allowed into the existing sewer.
 2. Pressure Piping:
 - a. Install force mains with a minimum grade of 1 percent downhill slope away from sewage air release valve to force entrapped air to accumulate at air release valve unless otherwise indicated on drawings.
 - b. Install water mains with bell ends facing the direction of laying unless otherwise indicated on drawings.
 - c. Where pressure pipe is laid on a grade of 10 percent or greater, start at bottom and proceed with bell ends of pipe facing upgrade.
- I. Maintain interior of all pipes thoroughly clean. After each pipe has been laid, carefully inspect, identify and remove pipe cuttings and filings, dirt, trash, rags and other foreign matter from interior.
- J. Protect completed Work by closing pipe openings with caps or plugs before, during, and after installation.
- K. As soon as possible after the joint is made, sufficient embedment material shall be placed along each side of the pipe to offset conditions which might tend to move the pipe off line and grade.
- L. Backfill trenches immediately after the pipe has been installed.
1. Do not displace or damage pipe when backfilling or compacting.
- M. Install piping to allow for thermal expansion and contraction resulting from difference between temperature during installation and during operation.
1. Install anchors as necessary.
- N. Couplings, Adapters and Service Saddles:
1. Install in accordance with manufacturer's instructions.
- O. Restrained Joints for Pressure Piping:
1. Contractor shall furnish and install joint restraints as necessary.
 2. Ductile Iron Pipe: Design and install in accordance with DIPRA TRD. Joints shall be push-on locking type gaskets, concrete thrust blocks are prohibited.
 3. Plastic Pipe: Design and install in accordance with AWWA/ASTM standards. Joints shall be push-on locking type gaskets, concrete thrust blocks are prohibited.

- P. Provide concrete cradles and encasement for pipe conflicts as indicated on Drawings or as directed by Village Engineer or qualified Village Agent.
- Q. Concrete Thrust Blocks, when approved for special circumstances only, shall meet the following requirements:
 1. Concrete shall be MDOT grade S1 or S2.
 2. Thrust block shall be poured against undisturbed earth.
 3. Bolts, fittings and joints shall be kept clear of concrete if practicable.
 4. The cross section of the thrust block shall be square.

3.03 INSTALLATION - VALVES

- A. Set valves on solid bearing.
- B. Center and plumb valve box over valve. Set box cover flush with finished grade.
- C. Clean valves of foreign matter prior to installation and inspect for damage. Fully open and close valves to verify parts are properly operating.
- D. Install valves with stem oriented in the vertical position.
- E. Install valves in valve manholes as indicated on Drawings.
- F. Valves shall generally be located such that they will not be in sidewalks, driveways, or in roads, unless otherwise directed by Village Engineer or qualified Village Agent.
- G. Valve manholes shall be clean, watertight and free from all infiltration prior to acceptance.

3.04 INSTALLATION - HYDRANTS

- A. Clean hydrants of foreign matter prior to installation and inspect for damage. Fully open and close valves to verify parts are properly operating.
- B. Set hydrants plumb; locate pumper nozzle perpendicular to and facing roadway.
- C. Set hydrants to grade, with nozzles at least 24 inches above ground.
- D. Locate control valve 36 inches away from hydrant.
- E. Provide a drainage pit 36 inches square by 24 inches deep filled with MDOT 6A washed, crushed stone.
- F. Encase elbow of hydrant in MDOT 6A washed, crushed stone to 6 inches above drain opening.
- G. Install drain plugs unless otherwise directed by the Village Engineer or qualified Village Agent.
- H. Painting:
 1. Hydrants shall be painted. Color shall be red, or a color approved by Village Engineer or qualified Village Agent.
 2. All pipe, bells, bolts, and any other portions of the watermain exposed inside manholes or other structures or hydrants with damaged coatings shall receive one coat of Tnemec 37-77 Chem-Prim and two (2) coats of Tnemec TNEME-GLOSS of paint or equal material approved by Village Engineer or qualified Village Agent.
 3. All items to be painted shall be dry and clean before application of paint. Any rust or scale shall be removed by wire brushing or scraping prior to painting as directed by Village Engineer or qualified Village Agent. If necessary, heat shall be provided to maintain good drying conditions.

3.05 INSTALLATION - STUBS AND SERVICE LEADS

A. General:

1. Where indicated on Drawings, each property shall be provided a sanitary and water service lead.
 - a. Water leads shall terminate with a curb stop and curb box. Cap house side of curb stop.
2. Sanitary risers shall provide basement service as necessary.
 - a. In all depths over 12 feet, a riser shall be provided with two 45 degree long radius elbows and sufficient pipe to bring the top of the riser to within 8.5 feet of the finished grade at the right-of-way line or as directed by the Engineer.
 - b. Backfill at all risers shall be carefully placed and tamped sufficiently to insure against damage from backfill settlement.
3. Existing house sanitary and storm service leads encountered in the excavation shall be temporarily reconnected to the existing sewer until the new sewer has been completely tested and approved.
 - a. No connections to new sewers will be allowed until tested and approved.
4. After each section of new main/lead has been tested and approved, the Contractor shall connect all existing service leads to the new system. Connection of existing sewers to the new sewer before testing will not be allowed unless testing is waived by the Village Engineer or qualified Village Agent.
5. When leads are to be cut into an existing clay sanitary sewer, a tap shall be made with the use of an approved saddle. When leads are cut into an existing PVC sanitary sewer, a tap shall be made by removing a section of the existing pipe, installing a new wye, and connecting with approved PVC repair couplers with a same SDR rating as the pipe.

B. Sanitary Manhole Connections:

1. Where indicated on the Drawings or as directed by the Engineer, service leads shall be connected to manholes.
2. Connections shall be field cored and booted with a flexible rubber connector; installed to a water tight condition; external drop pipe installed if the service lead invert is greater than 24 inches above the main sewer flow line; and the flow channels shaped to assure smooth hydraulic flows.
3. Stubs for future sewer extension shall be of the length indicated on Drawings and terminate with a 2 foot section of pipe inserted into the bell end of the downstream pipe and capped.

C. Pipe Tap Connections for Pressure Piping:

1. Ductile Iron Piping: Use service saddle or tapping boss of a fitting, valve body, or equipment casting if recommended by manufacturer. Taps direct to pipe barrels will be considered depending on wall thickness.
2. Plastic Piping: Use service saddle or tapping boss of a fitting, valve body, or equipment casting.

D. Marking Stubs and Storm and Sanitary Leads:

1. In order to mark the location of unconnected stubs and storm and sanitary service lead connections, the Contractor shall make accurate measurements of all stubs and service leads before the trench is closed.
2. The Contractor shall keep a record of the distance of each service lead connection from the nearest downstream manhole and his record shall be furnished to the Engineer upon request.
3. The Contractor shall mark each unconnected stub and service connection by the following method(s):

- a. Placing a 4 inch by 4 inch cypress, ash, or cedar marking stick extending from the invert of the capped stub or service lead, terminating 3 feet above finish grade.
- b. Placing a number 4 rebar extending from the invert of the capped stub or service lead, terminating 6 inches below finished grade.
- c. Install trace box within one foot of 4x4 post.

3.06 INSTALLATION - DRIVEWAY CULVERTS

- A. The minimum length of a culvert may be determined as the width of the approach over the culvert plus 6 feet each side. The maximum slope from driveway to ditch invert is 1:3. The Engineer reserves the right to require longer culverts and flatter slopes, depending on Site specific conditions.
- B. The use of sloped culvert end sections is required.
- C. The use of culvert headwalls is prohibited.
- D. The enclosure of ditches must be approved by the Village Engineer or qualified Village Agent.
- E. Culverts shall be installed in line with and on the same grade as the road ditch. The Engineer may require modifications to the ditch in order to provide adequate cover over the culvert. The cover, or depth of material over the culvert, should be equal to or greater than the diameter of the culvert.
- F. A minimum twelve-inch (12") diameter culvert is required. All culverts should be corrugated metal pipes made with steel of the proper gauge corresponding to its diameter, as shown below.

<u>Diameter</u>	<u>Gauge No.</u>
12" - 24"	16
30" - 36"	14
42" - 54"	12
60" - 72"	10

3.07 FIELD QUALITY CONTROL - GRAVITY SANITARY SEWER

- A. Perform acceptance testing in accordance with manufacturer's instructions and the following:
 - 1. All sewers shall be subjected to the following tests witnessed and approved by the Engineer prior to acceptance of the sanitary sewer.
 - a. Alignment
 - b. Low-pressure air:
 - 1) Sewer pipe 18 inches and smaller.
 - 2) Sewer pipe larger than 18 inches (or smaller diameters based on ground water conditions) shall be tested by either infiltration or exfiltration and shall be tested in lengths approved by the Village Engineer or qualified Village Agent.
 - c. Deflection
 - d. Television
 - e. Infiltration test:
 - 1) If ground water level is 2 feet or more above the top of the pipe at the upstream end, or if the air pressure required for the test is greater than 9-psig.
 - f. Exfiltration test:

- 1) If ground water level is 2 feet or less above the top of the pipe at the downstream end and pipe diameter is larger than 18 inches.
2. Verify ground water level to determine appropriate leakage testing method.
 - a. Remove cap from pipe nipple.
 - b. Clear pipe nipple with air pressure.
 - c. Connect a clear plastic tube to nipple.
 - d. Support tube vertically and allow water to rise in the tube.
 - e. After water stops rising, measure height in feet of water over crown of the pipe.
 3. The Contractor shall furnish all equipment and personnel to conduct system acceptance tests as specified herein on all completed sewers.
 4. If any section of the sewer fails to meet acceptance testing requirements, the Contractor shall perform a television inspection of the faulty section and repair or replace at his own expense all defective materials and/or workmanship to the satisfaction of the Village Engineer or qualified Village Agent. The test procedure shall be repeated until the results are acceptable.
 5. The outlet pipe from Sanitary Test Manholes shall be plugged with a waterproof stopper to prevent discharge to the existing system until acceptance of the system by the Village Engineer or qualified Village Agent.
 6. All visible leakage shall be repaired as directed by the Village Engineer or qualified Village Agent, even though air tests and infiltration/exfiltration tests may have been satisfactorily completed.
 7. Sewer lines shall be cleaned and televised in accordance with Section 33 09 00 and, if required, bypassed in accordance with Section 33 08 00.
 - a. Existing sewer lines within the influence of proposed construction to remain in service shall be cleaned and televised prior to and after construction. Any damage determined to be caused by negligence of the Contractor shall be repaired at no cost to the Owner.
 - b. New sewer lines shall be cleaned and televised after construction.
 - c. Cleaning and televising schedule shall take into consideration other elements of Work.
 - d. Upon request by the Engineer, the Contractor shall provide a manifest receipt from the disposal site to verify proper disposal of sediment.
- B. Alignment Testing:
1. An alignment test may be required by the Village Engineer or qualified Village Agent.
 2. If required, the Contractor shall shine a light through the pipe at a manhole and view the light from an adjacent manhole.
 3. Any section of sewer in which a light cannot be seen from one manhole to the next shall be corrected to the satisfaction of the Village Engineer or qualified Village Agent.
- C. Low-Pressure Air Testing:
1. All sewer lines shall be clean and free of debris prior to air testing.
 2. The Contractor may desire to make an air test prior to backfill for his own purposes, however, the line acceptance test shall be conducted only after backfilling or extensions are completed.
 3. After a manhole-to-manhole section of line has been backfilled and is ready for testing, it shall be plugged at each manhole with pneumatic plugs. The design of the pneumatic plugs shall be such that they will hold against the line test pressure without requiring external blocking or bracing.

4. There shall be three (3) hose connections to the pneumatic plug.
 - a. One hose shall be used for inflation of the pneumatic plug.
 - b. One hose shall be used for continuously reading the air pressure in the sealed line.
 - c. One hose shall be used for introducing low-pressure air into the sealed line.
 5. There shall be a 0-30 psig gauge for reading the internal pressure of line being tested. Calibrations from the 1-10 psig gauge shall be in tenths of pounds (not ounces) and this 0-10 portion shall cover ninety percent (90%) of the completed dial gauge.
 6. The Contractor shall conduct a line acceptance test using low pressure air testing on all newly constructed PVC sanitary sewer lines, including private sewer lines.
 7. Perform air testing in accordance with ASTM F1417 - 11a and UNI-B-6-98.
- D. Deflection Testing:
1. Flexible pipe, including "semi-rigid" pipe, is required to show no more than 5 percent deflection.
 2. Test pipe no sooner than 30 days after backfilling of a line segment but prior to final acceptance using a standard mandrel to verify that installed pipe is within specified deflection tolerances.
 3. The manufacturers' specification sheet listing O.D. of the mandrel shall be submitted to the Village Engineer or qualified Village Agent for review before testing is initiated.
 4. Mandrel Sizing:
 - a. The rigid mandrel shall have an outside diameter (O.D.) equal to 95 percent of the inside diameter (I.D.) of the pipe.
 - b. The inside diameter of the pipe, for the purpose of determining the outside diameter of the mandrel, shall be the average outside diameter minus two minimum wall thicknesses for O.D. controlled pipe and the average inside diameter for I.D. controlled pipe.
 5. Mandrel Design:
 - a. The rigid mandrel shall be constructed of a metal or a rigid plastic material that can withstand 200 psi without being deformed.
 - b. The mandrel shall have nine or more "runners" or "legs" as long as the total number of legs is an odd number.
 - c. The barrel section of the mandrel shall have a length of at least 75 percent of the inside diameter of the pipe.
 - d. The rigid mandrel shall not have adjustable or collapsible legs which would allow reduction in mandrel diameter during testing.
 - e. The mandrel shall be marked on the fins indicating that it is for use with PVC pipe.
 6. The mandrel shall be drawn by hand through the pipe from manhole-to-manhole.
 7. Any portion of pipe through which the mandrel passes freely shall be deemed to have passed the deflection test.
 8. Sections of pipe through which the mandrel does not pass shall be located, uncovered, and the pipe re-laid or replaced as required by the Village Engineer or qualified Village Agent. Use PVC repair couplers.
 9. Perform deflection testing in accordance with ASTM D3034 (4-15 inch pipe) and ASTM F679 (18-36 inch pipe).

E. Infiltration Testing:

1. An infiltration test may be required by the Village Engineer or qualified Village Agent.
2. The total infiltration shall not exceed 200 gallons per inch diameter per mile of pipe per 24 hours.
3. Total infiltration shall be reduced to 40 gallons per inch of inside diameter per mile per 24 hours, when sewer is identified as located within the 25-year floodplain.
4. Test Equipment:
 - a. Pipe plugs
5. Procedure:
 - a. Plug incoming pipes in upstream manhole.
 - b. Measure the volume of water in the downstream manhole (1 inch of water in 4 foot diameter manhole equals 7.83 gallons).
 - c. The volume must not exceed that calculated for 2 hours by the formula above.

F. Exfiltration Testing:

1. An exfiltration test may be required by the Village Engineer or qualified Village Agent.
2. The total exfiltration, as determined by a hydrostatic head test, shall not exceed 200 gallons per inch diameter per mile of pipe per 24 hours at a minimum test head of 2 feet above the crown of the pipe at the upstream manhole or 2 feet above the groundwater elevation, whichever is greater.
3. Total exfiltration shall be reduced to 40 gallons per inch of inside diameter per mile per 24 hours, when sewer is identified as located within the 25-year floodplain.
4. Test Equipment:
 - a. Pipe plugs.
 - b. Pipe risers where the manhole cone is less than 2 feet above highest point in pipe or service lead.
5. Procedure:
 - a. Determine ground water elevation.
 - b. Plug sewer in downstream manhole.
 - c. Plug incoming pipes in upstream manhole.
 - d. Install riser pipe in outgoing pipe of upstream manhole if highest point in service lead (house service) is less than 2 feet below bottom of manhole cone.
 - e. Fill sewer pipe and manhole or pipe riser, if used, with water to a point 2-1/2 feet above highest point in sewer pipe, house lead, or ground water table, whichever is highest.
 - f. After the sewer has been filled with water, allow 2 hours time for water absorption by the pipe before exfiltration tests are initiated.
 - g. Take water level reading to determine drop of water surface, in inches over a one-hour period, and calculate water loss (1 inch of water in 4 foot diameter manhole equals 7.83 gallons) or measure the quantity of water required to keep water at the same level.
 - h. Loss shall not exceed that calculated by the formula above.

3.08 FIELD QUALITY CONTROL - WATER MAINS, FORCE MAINS, AND PRESSURIZED PIPE

- A. Perform acceptance testing in accordance with manufacturer's instructions and the following:

1. Test all parts of piping systems using clean water and hydrostatic pressure and leakage tests, unless otherwise indicated.
2. Underground Piping:
 - a. Test after partial completion of backfill but before full completion of backfill; leave joints exposed for examination.
 - b. Exception: Where concrete thrust blocking is provided in special circumstances, do not test that section of piping until at least 5 days after installation of concrete, unless otherwise approved by the Village Engineer or qualified Village Agent.
 - c. This requirement for joints to remain exposed for hydrostatic testing may be waived by Village Engineer or qualified Village Agent when one or more of following conditions are encountered; request waiver in writing with reasons and alternative procedure to accomplish equivalent testing.
 - 1) Wet or unstable soil conditions in the trench.
 - 2) Compliance would require maintaining barricades and walkways around and across an open trench in a heavily used area that would require continuous surveillance to ensure safe conditions.
 - 3) Maintaining trench in open condition would delay completion.
3. Above Ground Piping:
 - a. Test after piping has been completely installed, including all supports, hangers, and anchors, and inspected for proper installation but prior to installation of insulation, if any.
4. Testing New to Existing Connections:
 - a. Isolate new Work with pipe caps, blind flanges, or other effective methods.
 - b. Test the joint between new and existing Work by methods that do not place entire existing system under test load.
5. Hydrant Testing:
 - a. Each hydrant assembly shall be tested by the Contractor.
 - 1) Start by opening operating nut and check for leaks throughout the hydrant while checking the ease of operation of the hydrant.
 - 2) Close the 6" hydrant branch valve off and then open hydrant operating nut all the way. Release any pressure by SLOWLY removing the nozzle cap that you will use for flushing; Listen for any noise of water running; this will test the branch valve.
 - 3) Furnish the necessary hoses for disposal of flushing water. Open cap and screw on a hose or diffuser to the hydrant. Throttle the flow by using the 6" branch valve by opening slowly to get the most flow while considering your surroundings. Run for at least 10 minutes.
 - 4) Turn off hydrant using the operating nut; Do not over tighten. Remove hose or diffuser. Check for leaks; visually see that water does not continue to drip out of nozzle and also listen for water hissing. This will test the shoe valve at bottom of hydrant.
 - 5) Ensure hydrant operating nut is closed (do not over tighten); pump out hydrant. Apply food grade grease on the nozzle threads and return caps and tighten. Make sure that the Branch valve is all the way opened before leaving.
 - b. A testing schedule and method of disposing of flushing water shall be submitted to Village Engineer or qualified Village Agent for approval. The Contractor shall coordinate the testing schedule with Village Engineer or qualified Village Agent.

B. Perform hydrostatic and leakage testing in accordance with the following:

1. Ductile Iron: Comply with AWWA C600.

2. PVC/PVCO/Fusible PVC (C900, C905, C909): Comply with AWWA C605.
 - a. Fusible PVC: Visit the following link for additional detail.
www.undergroundolutions.com/pvc-pressure-testing.php. Allowable leakage on all heat fusion welded sections shall be zero.
 3. HDPE: Comply with ASTM F2164.
- C. Meters and Backflow preventers shall be installed on connections to potable water supply during acceptance testing activities.
 - D. Maximum Velocity During Filling: 0.25 fps applied over full area of pipe or as recommended by pipe manufacturer, whichever is lesser.
 - E. Venting Air While Filling: Purge all air in system; open air release vents to purge air pockets; venting may also be provided by loosening minimum of four bolts of flanges or by use of equipment vents.
 - F. Valves: Include each valve in at least one piping section tested; open and close valves several times during test.
 - G. Inspect pipe, fittings, joints and connections, and valves for visible leakage; correct leaks and re-test until results are satisfactory.

END OF SECTION

SECTION 33 09 01.01
WATERMAIN PRESSURE TEST

PART 1

1.01 PIPE DATA:

A. Location: _____ Date: _____

B. Maximum Permitted Leakage

C. Length: _____ Size: _____ Hour: _____

D. Test:

	Start	End	Elapsed Time
Time:	_____	_____	_____
Pressure:	_____	_____	_____

E. The section of pipe to be tested shall hold the test pressure with no more than a 5% loss in pressure over the test period or the leakage per both under the conditions of the test shall not exceed values determined by the following equation.

Pressure Before Adding Water	Time Added	Amount of Water Added	Pressure After Adding Water	Comments

F. Total Water Added: _____ L= SD P/133,200

G. Actual Leakage/Hr: _____ = Total Water Added/Elapsed Time

H. Approved By: _____

I. Signed: _____

1. L = Allowable leakage per hour (gallons)
2. S = Length of pipe in test (feet)
3. D = Nominal diameter of pipe (inches)
4. P = Average test pressure (psi, gauge)

END OF SECTION

SECTION 33 13 00

DISINFECTING OF WATER UTILITY DISTRIBUTION

PART 1 GENERAL

1.01 SECTION INCLUDES

- A. Disinfection of municipal water lines and appurtenances specified in Section 33 14 16.

1.02 RELATED REQUIREMENTS

- A. Section 33 14 16 - Water Piping.

1.03 REFERENCE STANDARDS

- A. AWWA C651 - Disinfecting Water Mains; 2014.

1.04 SUBMITTALS

- A. See Section 01 30 00 - Administrative Requirements, for submittal procedures.
- B. Disinfection report:
 - 1. Type and form of disinfectant used.
 - 2. Date and time of disinfectant injection start and time of completion.
 - 3. Test locations.
 - 4. Initial and 24 hour disinfectant residuals (quantity in treated water) in ppm for each outlet tested.
 - 5. Date and time of flushing start and completion.
 - 6. Disinfectant residual after flushing in ppm for each outlet tested.

PART 2 PRODUCTS

2.01 DISINFECTION CHEMICALS

- A. Chemicals: Chemicals allowed under the latest edition of AWWA C651.

PART 3 EXECUTION

3.01 EXAMINATION

- A. Verify that piping system has been cleaned, inspected, and pressure tested.
- B. Schedule disinfecting activity to coordinate with start-up, testing, adjusting and balancing, demonstration procedures, including related systems.

3.02 DISINFECTION

- A. Use method prescribed by AWWA C651.

3.03 FIELD QUALITY CONTROL

- A. Test samples in accordance with AWWA C651.

END OF SECTION

SECTION 33 14 16

WATER PIPING

PART 1 GENERAL

1.01 SECTION INCLUDES

- A. Fire hydrants.
- B. Pipe and fittings for Site water lines including municipal water main and service lines.
- C. Valves and Domestic water hydrants.

1.02 RELATED REQUIREMENTS

- A. Section 33 05 13 - Manholes and Structures.
- B. Section 33 07 00 - Directional Drilling.
- C. Section 33 09 01 - Installation and Acceptance Testing of Pipe and Accessories.
- D. Section 33 13 00 - Disinfecting of Water Utility Distribution: Disinfection of Site service utility water piping.

1.03 REFERENCE STANDARDS

- A. ASME B16.1 - Gray Iron Pipe Flanges and Flanged Fittings: Classes 25, 125, and 250; 2010.
- B. ASME B16.18 - Cast Copper Alloy Solder Joint Pressure Fittings; 2012.
- C. ASME B16.22 - Wrought Copper and Copper Alloy Solder-Joint Pressure Fittings; 2013.
- D. ASTM B88 - Standard Specification for Seamless Copper Water Tube; 2016.
- E. ASTM D3035 - Standard Specification for Polyethylene (PE) Plastic Pipe (DR-PR) Based on Controlled Outside Diameter; 2015.
- F. ASTM D3139 - Standard Specification for Joints for Plastic Pressure Pipes using Flexible Elastomeric Seals; 1998 (Reapproved 2011).
- G. ASTM D3350 - Standard Specification for Polyethylene Plastics Pipe and Fittings Material; 2014.
- H. ASTM F2620 - Standard Practice for Heat Fusion Joining of Polyethylene Pipe and Fittings; 2013.
- I. ASTM F477 - Standard Specification for Elastomeric Seals (Gaskets) for Joining Plastic Pipe; 2014.
- J. AWS A5.8M/A5.8 - Specification for Filler Metals for Brazing and Braze Welding; 2011-AMD 1.
- K. AWWA C104/A21.4 - Cement-Mortar Lining for Ductile-Iron Pipe and Fittings for Water; 2013.
- L. AWWA C105/A21.5 - Polyethylene Encasement for Ductile-Iron Pipe Systems; 2010.
- M. AWWA C110/A21.10 - Ductile-Iron and Gray-Iron Fittings; 2012.
- N. AWWA C111/A21.11 - Rubber-Gasket Joints for Ductile-Iron Pressure Pipe and Fittings; 2017.
- O. AWWA C115/A21.15 - Flanged Ductile-Iron Pipe with Ductile-Iron or Gray-Iron Threaded Flanges; 2011.
- P. AWWA C116/A21.16 - Protective Fusion-Bonded Coatings for the Interior and Exterior Surfaces of Ductile-Iron and Gray-Iron Fittings; 2015.

- Q. AWWA C150/A21.50 - Thickness Design of Ductile-Iron Pipe; 2014.
- R. AWWA C151/A21.51 - Ductile-Iron Pipe, Centrifugally Cast; 2009.
- S. AWWA C207 - Steel Pipe Flanges for Waterworks Service, Size 4 In. Through 144 In. (100 mm Through 3,600 mm); 2007.
- T. AWWA C502 - Dry-Barrel Fire Hydrants; 2014.
- U. AWWA C550 - Protective Interior Coatings for Valves and Hydrants; 2013.
- V. AWWA C900 - Polyvinyl Chloride (PVC) Pressure Pipe, 4 In. Through 12 In. (100 mm Through 300 mm), for Water Transmission and Distribution; 2016.
- W. AWWA C905 - AWWA C905-97 Polyvinyl Chloride (PVC) Pressure Pipe and Fabricated Fittings, 14 in. Through 48 in. (350 mm through 1,200 mm), for Water Transmission and Distribution; 1998.
- X. AWWA C906 - Polyethylene (PE) Pressure Pipe and Fittings, 4 In. (100 mm) Through 63 In. (1,600 mm), for Waterworks; 2015.
- Y. AWWA C909 - Molecularly Oriented Polyvinyl Chloride (PVCO) Pressure Pipe, 4 In. Through 24 In. (100 mm Through 600 mm) for Water, Wastewater, and Reclaimed Water Service; 2013.
- Z. MSS SP-25 - Standard Marking System for Valves, Fittings, Flanges and Unions; 2013.
- AA. NSF 14 - Plastics Piping System Components and Related Materials; 2012.
- AB. NSF 372 - Drinking Water System Components - Lead Content; 2016.
- AC. NSF 61 - Drinking Water System Components - Health Effects; 2016.
- AD. UL 246 - Hydrants for Fire-Protection Service; Current Edition, Including All Revisions.

1.04 SUBMITTALS

- A. See Section 01 30 00 - Administrative Requirements, for submittal procedures.
- B. Product Data: Provide data on pipe materials, pipe fittings, valves and accessories.
- C. Manufacturer's Certificate: Certify that products meet or exceed specified requirements.
- D. Manufacturer's Installation Instructions:
 - 1. Indicate special procedures required to install Products specified.
 - 2. Should the Contract Documents contradict the manufacturer's recommendations, the Contractor shall notify the Village Engineer or qualified Village Agent and request direction.
- E. Project Record Documents:
 - 1. Record actual locations of piping mains, valves, connections, thrust restraints, and invert elevations.
 - 2. Identify and describe unexpected variations to subsoil conditions or discovery of uncharted utilities.
- F. Spare Quick Connectors.

PART 2 PRODUCTS

2.01 GENERAL:

- A. All pipe, pipe fittings, plumbing fittings, and fixtures that are to be used for potable water must comply with the lead-free requirement and must comply with NSF 61, NSF 61 - Annex G, NSF 14 and/or NSF 372.
- B. Joints shall be push-on type, as approved by Village Engineer or qualified Village Agent.
- C. Joint restraints, where necessary, shall be push-on locking type gaskets. All pipe joints shall be properly restrained to withstand design pressures:
 - 1. Manufacturers:
 - a. Ductile Iron - US Pipe Co.; TR Flex, Field Lok, or Tyton: www.uspipe.com/products.
 - b. PVC - JM Eagle; Eagle Loc 900: www.jmeagle.com/watersewer/eagle-loc-900.
 - c. Substitutions: See Section 01 60 00 - Product Requirements.
- D. Mechanical or flanged joints will be allowed for special applications only, subject to the approval of Village Engineer or qualified Village Agent. Sealing gaskets, retainer glands, joint restraint gaskets and lubricants for joints shall meet pipe manufacturer's specifications. When approved, pipe restraints, restrained flange adapters, restrained couplings and gaskets shall be:
 - 1. Manufacturers:
 - a. EBAA Iron Inc: www.ebaa.com/products/overview/.
 - b. Substitutions: See Section 01 60 00 - Product Requirements.
- E. Fittings for PVC pipe shall be mechanical.

2.02 WATER MAIN PIPE MATERIALS

- A. Provide products that comply with applicable code(s).
- B. Ductile Iron Pipe: AWWA C151/A21.51, AWWA C150/A21.50, Class 54 unless otherwise indicated on Drawings:
 - 1. Cement-Mortar Lining: AWWA C104/A21.4.
 - 2. Fittings: Ductile iron, match pipe class, Class 54 minimum.
 - a. Flanged: AWWA C115/A21.15
 - b. Non-flanged: AWWA C110/A21.10
 - 3. Joints: AWWA C111/A21.11.
- C. Copper Tubing: ASTM B88, Type K, annealed:
 - 1. Fittings: ASME B16.18, cast copper, or ASME B16.22, wrought copper.
 - 2. Joints: Compression connection or AWS A5.8M/A5.8, BCuP silver braze.
- D. PVC and Fusible PVC Pipe: AWWA C900/AWWA C905, Dimension Ratio DR18 (235 psi) unless otherwise indicated on Drawings:
 - 1. Fittings: AWWA C111/A21.11, .
 - 2. Joints: ASTM D3139, with ASTM F477 gaskets.
- E. PVCO Pipe: AWWA C909, Pressure Class 235 psi, (6"-12") and Pressure Class 165 psi, (16"):

1. Fittings: AWWA C111/A21.11.
 2. Joints: ASTM D3139, with ASTM F477 gaskets.
- F. Polyethylene (HDPE) Pipe: AWWA C906, ASTM D3350 and ASTM D3035, Polyethylene (HDPE) material (DR-PR), minimum pressure rating of 200 psi, at 73.4 degrees F, Ductile Iron Pipe Size (DIPS). Thermal butt fusion joints and fittings in accordance with manufacturer's recommendations; pipe and fittings same material utilizing transition fittings when connecting to existing piping.
1. Joints:
 - a. Heat Fusion Joints: ASTM F2620.
 - b. Mechanical Joints: ASME B16.1.
 - c. Flanged Joints: ASME B16.1 or AWWA C207.
 2. Color: Black with blue striping.

2.03 REQUIREMENTS APPLICABLE TO ALL VALVES

- A. See Drawings for valve sizes and piping types and sizes.
- B. Do not direct-bury flanged valves; provide manhole as indicated on Drawings.
- C. Provide valves suitable for the service indicated and coordinated to piping system.
 1. Provide valves that will withstand working pressure indicated or working pressure of pipe to which valve is connected, whichever is greater.
 2. Provide valves of sizes indicated or of port diameter/area equal to that of pipe to which valve is connected, whichever is larger.
 3. Provide valves that open by turning counterclockwise, with direction of opening integrally marked on operating nut or operator.
 4. Valve End Connections: As indicated; if not indicated, provide end connections of the same type as indicated for joints in pipe to which valve is connected.
 5. Factory install operators and accessories.
- D. Identification and Tagging: Mark exposed valves in accordance with MSS SP-25 using identification tags securely attached; on tags show the service, valve identification number from Drawings or as directed by Village Engineer or qualified Village Agent, manufacturer's name and model number.
 1. Identification Tags: 1 1/2 inches diameter, minimum; engraved laminated plastic or stamped brass with black lettering.
 2. Attachment: No. 12 AWG copper wire.

2.04 REQUIREMENTS APPLICABLE TO METAL-BODY VALVES

- A. Valve End Connections:
 1. Flanged Ends: In accordance with ASME B16.1; Class 125 pound unless otherwise indicated.
 2. Mechanical Joint Ends: Rubber gasketed type, in accordance with AWWA C111/A21.11 and AWWA C110/A21.10.
 3. Push-On Joint Ends: Rubber gasketed type, in accordance with AWWA C110/A21.10 and AWWA C111/A21.11.

- B. Valve Exterior Finish: Factory-applied epoxy coating complying with AWWA C550; either two-part liquid material or heat-activated material.
 - 1. Where valve is indicated to have fusion bonded epoxy finish, provide only heat-activated material conforming to AWWA C116/A21.16.
 - 2. Coating Thickness: 7 mils, minimum, dry film thickness.
- C. Valve Lining: Where valves are indicated to be lined, provide factory-applied lining; use epoxy lining unless other material is indicated.
 - 1. Epoxy Lining: AWWA C550; either two-part liquid material or heat-activated material except provide only heat-activated material complying with AWWA C116/A21.16 when lining is indicated as fusion bonded.
 - 2. Epoxy Lining Thickness: 7 mils, minimum, dry film thickness, except where thickness is limited by valve operating tolerances.

2.05 GATE VALVES

- A. Valves: Manufacturer's name and pressure rating marked on valve body.
- B. Gate Valves 3 Inches and Over:
 - 1. Manufacturers:
 - a. EJ Co.; FlowMaster Series: www.americas.ejco.com .
 - b. US Pipe Valve & Hydrant, LLC; A-USP Series: www.uspvh.com.
 - c. Substitutions: See Section 01 60 00 - Product Requirements.
 - 2. Opening: Counter-clockwise.
 - 3. Valve Manholes: Provide for all valves greater than 12 inch diameter.

2.06 VALVE MANHOLES

- A. Valve manholes are specified in Section 33 05 13.

2.07 VALVE BOXES

- A. Manufacturers:
 - 1. EJ Co.; 8560#6 Base, 8560 Bottom, 8550 Top, 6800 Cover: www.americas.ejco.com.
 - 2. Substitutions: See Section 01 60 00 - Product Requirements.
- B. Application: Provide for all valves from 3 inch to 12 inch diameter.

2.08 HYDRANTS

- A. Hydrants: AWWA C502, UL 246, dry barrel type.
 - 1. Manufacturers:
 - a. EJ Co.; 5BR 250-54913D (Village of Pinckney): www.americas.ejco.com.
 - b. US Pipe Valve & Hydrant, LLC; Metropolitan M-94: www.uspvh.com/products/fire-hydrants-us-pipe/hydrants/metropolitan-m-94/.
 - c. Substitutions: See Section 01 60 00 - Product Requirements.
 - 2. Breakaway Safe: Yes.

3. Opening: Counter-clockwise.
4. Operating Nut: 1 1/8 inch cast iron pentagon.
5. Valve Opening: 5 1/4 inch.
6. Inlet: 6 inch diameter.
7. Drain Holes: 2 with removable brass plugs.
8. Bury Depth: 5 1/2 feet cover over pipe (extensions may be needed).
9. Hydrant Shoe: Push-on locking gasket type.
10. Hose Connection(s): Two - 2 1/2 inch, National Standard Thread.
11. Pumper Connection(s): One - 4 1/2 inch, National Standard Thread.
12. Finish:
 - a. Factory finish in color selected by Owner.
 - b. Special colors, if required by Owner, shall be field painted with a paint system specified by Engineer.
13. Quick Connector:
 - a. Manufacturers:
 - 1) Harrington, Inc.; Storz 5 inch Permanent Hydrant Adapter with Cap:
www.harrinc.com/shop/storz-permanent-hydrant-adapters-with-cap/.
 - 2) Substitutions: See Section 01 60 00 - Product Requirements.
 - b. Quantity: One for each Pumper Connection and 1 spare(s) of each size on Project.

2.09 MISCELLANEOUS MATERIALS AND ACCESSORIES

- A. Joint lubricants: As recommended by the pipe manufacturer.
- B. Bolts, Nuts, Rods, Brackets, and Glands: Comply with AWWA C111/A21.11.
- C. Polyethylene Jackets: AWWA C105/A21.5 polyethylene jacket where indicated on Drawings for certain ductile iron pipe applications. Single layer, lapped over pipe joint 1 foot minimum, and secured with 10 mil polyethylene tape.
- D. Water Services:
 1. 1 inch Service:
 - a. Corporation Valve - Mueller Ground Key 1"-H-15008N CCxCTS
 - b. Curb Valve - Mueller Mark II Oriseal 1"-H-15209N CTSxCTS
 - c. Curb Valve Box - Mueller Extension Type, Arch pattern base H-10314 66", Stationary Rod 82866
 - d. Union Coupling - Mueller Straight 3 Part Union 1"-H-15403N CTSxCTS
 - e. Backflow Preventer for Irrigation Lines - as approved by the Village Engineer or qualified Village Agent.
 2. 1 1/2 inch Service:
 - a. Corporation Valve - Mueller Ground Key 1 1/2"-H-15008N CCxCTS
 - b. Curb Valve - Mueller Mark II Oriseal 1 1/2"-H-15209N CTSxCTS
 - c. Curb Valve Box - Mueller Extension Type, Arch pattern base H-10308 66", Stationary Rod 84353
 - d. Union Coupling - Mueller Straight 3 Part Union 1 1/2"-H-15403N CTSxCTS

- e. Backflow Preventer for Irrigation Lines - as approved by the Village Engineer or qualified Village Agent.
- 3. 2 inch Service:
 - a. Corporation Valve - Mueller Ground Key 2"-H-15008N CCxCTS
 - b. Curb Valve - Mueller Mark II Oriseal 2"-H-15209N CTSxCTS
 - c. Curb Valve Box - Mueller Extension Type, Arch pattern base H-10310 66", Stationary Rod 84140
 - d. Union Coupling - Mueller Straight 3 Part Union 2"-H-15403N CTSxCTS
 - e. Backflow Preventer for Irrigation Lines - as approved by the Village Engineer or qualified Village Agent.
- 4. Meters
 - a. Meters shall be as directed by the Village Engineer or qualified Village Agent.
 - b. Homeowner or Proprietor shall be responsible for meter installation.
 - c. DPW to inspect meter installation and connect Radioread meter transceiver unit prior to turning on water to the building.
- 5. Pipe:
 - a. Use copper tubing conforming to ASTM B88ASTM B88, Type K, annealed from the corporation valve to the curb valve.
 - b. Use copper tubing conforming to ASTM B88ASTM B88, Type K, annealed or Endot Endopure SDR9 Blue CTS water service tubing from the curb valve to the building.
- 6. Saddles:
 - a. Saddles (when required) will be as directed by the Village Engineer or qualified Village Agent.

PART 3 EXECUTION

3.01 INSTALLATION AND FIELD QUALITY CONTROL

- A. Perform Work in accordance with Section 33 09 01.

END OF SECTION

SECTION 33 31 13
SANITARY SEWER PIPING

PART 1 GENERAL

1.01 SECTION INCLUDES

- A. Sanitary sewer gravity piping, fittings, and accessories.
- B. Connection of stubs and service leads to municipal sewers.

1.02 RELATED REQUIREMENTS

- A. Section 31 23 16.13 - Trenching: Excavating, bedding, and backfilling.
- B. Section 33 05 13 - Manholes and Structures.
- C. Section 33 06 00 - Trace Wire and Locator Tape.
- D. Section 33 09 01 - Installation and Acceptance Testing of Pipe and Accessories.

1.03 REFERENCE STANDARDS

- A. ASTM D3034 - Standard Specification for Type PSM Poly(Vinyl Chloride) (PVC) Sewer Pipe and Fittings; 2016.
- B. ASTM D3212 - Standard Specification for Joints for Drain and Sewer Plastic Pipes Using Flexible Elastomeric Seals; 2013.
- C. ASTM F477 - Standard Specification for Elastomeric Seals (Gaskets) for Joining Plastic Pipe; 2014.

1.04 SUBMITTALS

- A. See Section 01 30 00 - Administrative Requirements, for submittal procedures.
- B. Product Data: Provide data indicating pipe materials, pipe fittings and accessories.
- C. Manufacturer's Certificate: Certify that products meet or exceed specified requirements.
- D. Manufacturer's Installation Instructions:
 - 1. Indicate special procedures required to install Products specified.
 - 2. The maximum depth to invert of any sanitary sewer shall not exceed the depth recommended by the manufacturer for each size and class of pipe.
 - 3. Should the Contract Documents contradict the manufacturer's recommendations, the Contractor shall notify the Village Engineer or qualified Village Agent and request direction.
- E. Project Record Documents:
 - 1. Record actual location of pipe runs, connections, manholes, cleanouts, stubs, service leads, and invert elevations.
 - 2. Identify and describe unexpected variations to subsoil conditions or discovery of uncharted utilities.

PART 2 PRODUCTS

2.01 GENERAL:

- A. Joints shall be push-on type, as approved by Village Engineer or qualified Village Agent.

2.02 SANITARY SEWER PIPE MATERIALS

- A. Provide products that comply with applicable code(s).
- B. PVC Pipe: ASTM D3034 Standard Dimension Ratio SDR 26 unless otherwise indicated on Drawings:
 - 1. Fittings: ASTM D3034.
 - 2. Joints: ASTM D3212, with ASTM F477 gaskets.

2.03 MISCELLANEOUS MATERIALS AND ACCESSORIES

- A. Joint lubricants: As recommended by the pipe manufacturer.
- B. Clay Pipe Tapping Saddles:
 - 1. Manufacturers:
 - a. Romac Industries, Inc.; CB Saddle: www.romac.com/cb-sewer
 - b. Substitutions: See Section 01 60 00 - Product Requirements.

PART 3 EXECUTION

3.01 INSTALLATION AND FIELD QUALITY CONTROL

- A. Perform Work in accordance with Section 33 09 01.

END OF SECTION

SECTION 33 31 23
SANITARY FORCE MAIN PIPING

PART 1 GENERAL

1.01 SECTION INCLUDES

- A. Sanitary sewerage force main piping, fittings, and accessories.
- B. Valves, Valve Manholes, and Thrust Restraints.

1.02 RELATED REQUIREMENTS

- A. Section 31 23 16.13 - Trenching: Excavating, bedding, and backfilling.
- B. Section 33 05 13 - Manholes and Structures.
- C. Section 33 06 00 - Trace Wire and Locator Tape.
- D. Section 33 07 00 - Directional Drilling.
- E. Section 33 09 01 - Installation and Acceptance Testing of Pipe and Accessories.

1.03 SUBMITTALS

- A. See Section 01 30 00 - Administrative Requirements, for submittal procedures.
- B. Product Data: Provide data indicating pipe materials, pipe fittings, valves and accessories.
- C. Manufacturer's Certificate: Certify that products meet or exceed specified requirements.
- D. Manufacturer's Installation Instructions:
 - 1. Indicate special procedures required to install Products specified.
 - 2. Should the Contract Documents contradict the manufacturer's recommendations, the Contractor shall notify the Engineer and request direction.
- E. Project Record Documents:
 - 1. Record actual locations of piping mains, valves, connections, thrust restraints, and invert elevations .
 - 2. Identify and describe unexpected variations to subsoil conditions or discovery of uncharted utilities.

PART 2 PRODUCTS

2.01 GENERAL:

- A. Joints shall be push-on type, as approved by Village Engineer or qualified Village Agent.
- B. Joint restraints, where necessary, shall be push-on locking type gaskets. All pipe joints within 40 feet of a fitting shall be restrained:
 - 1. Manufacturers:
 - a. Ductile Iron - US Pipe Co.; TR Flex, Field Lok, or Tyton: www.uspipe.com/products.
 - b. PVC - JM Eagle Eagle Loc 900: www.jmeagle.com/watersewer/eagle-loc-900.
 - c. Substitutions: See Section 01 60 00 - Product Requirements.

- C. Mechanical or flanged joints will be allowed for special applications only, subject to the approval of Engineer. Sealing gaskets, retainer glands, joint restraint gaskets and lubricants for joints shall meet pipe manufacturer's specifications. When approved, pipe restraints, restrained flange adapters, restrained couplings and gaskets shall be:
 - 1. Manufacturers:
 - a. EBAA Iron Inc: www.ebaa.com/products/overview/.
 - b. Substitutions: See Section 01 60 00 - Product Requirements.
- D. Fittings for PVC pipe shall be push-on locking type gaskets.
 - 1. Manufacturers:
 - a. RCT, LLC Flex-Tite: www.rctfittings.com/products/index.php.
 - b. Substitutions: See Section 01 60 00 - Product Requirements.

2.02 FORCE MAIN PIPE MATERIALS

- A. Provide products that comply with applicable code(s).
- B. Ductile Iron Pipe: AWWA C151/A21.51, AWWA C150/A21.50, Class 53 (Class 54 for river crossings) unless otherwise indicated on Drawings:
 - 1. Cement-Mortar Lining: AWWA C104/A21.4.
 - 2. Fittings: Ductile iron, match pipe class, Class 53 minimum.
 - a. Flanged: AWWA C115/A21.15
 - b. Non-flanged: AWWA C110/A21.10
 - 3. Joints: AWWA C111/A21.11.
- C. PVC and Fusible PVC Pipe: AWWA C900/AWWA C905, Dimension Ratio DR18 (235 psi) unless otherwise indicated on Drawings:
 - 1. Fittings: AWWA C111/A21.11.
 - 2. Joints: ASTM D3139, with ASTM F477 gaskets.
 - 3. Color: green.
- D. PVC Pipe: AWWA C909, Pressure Class 235 psi, (6"-12") and Pressure Class 165 psi, (16"):
 - 1. Fittings: AWWA C111/A21.11.
 - 2. Joints: ASTM D3139, with ASTM F477 gaskets.
 - 3. Color: green.
- E. Polyethylene (HDPE) Pipe: AWWA C906, ASTM D3350 and ASTM D3035, Polyethylene (HDPE) material (DR-PR), minimum pressure rating of 200 psi, at 73.4 degrees F, Ductile Iron Pipe Size (DIPS). Thermal butt fusion joints and fittings in accordance with manufacturer's recommendations; pipe and fittings same material utilizing transition fittings when connecting to existing piping.
 - 1. Joints:
 - a. Heat Fusion Joints: ASTM F2620.
 - b. Mechanical Joints: ASME B16.1.
 - c. Flanged Joints: ASME B16.1 or AWWA C207.

2. Color: Black with green striping.

2.03 REQUIREMENTS APPLICABLE TO ALL VALVES

- A. See Drawings for valve sizes and piping types and sizes.
- B. Do not direct-bury flanged valves; provide valve vault or manhole as indicated on Drawings.
- C. Provide valves suitable for the service indicated and coordinated to piping system.
 1. Provide valves that will withstand working pressure indicated or working pressure of pipe to which valve is connected, whichever is greater.
 2. Provide valves of sizes indicated or of port diameter/area equal to that of pipe to which valve is connected, whichever is larger.
 3. Provide valves that open by turning counterclockwise, with direction of opening integrally marked on operating nut or operator.
 4. Valve End Connections: As indicated; if not indicated, provide end connections of the same type as indicated for joints in pipe to which valve is connected.
 5. Factory install operators and accessories.
- D. Identification and Tagging: Mark exposed valves in accordance with MSS SP-25 using identification tags securely attached; on tags show the service, valve identification number from Drawings or as directed by Engineer, manufacturer's name and model number.
 1. Identification Tags: 1 1/2 inches diameter, minimum; engraved laminated plastic or stamped brass with black lettering.
 2. Attachment: No. 12 AWG copper wire.

2.04 REQUIREMENTS APPLICABLE TO METAL-BODY VALVES

- A. Valve End Connections:
 1. Flanged Ends: In accordance with ASME B16.1; Class 125 pound unless otherwise indicated.
 2. Mechanical Joint Ends: Rubber gasketed type, in accordance with AWWA C111/A21.11 and AWWA C110/A21.10.
 3. Push-On Joint Ends: Rubber gasketed type, in accordance with AWWA C110/A21.10 and AWWA C111/A21.11.
- B. Valve Exterior Finish: Factory-applied epoxy coating complying with AWWA C550; either two-part liquid material or heat-activated material.
 1. Where valve is indicated to have fusion bonded epoxy finish, provide only heat-activated material conforming to AWWA C116/A21.16.
 2. Coating Thickness: 7 mils, minimum, dry film thickness.
- C. Valve Lining: Where valves are indicated to be lined, provide factory-applied lining; use epoxy lining unless other material is indicated.
 1. Epoxy Lining: AWWA C550; either two-part liquid material or heat-activated material except provide only heat-activated material complying with AWWA C116/A21.16 when lining is indicated as fusion bonded.
 2. Epoxy Lining Thickness: 7 mils, minimum, dry film thickness, except where thickness is limited by valve operating tolerances.

2.05 PLUG VALVES

- A. Manufacturers:
 - 1. Val-Matic Valve & Manufacturing Corporation; Cam-Centric: www.valmatic.com.
 - 2. Substitutions: See Section 01 60 00 - Product Requirements.
- B. Plug Valves - Sizes 4 inches through 60 inch: Eccentric type.
 - 1. Rating: 175 psig at 140 degrees F.
 - 2. Cast Iron Valves: Comply with MSS SP-78 and ASTM A126 Class B .
 - 3. Body: Nonlubricated type; cast iron; drip-tight shutoff with pressure from either direction.
 - 4. Plugs: Ductile iron complying with ASTM A536 Grade 65-45-12.
 - 5. Ports: Open area minimum 100 percent of connecting pipe area.
 - 6. Lining (Interior and Exterior): Coated with fusion bonded epoxy conforming to AWWA C116/A21.16.
 - 7. Seats: Nickel.
 - 8. Stem Bearings: Self-lubricating 316 stainless steel.
 - 9. Stem Seals: V-Type packing.
 - 10. End Connections Exposed: Flanged.
 - 11. End Connections Buried: Push-on Locking gasket or mechanical joint.
 - 12. Manual Operator for Valves 6 inches and Smaller: Wrench lever or geared for buried service.
 - 13. Manual Operator for Valves 8 inches and Larger: Geared; with hand wheel, 2-inch nut, or chain wheel. Actuators for submerged or buried service shall be packed with grease and sealed. Plant service gears shall include inspection port so packing is able to be adjusted or replaced without removing the gear.
 - 14. Valve Manholes: Provide for all valves greater than 12 inch diameter.

2.06 AIR RELEASE VALVES

- A. Manufacturers:
 - 1. Val-Matic Valve & Manufacturing Corporation; 802ADISV: www.valmatic.com.
 - 2. Substitutions: See Section 01 60 00 - Product Requirements.
- B. Combination Air Valve Suitable for Corrosive Service: Combined air and vacuum valve and air release valve.
 - 1. Function: Automatically exhaust air during filling of a piping system and allow air to re-enter during draining or when vacuum occurs; automatically exhaust entrained air that accumulates in piping system.
 - 2. Rating: 150 psig working pressure.
 - 3. Body: Ductile iron standard elongated body and cover.
 - 4. Trim and Float: Stainless steel.
 - 5. End Connections:
 - a. Sizes 1/2 through 4 inches: Threaded inlet and outlet, ASME B1.20.1 (ASME B1.20.2M) threading.

6. Provide blow off valve, quick disconnect couplings, and minimum 2 feet of hose to permit back flushing after installation without dismantling valve.
 7. Where valve is indicated to have fusion bonded epoxy finish, provide only heat-activated material conforming to AWWA C116/A21.16.
- C. Isolation Ball Valves: Provide Boshart Industries SSBV304 Series stainless steel ball valves to isolate air release valves for maintenance.
- D. Valve Manholes: Provide for all air release valves.

2.07 VALVE MANHOLES

- A. Valve manholes: As specified in Section 33 05 13.

2.08 VALVE BOXES

- A. Manufacturers:
1. EJ Co.; Model 6800, 8560, 8550#6 3-piece box: www.americas.ejco.com .
 2. Substitutions: See Section 01 60 00 - Product Requirements.
- B. Application: Provide for all valves from 3 inch to 12 inch diameter.

2.09 MISCELLANEOUS MATERIALS AND ACCESSORIES

- A. Joint lubricants: As recommended by the pipe manufacturer.
- B. Bolts, Nuts, Rods, Brackets, and Glands: Comply with AWWA C111/A21.11.
- C. Polyethylene Jackets: AWWA C105/A21.5 polyethylene jacket where indicated on Drawings for certain ductile iron pipe applications. Single layer, lapped over pipe joint 1 foot minimum, and secured with 10 mil polyethylene tape.

PART 3 EXECUTION

3.01 INSTALLATION AND FIELD QUALITY CONTROL

- A. Perform Work in accordance with Section 33 09 01.

END OF SECTION

SECTION 33 32 13
PACKAGED WASTEWATER PUMPING STATIONS

PART 1 GENERAL

1.01 SECTION INCLUDES

- A. Pre-engineered, prefabricated assemblies comprising pump(s), valve(s), internal piping, and controls.
- B. Wet well construction.

1.02 REFERENCE STANDARDS

- A. ASTM C478 - Standard Specification for Circular Precast Reinforced Concrete Manhole Sections; 2015a.

1.03 SUBMITTALS

- A. See Section 01 30 00 - Administrative Requirements, for submittal procedures.
- B. Product Data: Manufacturer's technical literature for prefabricated assemblies and pump chamber and access way; include installation instructions.
 - 1. Control and power instrumentation and panels.
 - 2. Pump curves.
 - 3. Motor data.
 - 4. Specimen warranty.
- C. Shop Drawings: Detailed drawings of entire pumping station, combining components furnished by different manufacturers, if any.
 - 1. Control panel schematic diagrams.
 - 2. Show the design of the chamber, with dimensions, types, and thicknesses of materials, and elevation levels with reference to those elevations indicated.
- D. Operating and Maintenance Data:
 - 1. Submit preventative maintenance and inspection procedure for package lift stations.
 - 2. Include in procedures the frequency of preventative maintenance, inspection, adjustment, lubrication, and cleaning necessary to minimize corrective maintenance and repair.
 - 3. Submit spare parts data, including a complete list of parts and supplies with current unit prices and source of supply.
 - 4. List parts and supplies that are either normally furnished at no extra cost with the purchase of equipment, or specified to be furnished as a part of the contract, and list additional items recommended by the manufacturer to ensure an efficient operation for a period of one year.
- E. Maintenance Materials:
 - 1. One set of special tools that are required for maintenance and testing.
- F. Executed Warranty.

1.04 WARRANTY

- A. Warranty: Provide manufacturer's warranty for packaged pump station, with itemized list of components covered by warranty; include list of specific operation and maintenance procedures that are required to keep warranty valid.

PART 2 PRODUCTS

2.01 MANUFACTURERS

- A. Packaged Wastewater Pumping Station:
 - 1. Gorman Rupp: www.grpumps.com.
 - 2. Substitutions: See Section 01 60 00 - Product Requirements.

2.02 PACKAGED WASTEWATER PUMPING STATIONS

- A. Packaged Wastewater Pumping Stations: Pre-engineered duplex sewage pump station, including wet well/pump chamber construction, access way(s), valves, internal piping, internal wiring, controls, and other necessary components for continuous, unattended, automatic operation.
 - 1. Furnish all components factory-assembled; where field installation is required, provide piping, wiring, and other components as required for a complete installation.
 - 2. Configuration: Wet well and access way, surface hatch; pumps and controls mounted at grade in weatherproof enclosure provided as part of packaged equipment.
 - 3. Service Life: 20 years.
- B. Anchors and Fasteners: Stainless steel.
- C. Other appurtenances required for construction and approved by the Village Engineer or qualified Village Agent.

2.03 WET WELL AND PUMP CHAMBER CONSTRUCTION

- A. Concrete Construction: Precast concrete sections complying with ASTM C478 (ASTM C478M).
 - 1. Microbiologically-Induced Corrosion-Inhibiting and Waterproofing Admixture.
 - a. Manufacturers:
 - 1) Xypex Chemical Corporation; Bio-San 500: www.xypex.com.
 - 2) Substitutions: See Section 01 60 00 - Product Requirements.

2.04 CONTROL FUNCTIONS AND INSTRUMENTATION

- A. Pump Controls: Provide controls capable of operating pumps either simultaneously or individually, depending on load conditions.
 - 1. Pump Actuator: Submersible pressure type level sensor.

2.05 SOURCE QUALITY CONTROL

- A. Test pump, valve, and piping assembly in factory prior to shipping, at test pressure equal to 50 percent more than pump discharge pressure or total dynamic head, whichever is greater.

PART 3 EXECUTION

3.01 MANUFACTURER FIELD SERVICES

- A. Provide the services of equipment manufacturer's technical representative to direct startup of station and instruct Owner's personnel in startup, operation, and maintenance procedures.

END OF SECTION

SECTION 33 42 11
STORM SEWER PIPING

PART 1 GENERAL

1.01 SECTION INCLUDES

- A. Storm drainage piping, fittings, and accessories.
- B. Connection of drainage system to municipal sewers.

1.02 RELATED REQUIREMENTS

- A. Section 33 09 01 - Installation and Acceptance Testing of Pipe and Accessories.

1.03 REFERENCE STANDARDS

- A. AASHTO M 274 - Standard Specification for Steel Sheet, Aluminum-Coated (Type 2), for Corrugated Steel Pipe; 1987 (Reapproved 2012).
- B. AASHTO M 36 - Standard Specification for Corrugated Steel Pipe, Metallic-Coated, for Sewers and Drains; 2016.
- C. AASHTO M 252 - Standard Specification for Corrugated Polyethylene Drainage Pipe; 2009 (Reapproved 2012).
- D. AASHTO M 294 - Standard Specification for Corrugated Polyethylene Pipe, 300- to 1500 MM (12- to 60-in.) Diameter; 2013.
- E. ASTM C76 - Standard Specification for Reinforced Concrete Culvert, Storm Drain, and Sewer Pipe; 2016.
- F. ASTM C443 - Standard Specification for Joints for Concrete Pipe and Manholes, Using Rubber Gaskets; 2012.
- G. ASTM D3350 - Standard Specification for Polyethylene Plastics Pipe and Fittings Material; 2014.

1.04 SUBMITTALS

- A. See Section 01 30 00 - Administrative Requirements, for submittal procedures.
- B. Product Data: Provide data indicating pipe, pipe fittings pipe accessories.
- C. Manufacturer's Certificate: Certify that products meet or exceed specified requirements.
- D. Manufacturer's Installation Instructions:
 - 1. Indicate special procedures required to install Products specified.
 - 2. The maximum depth to invert of any storm sewer shall not exceed the depth recommended by the manufacturer for each size and class of pipe.
 - 3. Should the contract documents contradict the manufacturer's recommendations, the Contractor shall notify the Village Engineer or qualified Village Agent and request direction.
- E. Project Record Documents:
 - 1. Record actual location of pipe runs, connections, catch basins, cleanouts, and invert elevations.
 - 2. Identify and describe unexpected variations to subsoil conditions or discovery of uncharted utilities.

PART 2 PRODUCTS

2.01 GENERAL

- A. Joints shall be push-on type, as approved by Village Engineer or qualified Village Agent.

2.02 STORM SEWER PIPE MATERIALS

- A. Provide products that comply with applicable code(s).
- B. Concrete Pipe - Sewer Mains: Reinforced, ASTM C76, Class IV, for nominal pipe sizes greater than 10 inches in diameter, unless otherwise indicated on Drawings.
 - 1. Joints: ASTM C443 rubber compression gasket joint.
- C. Corrugated Polyethylene Highway Pipe (Underdrain): ASTM D3350, High Density Polyethylene (HDPE) corrugated wall pipe; inside nominal diameter of 4 or 6 inch, meeting the requirements of AASHTO M 252, Type C or CP, for diameters between 3 inches and 10 inches and AASHTO M 294, Type C or CP, for diameters between 12 inches and 24 inches, soil-tight, manufactured couplings, with pipe and fittings manufactured from virgin PE compounds with cell classification 424420C or 435400C.
- D. Corrugated Steel Pipe - Driveway Culverts: AASHTO M 36 and AASHTO M 274 Type II, Aluminized; nominal diameter of 12 inches minimum, plain end joints; helical lock seam.
 - 1. Coupling Bands: Aluminized steel, 12 inches wide; connected with Buna-N gaskets and galvanized steel bolts.

2.03 MISCELLANEOUS MATERIALS AND ACCESSORIES

- A. Joint lubricants: As recommended by the pipe manufacturer.

PART 3 EXECUTION

3.01 INSTALLATION AND FIELD QUALITY CONTROL

- A. Perform Work in accordance with Section 33 09 01.

END OF SECTION

SECTION 34 01 00

STREET AND OTHER HARD SURFACE IMPROVEMENTS

PART 1 GENERAL

1.01 SECTION INCLUDES

- A. Clearing, removals, roadway earthwork, subbase, aggregate base course, curb and gutter, HMA, concrete sidewalks and drive approaches, and restoration.

1.02 RELATED REQUIREMENTS

- A. Section 31 22 00 - Stripping and Grading: Preparation of Site for paving and base.
- B. Section 31 23 16.13 - Trenching: Structure, pipe and material removal requirements.
- C. Section 33 05 13 - Manholes and Structures.

1.03 REFERENCE STANDARDS

- A. AASHTO M 153 - Standard Specification for Preformed Sponge Rubber and Cork Expansion Joint Fillers for Concrete Paving and Structural Construction; 2006 (Reapproved 2016).
- B. ADA Standards - Americans with Disabilities Act (ADA) Standards for Accessible Design; 2010.
- C. ASTM C173/C173M - Standard Test Method for Air Content of Freshly Mixed Concrete by the Volumetric Method; 2016.
- D. ASTM D1557 - Standard Test Methods for Laboratory Compaction Characteristics of Soil Using Modified Effort (56,000 ft-lbf/ft³ (2,700 kN m/m³)); 2012.
- E. ASTM D1752 - Standard Specification for Preformed Sponge Rubber Cork and Recycled PVC Expansion Joint Fillers for Concrete Paving and Structural Construction; 2004a (Reapproved 2013).
- F. ATBCB PROWAG - Proposed Accessibility Guidelines for Pedestrian Facilities in the Public Right-of-Way; 2011.
- G. MDOT Density Control Handbook - Applicable Sections; 2014.
- H. MDOT Standard Plans R-28 - Sidewalk Ramp and Detectable Warning Details; Latest Edition.
- I. MDOT Standard Plans R-29 - Driveway Openings & Approaches and Concrete Sidewalk; Latest Edition.
- J. MDOT Standard Plans R-30 - Concrete Curb and Concrete Curb & Gutter; Latest Edition.
- K. MDOT Standard Specifications for Construction - Section 205 - Roadway Earthwork; 2012.
- L. MDOT Standard Specifications for Construction - Section 301 - Subbase; 2012.
- M. MDOT Standard Specifications for Construction - Section 302 - Aggregate Base Course; 2012.
- N. MDOT Standard Specifications for Construction - Section 305 - HMA Base Crushing and Shaping; 2012.
- O. MDOT Standard Specifications for Construction - Section 308 - Geotextiles for Base; 2012.
- P. MDOT Standard Specifications for Construction - Section 501 - Plant Produced Hot Mix Asphalt; 2012.
- Q. MDOT Standard Specifications for Construction - Section 501.03.N.1 - HMA Field-Placed Inspection; 2012.
- R. MDOT Standard Specifications for Construction - Section 802 - Concrete Curb, Gutter, and Dividers; 2012.

- S. MDOT Standard Specifications for Construction - Section 803 - Concrete Sidewalks, Sidewalk Ramps, and Steps; 2012.
- T. MDOT Standard Specifications for Construction - Section 812 - Temporary Traffic Control For Construction Zone Operations; 2012.
- U. MDOT Standard Specifications for Construction - Section 901 - Cement and Lime; 2012.
- V. MDOT Standard Specifications for Construction - Section 902 - Aggregates; 2012.
- W. MDOT Standard Specifications for Construction - Section 904 - Asphaltic Materials; 2012.
- X. MDOT Standard Specifications for Construction - Section 906 - Structural Steel; 2012.
- Y. MDOT Standard Specifications for Construction - Section 910 - Geosynthetics; 2012.

1.04 SUBMITTALS

- A. See Section 01 30 00 - Administrative Requirements, for submittal procedures.
- B. Product Data: Provide data on all materials supplied for the project.
- C. Manufacturer's Certificate: Certify that products meet or exceed specified requirements.
- D. Manufacturer's Installation Instructions:
 - 1. Indicate special procedures required to install products specified.
 - 2. Should the Contract Documents contradict the manufacturer's recommendations, the Contractor shall notify the Village Engineer or qualified Village Agent and request direction.
- E. Project Record Documents:
 - 1. Record actual locations referencing station and offset of; subgrade undercut including dimensions and materials used, piping mains, valves, connections, thrust restraints, and structures.
 - 2. Location, size and material of uncharted utilities encountered during excavation using survey grade equipment and locating items in State Plane Coordinate System (SPCS).

PART 2 PRODUCTS

2.01 SUBBASE

- A. Contractor shall furnish Class II granular material in accordance with MDOT Standard Specifications for Construction - Section 902.

2.02 AGGREGATE BASE COURSE

- A. Contractor shall furnish 21 AA aggregate in accordance with MDOT Standard Specifications for Construction - Section 902.

2.03 CONCRETE

- A. Materials:
 - 1. Contractor shall furnish concrete in accordance with MDOT Standard Specifications for Construction - Section 901, MDOT Standard Specifications for Construction - Section 902, and MDOT Standard Specifications for Construction - Section 906 with the following modification(s):
 - a. All concrete shall be MDOT S1 unless otherwise indicated.

- b. Course Aggregate shall be 6AA.
- c. Cement Content shall be 6.5 sack/Cyd (611 lb/Cyd).
- d. Max. Water/Cement Ratio shall be 0.45
- e. Total Air Content: 5.5 - 8.0 percent (no tolerance), determined in accordance with ASTM C173/C173M.
- f. Min. 28 day Compressive Strength shall be 4,000 psi.
- g. Driveway Approaches shall be non-reinforced concrete.
- h. Driveway, Sidewalk, and Sidewalk Ramp expansion material shall be sponge rubber in accordance with ASTM D1752 and AASHTO M 153.

B. Configuration:

- 1. Sidewalk Ramp and Detectable Warning Details:
 - a. In accordance with MDOT Standard Plans R-28, ATBCB PROWAG, ADA Standards, and as indicated on the Drawings with the following modification(s):
 - 1) Sidewalk ramps shall be 6 inches thick unless otherwise indicated on the Drawings.
 - 2) Detectable warning devices shall be EJ Model 7005. Field paint at the direction of the Village Engineer or qualified Village Agent.
- 2. Driveway Opening & Approaches and Concrete Sidewalk:
 - a. In accordance with MDOT Standard Plans R-29, ATBCB PROWAG, ADA Standards, and as indicated on the Drawings with the following modification(s):
 - 1) Concrete Driveway Opening Layout Detail - Tapers and width at sidewalk shall be as directed by the Village Engineer or qualified Village Agent.
 - 2) Concrete Drive Approach Detail - Shall be non-reinforced concrete with a minimum thickness of 10 inches for all drives other than residential. Residential drive approaches and sidewalk shall have a minimum thickness of 6 inches.
 - 3) Thickened Concrete Sidewalk Detail - Extra width requirement adjacent to "W" shall apply to all driveways.
 - 4) Sidewalks shall be 5 feet wide minimum.
- 3. Concrete Curb and Gutter:
 - a. In accordance with MDOT Standard Plans R-30, ATBCB PROWAG, ADA Standards, and as indicated on the Drawings.

2.04 ASPHALT

- A. Contractor shall furnish asphaltic materials in accordance with MDOT Standard Specifications for Construction - Section 904 with the following modification(s):
 - 1. Maximum Recycled Asphalt Pavement (RAP) shall be 20 percent. See Section 01 20 07 - Roadway, Parking, Driveway, and Sidewalk Design Requirements for mix designs.

2.05 GEOTEXTILES FOR BASE

- A. Contractor shall furnish geotextile products for stabilization or separation in accordance with MDOT Standard Specifications for Construction - Section 910.

PART 3 EXECUTION

3.01 MAINTAINING TRAFFIC:

- A. The Contractor shall cooperate in every respect with the local Fire Department, Police Department, and DPW, MDOT, County Road Commission, and the Village Engineer or qualified Village Agent during construction.
- B. The Contractor shall conduct his operation at all times to provide ready access by emergency vehicles to residences and businesses abutting the construction areas.
- C. Every attempt shall be made to provide vehicular access to homes and businesses during construction.
 - 1. Short term interruptions to access shall be coordinated with the Village Engineer or qualified Village Agent and property owners.
 - 2. At the end of each work day, the Contractor shall grade and cleanup the roadway and all private driveways to provide automobile access.
 - 3. During placement of driveways, Contractor shall cooperate with property owners to accommodate alternate parking arrangements.
- D. The Contractor shall be solely responsible for maintaining safe traffic conditions for vehicles and pedestrians at all times.
- E. The Contractor shall coordinate his operations with the local governing agencies having jurisdiction to provide advance notice of the closing of any street.
- F. The Contractor shall furnish, install and maintain traffic control devices in accordance with MDOT Standard Specifications for Construction - Section 812.
 - 1. No Work shall begin on any phase of the project until proper signing has been placed.
- G. The Contractor shall provide 24 hour maintenance of all traffic safety equipment and shall provide telephone numbers of at least two persons for contact in case of emergency.
- H. The Contractor shall not close any street to traffic without prior approval from Village Engineer or qualified Village Agent and notification of all property owners and allowance of sufficient time for evacuation.

3.02 STREET MAINTENANCE:

- A. All streets where construction trucking takes place under this Contract shall at all times be maintained by the Contractor, unless otherwise indicated.
- B. At all times the Contractor shall have available on the project adequate and suitable road maintenance equipment.
- C. The Contractor shall provide dust control measures for all streets where Work has been completed or is ongoing and for all streets utilized as detour routes during construction.
 - 1. Dust shall be controlled by adding either granular or liquid chloride palliative or other approved materials in a sufficient amount to control the dust.
 - 2. Where extreme dry conditions exist, the Village Engineer or qualified Village Agent may also require water to be added to the street surface.
 - 3. If the Contractor fails to control the dust from construction activities or clean adjacent streets within a reasonable period of time after a request from the Owner/Village Engineer or qualified Village Agent the Owner will hire it done and deduct the cost from the escrow account and shall stop the Work until such time as all streets are properly maintained.

- D. Spillage of materials or mud tracking on streets or roads where hauling or trucking takes place shall be prevented.
- E. Any accidental spillage or tracking shall be immediately cleaned up as required by the Village Engineer or qualified Village Agent.
- F. A construction procedure in which the streets are continuously cleaned up on a block-by-block basis is an important part of this project. The Contractor shall clean up each block of constructed improvements and shall secure permission from the Village Engineer or qualified Village Agent before beginning construction on each new block of the project.
- G. Where it becomes necessary to remove any existing surfacing or pavement, trenches across traffic lanes not closed to traffic shall be provided with temporary trench cover.
 - 1. Minimum requirements for temporary trench cover shall be 8 inches of 21AA crushed aggregate compacted to not less than 95% of the maximum dry density as determined by ASTM D1557 or as specified by the Village Engineer or qualified Village Agent.
 - 2. Temporary trench cover shall be properly maintained by the Contractor until permanent trench cover is placed.

3.03 CLEARING

- A. See Section 31 10 00 for clearing requirements.

3.04 REMOVING TREES, STUMPS, AND CORDUROY

- A. See Section 31 10 00 for tree, stump, and corduroy removal requirements.

3.05 REMOVING DRAINAGE STRUCTURES, CULVERTS, WATER MAIN, AND SEWERS

- A. See Section 31 23 16.13 for drainage structure and pipe removal requirements.

3.06 REMOVING MISCELLANEOUS STRUCTURES AND MATERIALS

- A. See Section 31 23 16.13 for miscellaneous structure and material removal requirements.

3.07 ROADWAY EARTHWORK

- A. The Contractor shall complete roadway earthwork in accordance with MDOT Standard Specifications for Construction - Section 205 with the following modification(s):
 - 1. Salvaged topsoil shall be stockpiled in a location approved by the Village Engineer or qualified Village Agent.
 - 2. All topsoil, salvaged or imported, shall be run through a 1 inch screen prior to placement.
- B. Finished Product:
 - 1. The Contractor shall be responsible for providing a completely stabilized subgrade, compacted and graded in accordance with the plan cross-sections.
 - 2. The subgrade shall be approved by the Village Engineer or qualified Village Agent on MDOT Form 1125, www.mdotjboss.state.mi.us/webforms/GetDocument.htm?fileName=1125.pdf, prior to placement of subbase materials.
 - 3. Approval of the subgrade by the Village Engineer or qualified Village Agent shall not relieve the Contractor of the responsibility for providing and maintaining a completely stabilized and compacted subgrade.

3.08 SUBBASE

- A. Where indicated on the Drawings, the Contractor shall install a subbase.
- B. Contractor shall install the subbase in accordance with MDOT Standard Specifications for Construction - Section 301 with the following modification(s):
 - 1. All requirements found in MDOT Standard Specifications for Construction - Section 302 shall apply to subbase except the following:
 - a. Tolerances.
 - b. Additives.
- C. Finished Product:
 - 1. The Contractor shall be responsible for providing a completely stabilized subbase, compacted and graded in accordance with the plan cross-sections.
 - 2. The subbase shall be approved by the Village Engineer or qualified Village Agent on MDOT Form 1125, www.mdotjboss.state.mi.us/webforms/GetDocument.htm?fileName=1125.pdf, prior to placement of aggregate base course materials.
 - 3. Approval of the subbase by the Village Engineer or qualified Village Agent shall not relieve the Contractor of the responsibility for providing and maintaining a completely stabilized and compacted subbase.

3.09 AGGREGATE BASE COURSE

- A. The Contractor shall install the aggregate base course in accordance with MDOT Standard Specifications for Construction - Section 302.
- B. Finished Product:
 - 1. The Contractor shall be responsible for providing a completely stabilized aggregate base course, compacted and graded in accordance with the plan cross-sections.
 - 2. The aggregate base course shall be approved by the Village Engineer or qualified Village Agent on MDOT Form 1125, www.mdotjboss.state.mi.us/webforms/GetDocument.htm?fileName=1125.pdf, prior to placement of HMA materials. Perform proofroll when directed by the Village Engineer or qualified Village Agent.
 - 3. Approval of the aggregate base course by the Village Engineer or qualified Village Agent shall not relieve the Contractor of the responsibility for providing and a maintaining a completely stabilized and compacted aggregate base course.

3.10 HMA BASE CRUSHING AND SHAPING

- A. Where indicated on the Drawings, the Contractor shall crush and shape the existing HMA. Perform proofroll when directed by the Village Engineer or qualified Village Agent.
- B. The Contractor shall complete this Work in accordance with MDOT Standard Specifications for Construction - Section 305.

3.11 GEOTEXTILES FOR BASE

- A. Where indicated on the Drawings, or as directed by Village Engineer or qualified Village Agent, the Contractor shall install geotextile products for stabilization or separation.
- B. The Contractor shall install geotextiles for base in accordance with MDOT Standard Specifications for Construction - Section 308.

3.12 CURB AND GUTTER

- A. Contractor shall install curb and gutter in accordance with MDOT Standard Specifications for Construction - Section 802 with the following modification(s):
 - 1. Stenciling of survey station numbers is not required.
- B. Reinforcing bars shall not extend through expansion joints.
- C. Forming:
 - 1. In slip forming, the Contractor shall use such methods and procedures to ensure an extruded curb and gutter which is true to line, grade and cross-section, free from sags or slumps.
 - 2. Forms used for conventionally formed curb and gutter shall be straight, true and clean and subject to the approval of the Village Engineer or qualified Village Agent.
 - 3. The Contractor will be required to remove and replace curb and gutter with defects and poor workmanship and/or poor appearance at the Contractor's expense.
- D. Adjusting Catch Basins:
 - 1. Catchbasin castings shall be properly adjusted prior to placement of concrete curb and gutter in accordance with Section 33 05 13.

3.13 CONCRETE SIDEWALK, SIDEWALK RAMPS, AND STEPS

- A. Contractor shall install sidewalk, sidewalk ramps, and steps in accordance with MDOT Standard Specifications for Construction - Section 803, ATBCB PROWAG, and ADA Standards.
- B. Saw cuts:
 - 1. Saw cuts on concrete, bituminous, or a combination thereof shall be made at the nearest existing control joint or as directed by the Village Engineer or qualified Village Agent.
 - 2. In removing old pavement, curb, gutter, sidewalk, driveways, or similar structures where adjoining surfaces of the existing structures are to be left in the finish Work, the old structure shall be removed to existing joints or sawed to a true line with a power driven concrete saw to full depth.
 - 3. The Contractor shall take any precautions necessary to maintain a clean vertical edge on the saw cut throughout the duration of Work.
 - 4. Prior to concrete placement, any spalled or otherwise damaged edge shall be re-cut as required by the Village Engineer or qualified Village Agent.
- C. Sidewalk, sidewalk ramps, and steps shall be constructed to lines and grades as set by the Village Engineer or qualified Village Agent or in accordance with the Village Engineer or qualified Village Agent's instructions.
- D. Any cut or fill shall be no less than 1 foot wider on each side than the width of the walk to be built upon it and sloped to meet existing grade as directed by the Village Engineer or qualified Village Agent.
- E. Base Preparation:
 - 1. The base under the concrete shall be compacted to 95% maximum dry density as determined by ASTM D1557.
 - 2. Compaction shall be acquired with the use of a mechanical tamper, or other similar and effective equipment.
- F. Contractor shall furnish and provide personnel and barricade devices to protect concrete from vandalism or damage.

- G. Contractor shall replace any newly placed concrete with visible cracks or concrete showing injury or damage at no cost to the Owner.
- H. Any property irons that may be removed during construction shall be referenced under the supervision of the Village Engineer or qualified Village Agent and replaced after construction by a Land Surveyor registered in the State of Michigan at no expense to the Owner.

3.14 PLANT PRODUCED HOT MIX ASPHALT

- A. The Contractor shall install HMA in accordance with MDOT Standard Specifications for Construction - Section 501 with the following modification(s):
 - 1. The Contractor shall be responsible for providing a completely stabilized, fully compacted HMA base, leveling, and wearing course of the required cross-section, without defects. MDOT Standard Specifications for Construction - Section 501.03.N.1 is not applicable.
- B. HMA Placement Schedule:
 - 1. Contractor's progress schedule shall reflect a wait period of a minimum of 30 days between placement of HMA leveling and wearing course.
 - 2. On all roadways, and on parking lots and driveways, when conditions of the Final Site Plan Approval state that the wearing course is not to be constructed until the following construction season, the Contractor shall provide a job mix formula with sufficient bitumen content to eliminate loss of aggregate "raveling" during the interim winter period and the leveling course shall provide a smooth neat interim cohesive road surface free for cracking and weak areas.
 - a. Delay final adjustment of street castings until immediately prior to wearing course installation.
- C. Adjusting Structures:
 - 1. All drainage structures, monument boxes, water shutoffs, and other utility castings lying within the roadbed shall be adjusted and cleaned of all dirt and debris after leveling and before wearing course.
 - 2. Drainage structures shall be properly adjusted in accordance with Section 33 05 13.
 - 3. The use of concrete to fill the void around the casting will not be allowed.
- D. HMA Placement:
 - 1. The vertical and horizontal faces of existing pavement and curb (asphalt and concrete) shall be coated with an asphalt emulsion applied to a clean, dry surface with a pressure distributor.
 - 2. Apply a uniform bond coat at a minimum rate of 0.10 gallons per square yard ahead of paving operations to allow the emulsion to cure before placing HMA.
 - 3. Do not leave pools of bond coat on the surface and do not spray the bond coat on adjacent pavement surfaces that will remain exposed after construction.
 - 4. Apply the bond coat to each HMA layer and to the vertical edge of the adjacent pavement and curb prior to placing subsequent layers.
 - 5. Bond coat application must be approved by Engineer before paving can begin. Any tracking onto permanent pavement markings shall be promptly removed. Pavement marking replacement may be required by the Village Engineer or qualified Village Agent.
 - 6. Where the base course and/or leveling course material does not meet the requirements of the plan cross-section for proper crown, slope, or grade elevation, or required tolerances, the Contractor shall be responsible to bring the cross-section to acceptable standards by the addition of new leveling and/or wearing course material.

3.15 CONCRETE DRIVEWAYS

- A. The Contractor shall install concrete driveways in accordance with MDOT Standard Specifications for Construction - Section 802.

3.16 FIELD QUALITY CONTROL

- A. The subgrade, subbase, aggregate base course, and HMA shall be tested in accordance with the MDOT Density Control Handbook.
- B. Contractor shall furnish the Village Engineer or qualified Village Agent with sufficient materials for required for acceptance testing.

END OF SECTION

SECTION 34 10 00

RESOLUTION 5 OF 2017 REGARDING DRIVEWAY REPLACEMENT

RESOLUTION

NO. : 17 - 05

VILLAGE OF PINCKNEY

DATE: March 27, 2017

**RESOLUTION TO ESTABLISH REQUIREMENTS FOR DRIVEWAY REPLACEMENT
DURING STREET RECONSTRUCTION PROJECTS WITH CURB AND GUTTER**

WHEREAS; in preparation of an upcoming road reconstruction project it was identified that the village does not have a written policy regarding approach size (new or replacement);

WHEREAS; the village has no written policy on financial responsibility of the replacement approaches;

NOW, THEREFORE, BE IT RESOLVED:

1. Drive approaches replaced as part of a street reconstruction project shall meet the following requirements:

- All residential driveways shall be installed on at least 4 inches of MDOT Class II granular material or engineer approved native material
- All residential driveway approach shall be non-reinforced concrete with minimum a thickness of 6 inches, MDOT P1, 6.0 sack, jointed in accordance with industry standards
- Maximum width of approach to be paid for by the Village at the sidewalk or 6 feet inside the right-of-way (one car garage): 12 feet
- Maximum width of approach to be paid for by the Village at the sidewalk or 6 feet inside the right-of-way (two car or greater garage): 16 feet
- Maximum entering taper width: 5.5 feet unless otherwise approved by the Village Engineer or Qualified Village Agent
- Maximum exiting taper width: 5.5 feet unless otherwise approved by the Village Engineer or Qualified Village Agent

2. The Village Engineer or Qualified Village Agent will stake the location of the proposed drive approach during construction based on existing site conditions (including existing driveway locations), sound engineering judgement, and the Village Municipal Standards for Construction. The property owner must work with the Village Engineer or Qualified Village Agent to request any modifications to the proposed location. The property owner must understand that construction projects move swiftly and there is no guarantee either express or implied that the construction work schedule

can accommodate a request to change the location of a drive opening if the Village is not given sufficient time to notify the contractor.

3. The property owner may request a wider driveway than specified above up to a maximum of 24 feet at the sidewalk. If no sidewalk exists then the maximum width will be measured at a point 6 feet inside the right-of-way to accommodate a future 5 foot wide sidewalk placed one foot inside the right-of-way. Any costs associated with the additional driveway width (including increasing the sidewalk thickness from 4 inches to 6 inches) shall be agreed on and paid for by the property owner prior to installation of the new curb and gutter. The property owner must understand that construction projects move swiftly and there is no guarantee either express or implied that the construction work schedule can accommodate a request for additional driveway width if the Village is not given sufficient time to notify the contractor.

4. Vacant lots shall be provided a curb opening only (no drive approach) upon request by the property owner. The width and location of opening shall be agreed on by the property owner and the Village Engineer or Qualified Village Agent. The property owner must understand that construction projects move swiftly and there is no guarantee either express or implied that the construction work schedule can accommodate a request for a drive opening if the Village is not given sufficient time to notify the contractor.

5. All non-residential driveways shall be reviewed on a case-by-case basis.

6. Property owners will be notified, by mail, of this policy prior to each reconstruction project and have thirty (30) days from the date of the letter to respond and make necessary payments.

Village Council Member Menosky offered the foregoing Resolution, and moved its adoption. The motion was seconded by Village Council Member Kauserud, and upon being put to a vote, the vote was as follows:

Linda E. Lavey, President	<u>Y</u>
Rebecca Foster, Trustee	<u>Y</u>
Eirik Kauserud, Trustee	<u>Y</u>
Teddy Kinczkowski, Trustee	<u>Y</u>
Heather R. Menosky, Trustee	<u>Y</u>
Thomas F. Pais, Trustee	<u>Y</u>
Robert Vedder, Trustee	<u>Y</u>

The President thereupon declared this Resolution approved and adopted by the Village Council of the Village of Pinckney this 27th day of March, 2017.

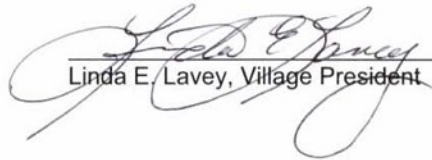
Linda E. Lavey, Village President

I hereby certify that the foregoing constitutes a true and complete copy of a resolution adopted by the Village Council of the Village of Pinckney, County of Livingston, Michigan, at a regular meeting held on March 27, 2017.

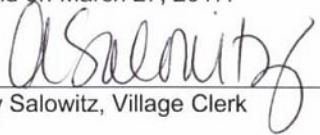
Amy Salowitz, Village Clerk

END OF SECTION

SECTION 48 80 00
UTILITY TRENCHES

PART 1 GENERAL

1.01 RELATED REQUIREMENTS

- A. Section 31 23 16.13 - Trenching: Trench requirements.
- B. Section 33 06 00 - Trace Wire and Locator Tape: Trace wire and locator tape requirements for pipe.

SEE NEXT PAGE(S) FOR DETAIL

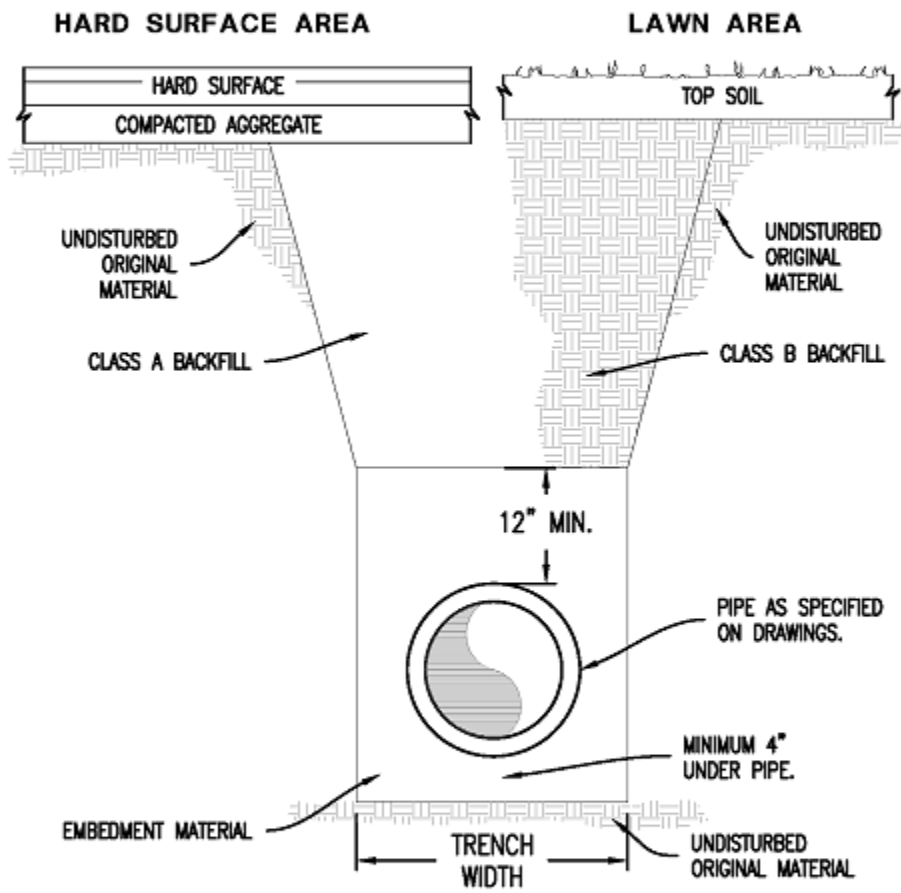

SECTION 48 80 01
CASTINGS AND GRATES

PART 1 GENERAL

1.01 RELATED REQUIREMENTS

- A. Section 33 05 13 - Manholes and Structures: Manhole requirements.
- B. Section 34 01 00 - Street and other Hard Surface Improvements: Casting adjustments.

SEE NEXT PAGE(S) FOR DETAIL

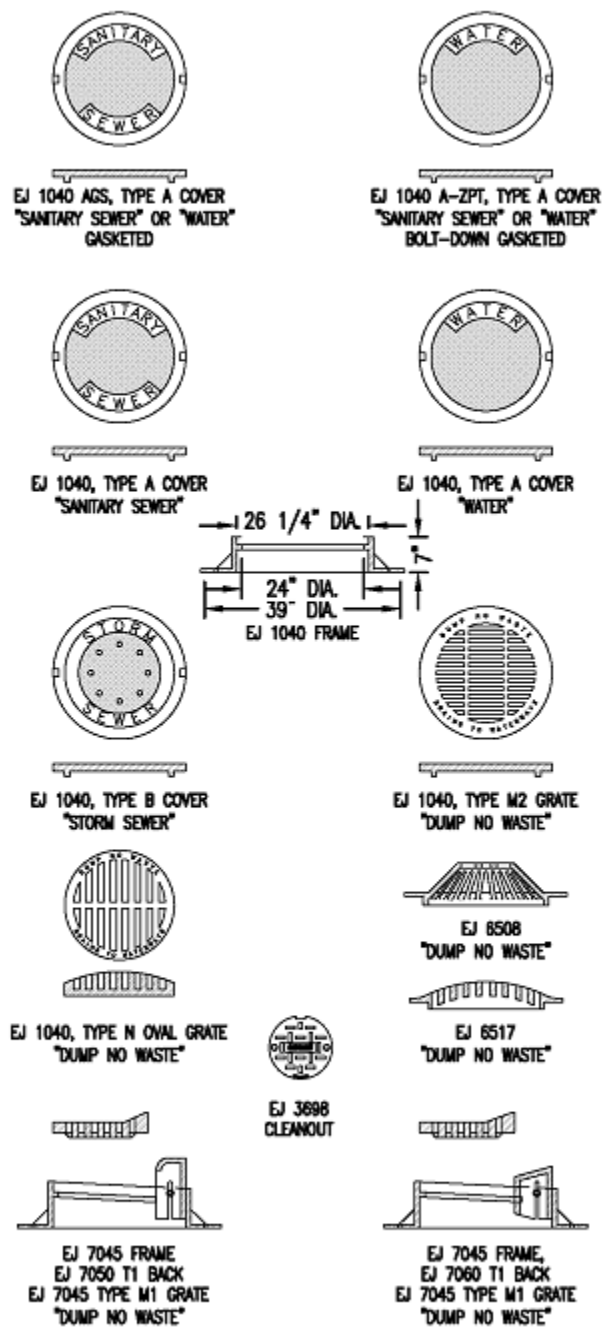

SECTION 48 80 03
WATER SOFTENER DRY WELL

PART 1 GENERAL

1.01 RELATED REQUIREMENTS

- A. Section 31 23 16.13 - Trenching: Embedment material.

NOTES:

- A. Dry well must be individually designed and sealed by a Professional Engineer licensed in the State of Michigan.
- B. Computations for the sizing of the dry well must be submitted to the Village of Pinckney for approval.
- C. Dry wells can be constructed by excavating an area in the ground and backfilling as shown on the detail. Precast concrete and plastic dry well tanks can also be utilized.
- D. All dry wells must be a minimum of 10 feet from the house or building and 50 feet from a private well.
- E. The bottom of the dry well must be 4 feet above the seasonally high groundwater level in soil suitable for drainage.
- F. Soil corings, borings or test pits must be performed to determine the adequacy of the soil to accept the design flow rates. Static water elevation should be identical.
- G. Generally, soils in the area of the dry well must be suitable for drainage.
- H. Dry well must be inspected by the Village Engineer or qualified Village Agent.
- Commercial dry wells must comply with notes A-H
 - Residential dry wells must comply with notes C-H
 - Plumbing shall meet LCBD Standards

SEE NEXT PAGE(S) FOR DETAIL

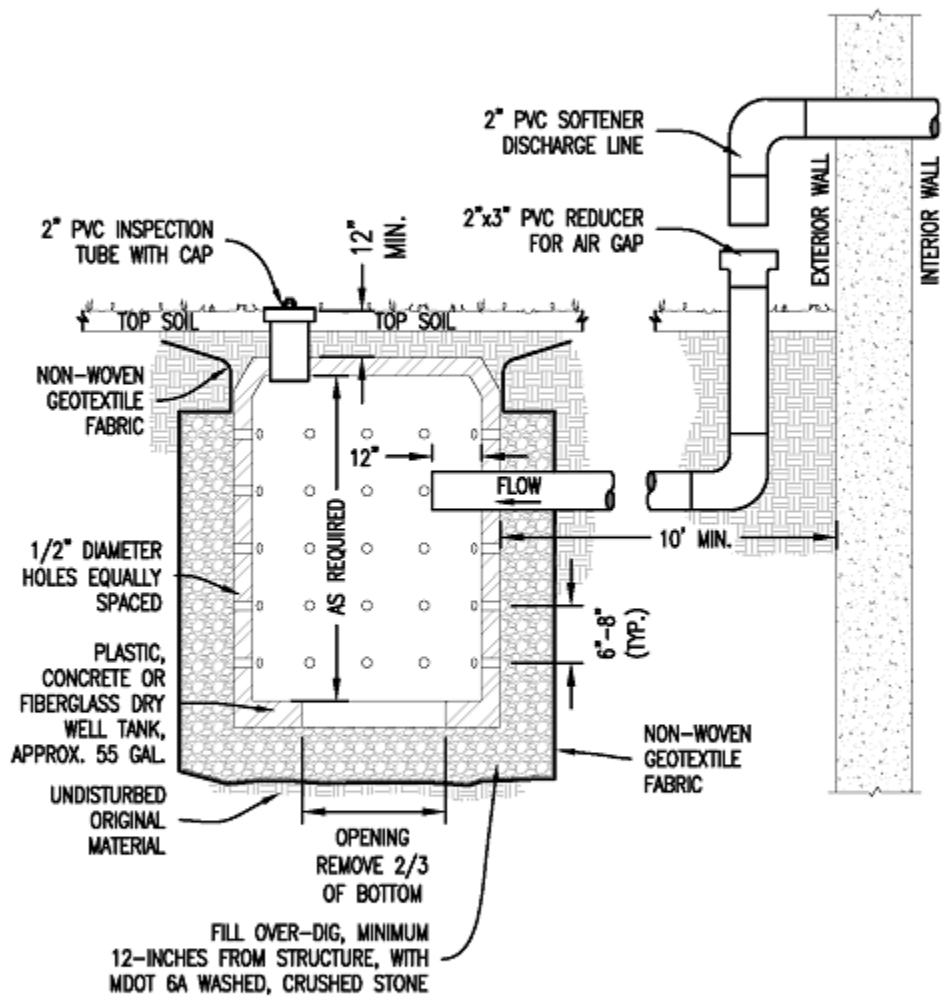

SECTION 48 80 10
WATERMAIN LOWERING

PART 1 GENERAL

1.01 RELATED REQUIREMENTS

- A. Section 31 23 16.13 - Trenching: Trench requirements.
- B. Section 33 06 00 - Trace Wire and Locator Tape: Trace wire and locator tape requirements for pipe.
- C. Section 33 09 01 - Installation and Acceptance Testing of Pipe and Accessories: Pipe installation requirements.

SEE NEXT PAGE(S) FOR DETAIL

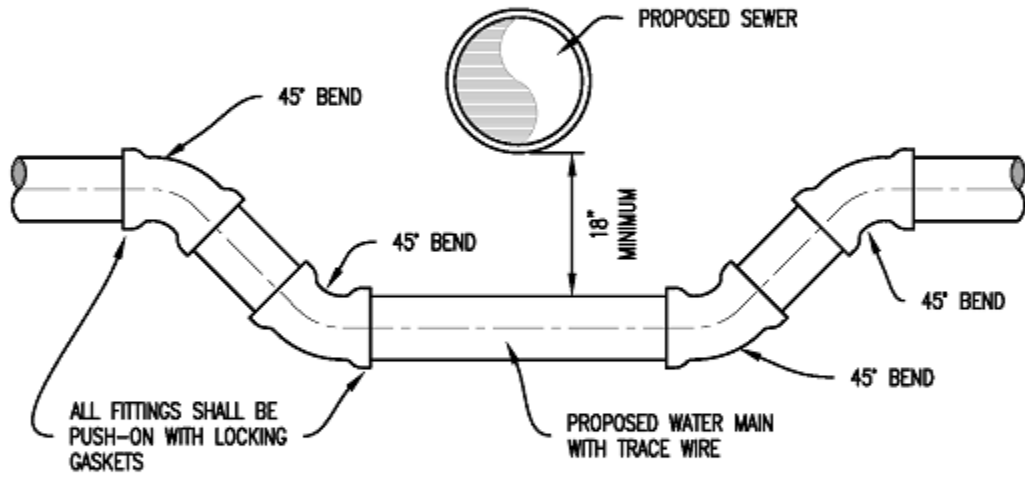

SECTION 48 80 11
WATERMAIN SEPARATION

PART 1 GENERAL

1.01 RELATED REQUIREMENTS

- A. Section 31 23 16.13 - Trenching: Trench requirements.
- B. Section 33 06 00 - Trace Wire and Locator Tape: Trace wire and locator tape requirements for pipe.
- C. Section 33 09 01 - Installation and Acceptance Testing of Pipe and Accessories: Pipe installation requirements.

SEE NEXT PAGE(S) FOR DETAIL

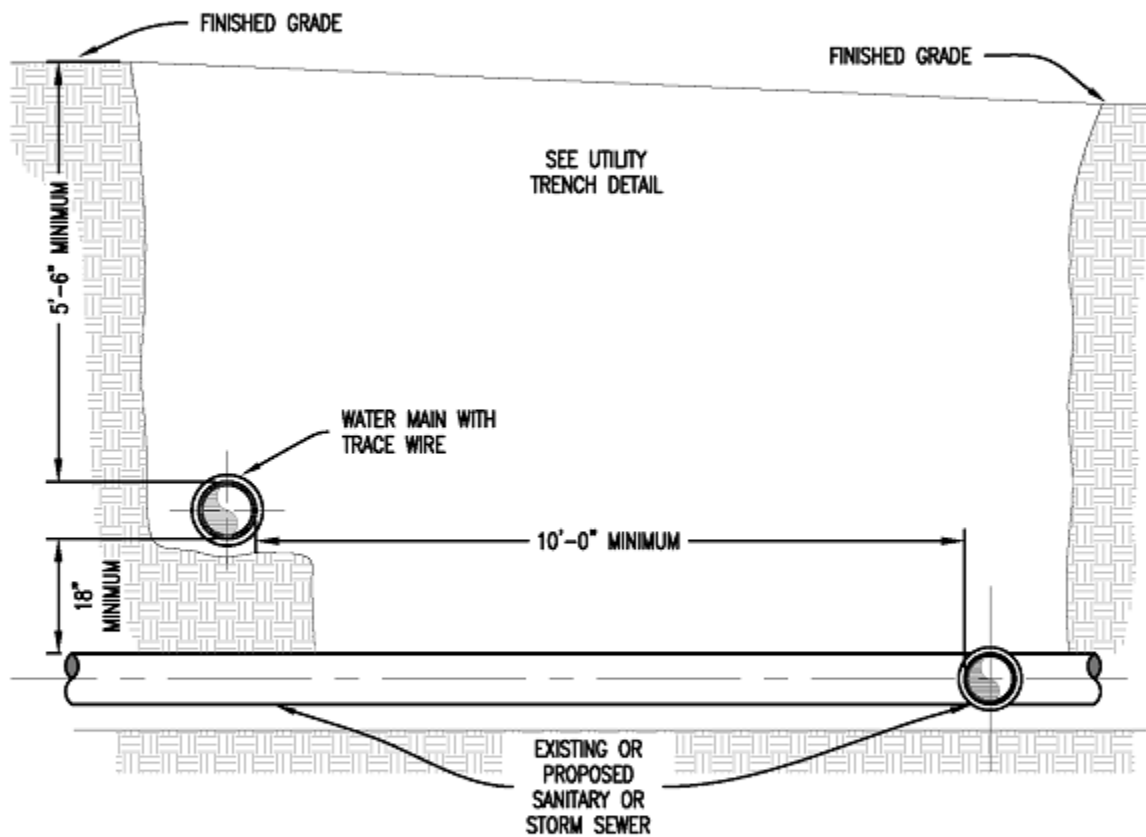

SECTION 48 80 12

GATE VALVES

PART 1 GENERAL

1.01 RELATED REQUIREMENTS

- A. Section 31 23 16.13 - Trenching: Trench requirements.
- B. Section 33 09 01 - Installation and Acceptance Testing of Pipe and Accessories: Gate valve installation requirements.
- C. Section 33 06 00 - Trace Wire and Locator Tape: Trace wire and locator tape near gate valves.
- D. Section 33 14 16 - Water Piping: Gate valve material requirements.

SEE NEXT PAGE(S) FOR DETAIL

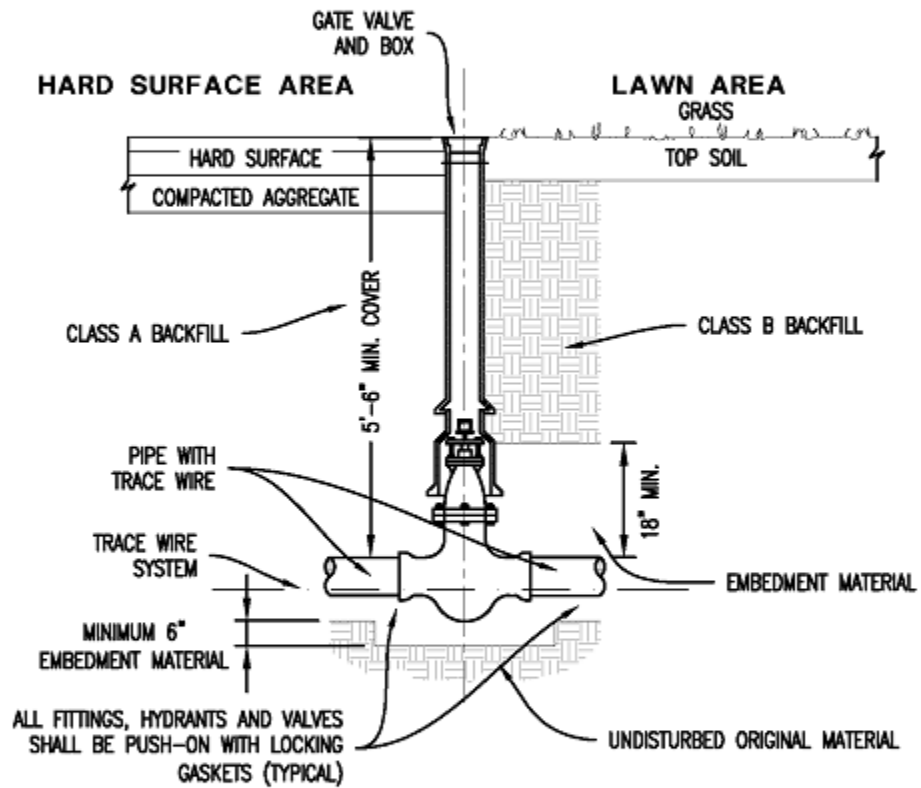

SECTION 48 80 13
GATE VALVE MANHOLES

PART 1 GENERAL

1.01 RELATED REQUIREMENTS

- A. Section 31 23 16.13 - Trenching: Embedment material.
- B. Section 33 05 13 - Manholes and Structures: Manhole requirements.
- C. Section 33 06 00 - Trace Wire and Locator Tape: Trace wire and locator tape location around manholes.
- D. Section 34 01 00 - Street and other Hard Surface Improvements: Casting adjustments.

SEE NEXT PAGE(S) FOR DETAIL

VALVE SIZE	MANHOLE DIAMETER
UP TO 8 INCHES	N/A, DIRECT BURY
12 INCHES	6 FOOT
16 INCHES	7 FOOT

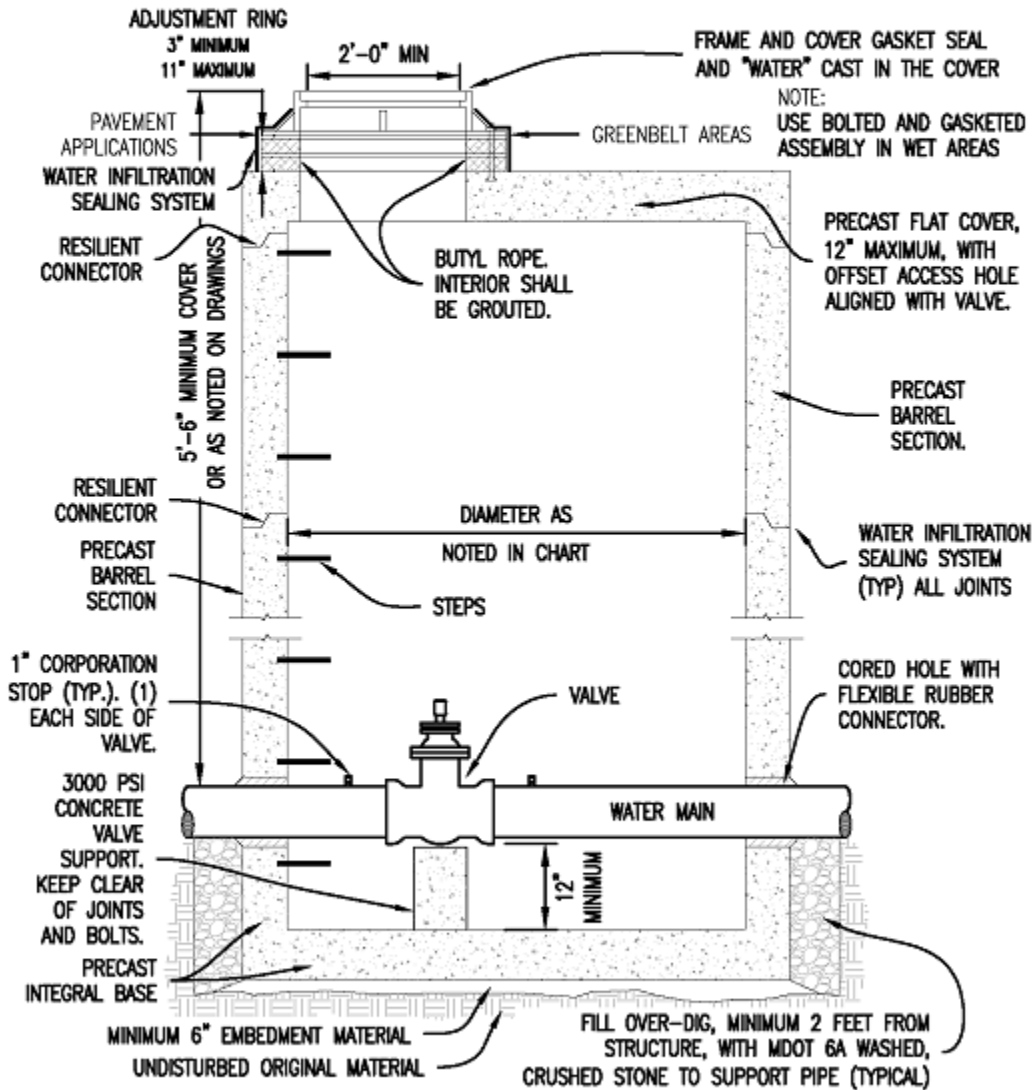

SECTION 48 80 14
WATERMAIN LIVETAP MANHOLES

PART 1 GENERAL

1.01 RELATED REQUIREMENTS

- A. Section 31 23 16.13 - Trenching: Embedment material.
- B. Section 33 05 13 - Manholes and Structures: Manhole requirements.
- C. Section 33 06 00 - Trace Wire and Locator Tape: Trace wire and locator tape location around manholes.
- D. Section 34 01 00 - Street and other Hard Surface Improvements: Casting adjustments.

SEE NEXT PAGE(S) FOR DETAIL

VALVE SIZE	MANHOLE DIAMETER
UP TO 8 INCHES	7 FOOT
12 INCHES & LARGER	8 FOOT

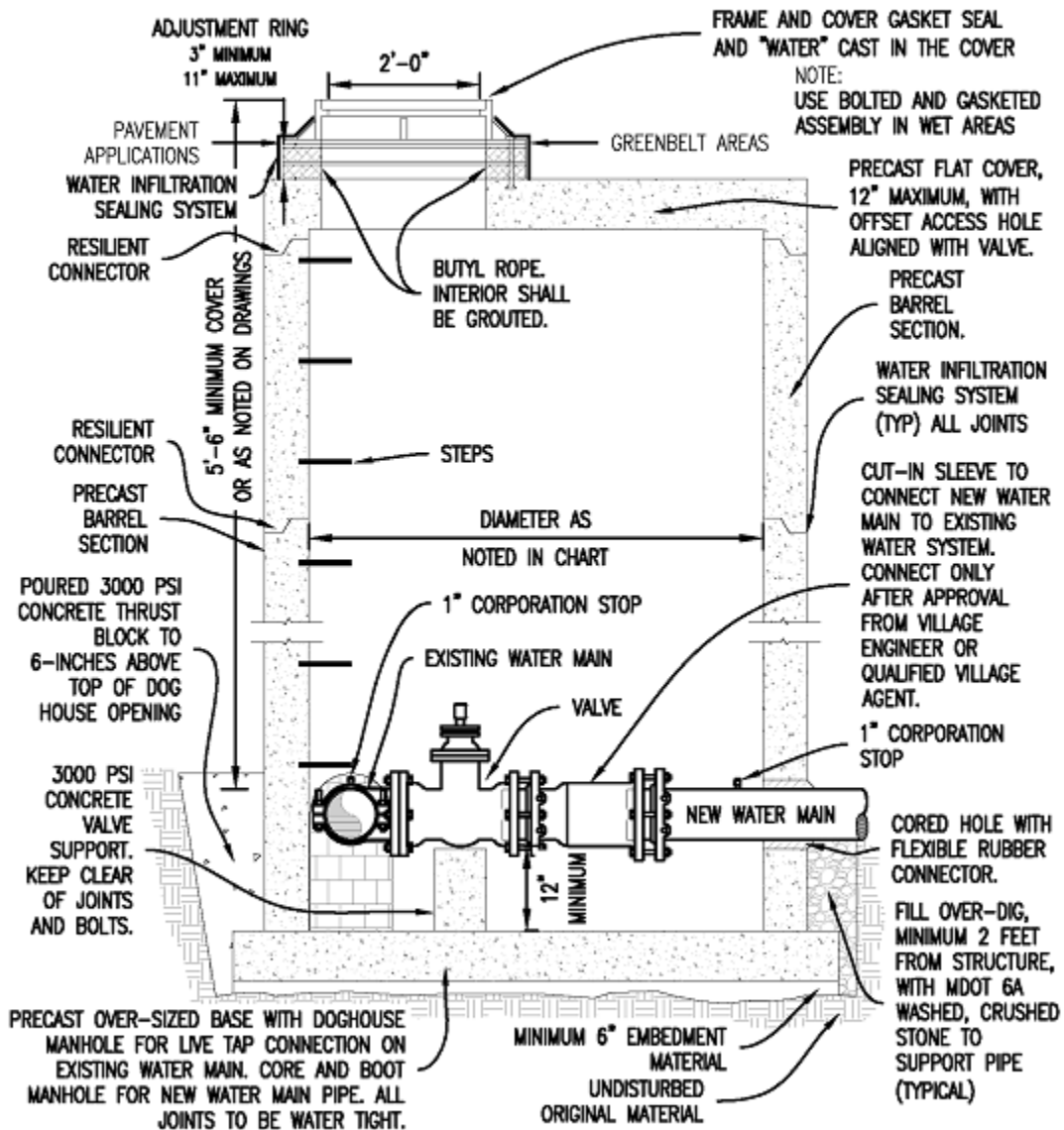

SECTION 48 80 15
RESIDENTIAL WATER METERS

PART 1 GENERAL

1.01 RELATED REQUIREMENTS

- A. Section 33 14 16 - Water Piping: Water meter requirements.

SEE NEXT PAGE(S) FOR DETAIL

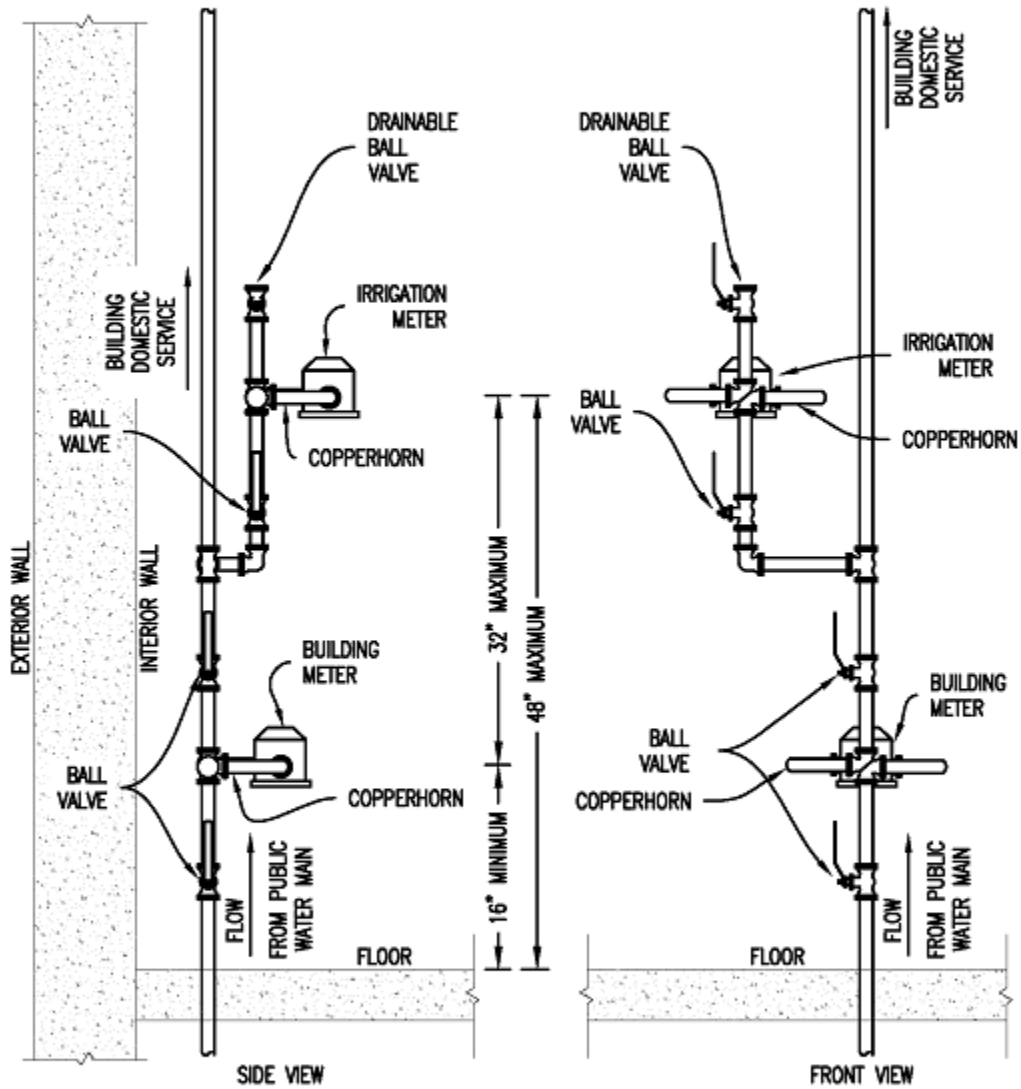

SECTION 48 80 16
WATER SERVICES

PART 1 GENERAL

1.01 RELATED REQUIREMENTS

- A. Section 31 23 16.13 - Trenching: Trench requirements.
- B. Section 33 06 00 - Trace Wire and Locator Tape: Service lead trace wire and locator tape requirements.
- C. Section 33 09 01 - Installation and Acceptance Testing of Pipe and Accessories: Service lead installation requirements.
- D. Section 33 14 16 - Water Piping: Service lead material requirements.

SEE NEXT PAGE(S) FOR DETAIL

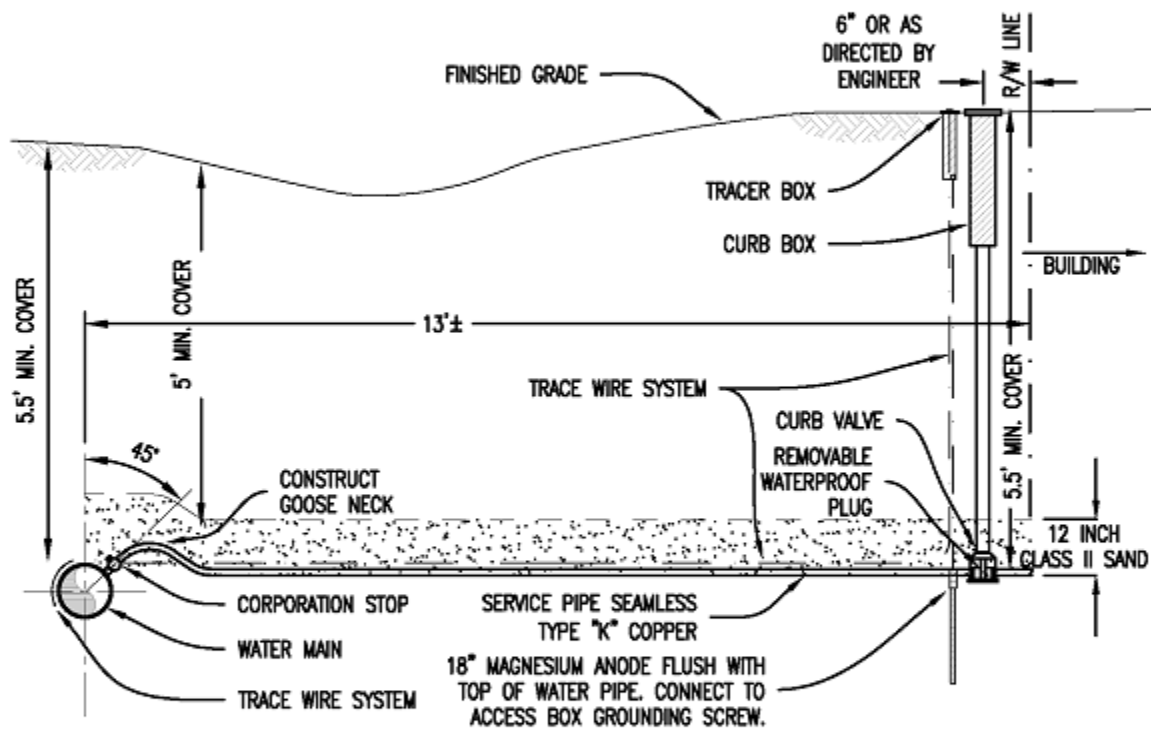

SECTION 48 80 17

HYDRANTS

PART 1 GENERAL

1.01 RELATED REQUIREMENTS

- A. Section 31 23 16.13 - Trenching: Trench requirements.
- B. Section 33 06 00 - Trace Wire and Locator Tape: Trace wire and locator tape location near hydrants.
- C. Section 33 09 01 - Installation and Acceptance Testing of Pipe and Accessories: Hydrant installation requirements.
- D. Section 33 13 00 - Disinfecting of Water Utility Distribution: Water system disinfection.
- E. Section 33 14 16 - Water Piping: Hydrant materials and configuration.

SEE NEXT PAGE(S) FOR DETAIL

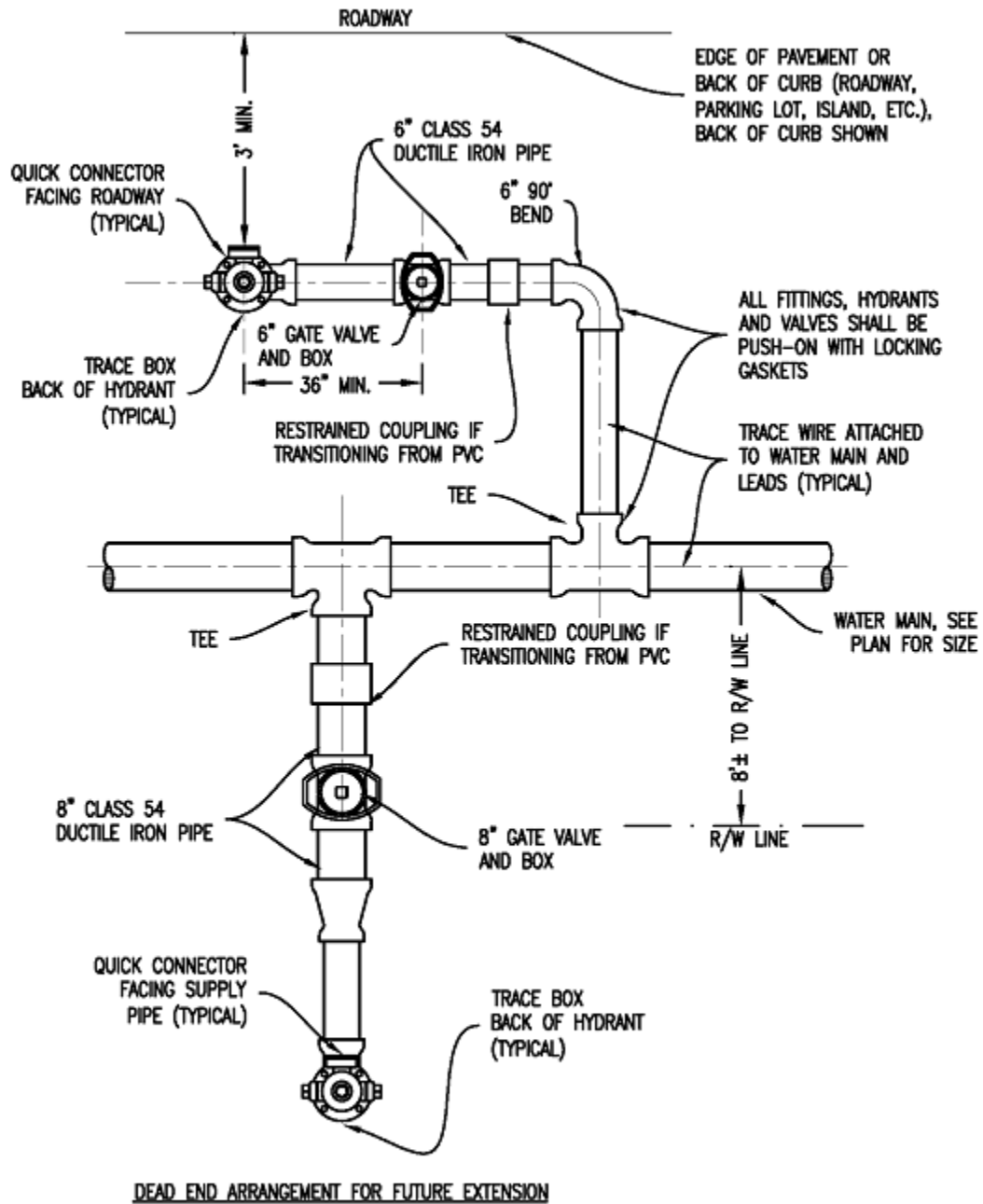

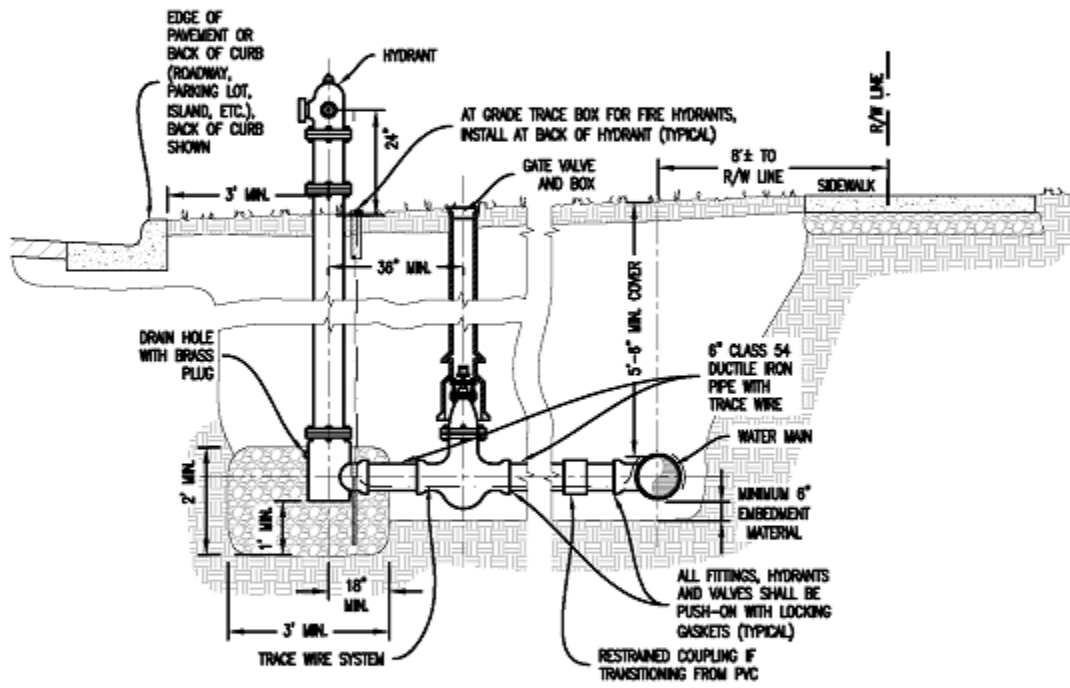

SECTION 48 80 18
WATER SYSTEM TRACE WIRE PLAN

PART 1 GENERAL

1.01 RELATED REQUIREMENTS

- A. Section 33 06 00 - Trace Wire and Locator Tape: Trace wire and locator tape location around manholes.

SEE NEXT PAGE(S) FOR DETAIL

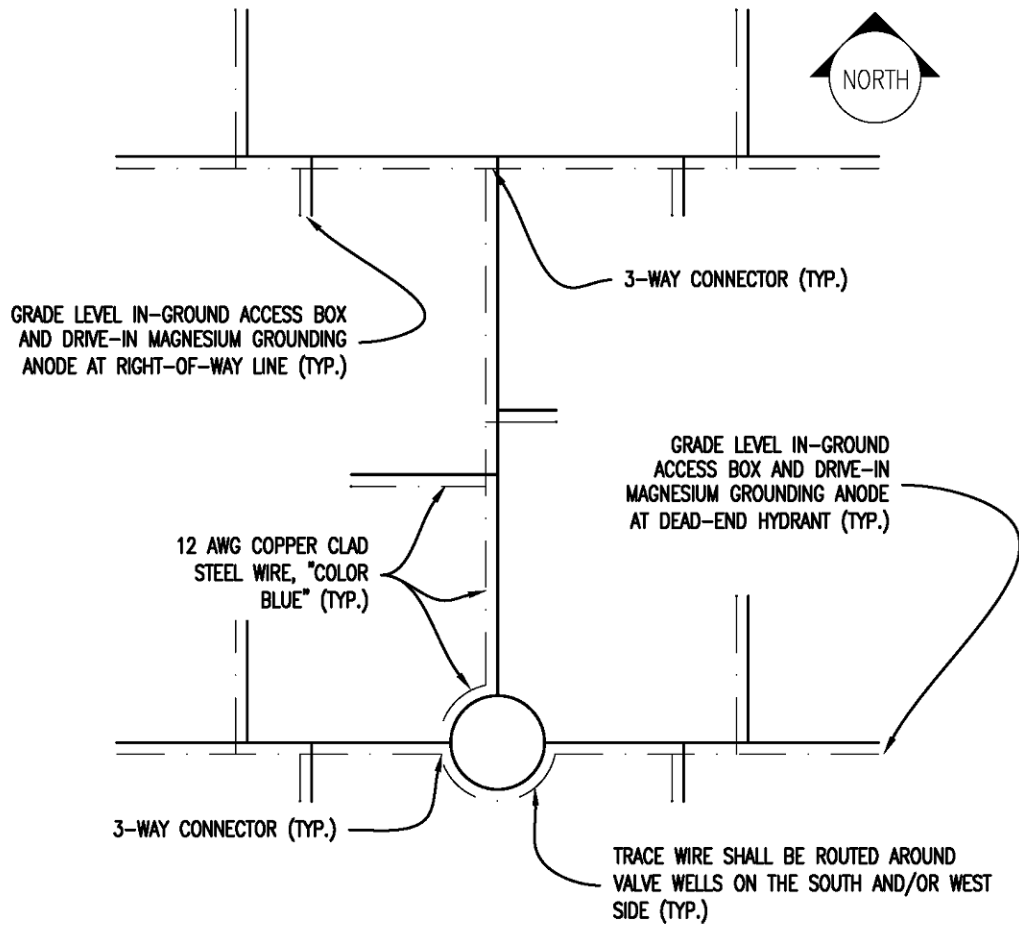

SECTION 48 80 20
STANDARD SANITARY MANHOLES

PART 1 GENERAL

1.01 RELATED REQUIREMENTS

- A. Section 31 23 16.13 - Trenching: Embedment material.
- B. Section 33 05 13 - Manholes and Structures: Manhole requirements.
- C. Section 33 06 00 - Trace Wire and Locator Tape: Trace wire and locator tape location around manholes.
- D. Section 33 09 01 - Installation and Acceptance Testing of Pipe and Accessories: Groundwater level measurement.
- E. Section 34 01 00 - Street and other Hard Surface Improvements: Casting adjustments.

SEE NEXT PAGE(S) FOR DETAIL

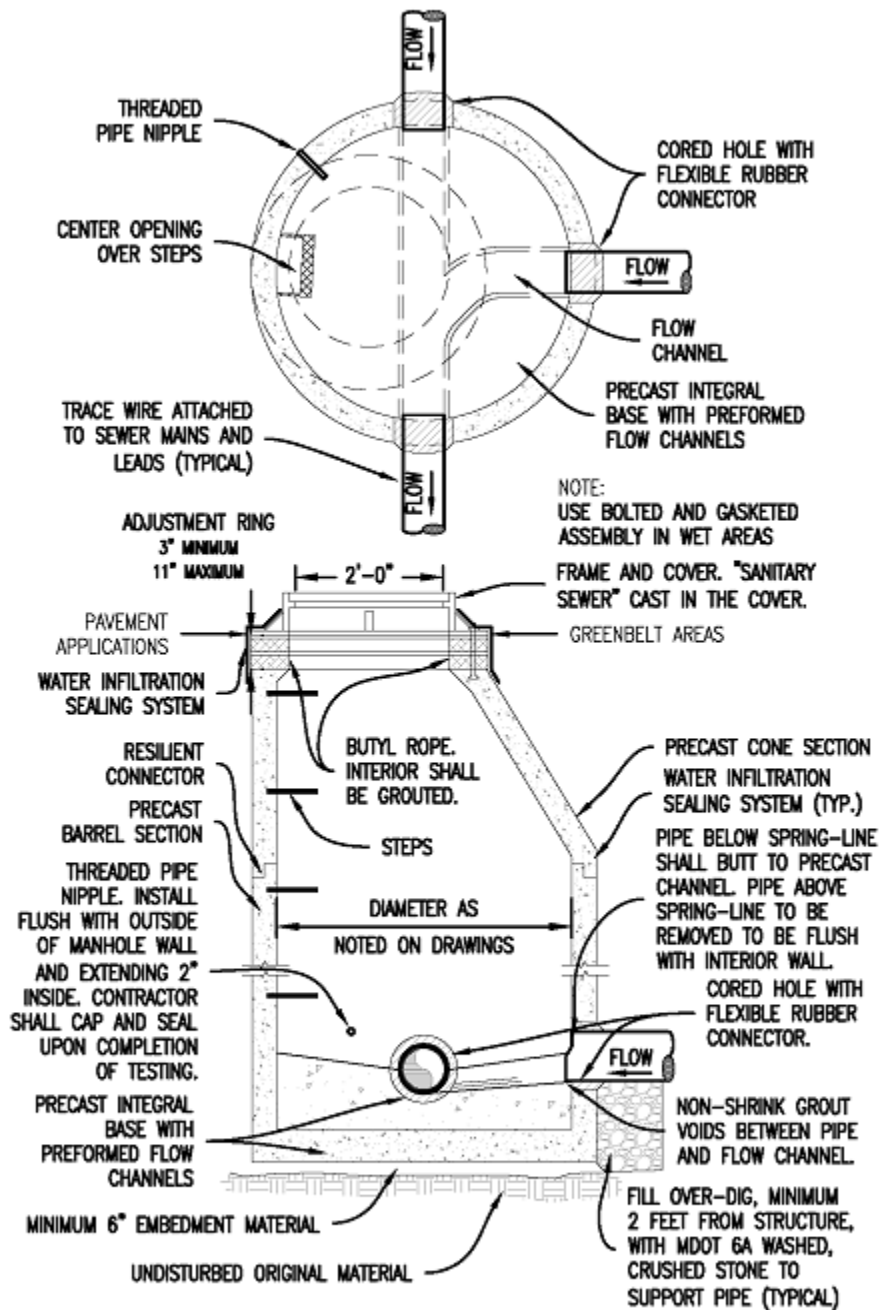

SECTION 48 80 21
SHALLOW SANITARY MANHOLES

PART 1 GENERAL

1.01 RELATED REQUIREMENTS

- A. Section 31 23 16.13 - Trenching: embedment material.
- B. Section 33 05 13 - Manholes and Structures: Manhole requirements.
- C. Section 33 06 00 - Trace Wire and Locator Tape: Trace wire and locator tape location around manholes.
- D. Section 33 09 01 - Installation and Acceptance Testing of Pipe and Accessories: Groundwater level measurement.
- E. Section 34 01 00 - Street and other Hard Surface Improvements: Casting adjustments.

SEE NEXT PAGE(S) FOR DETAIL

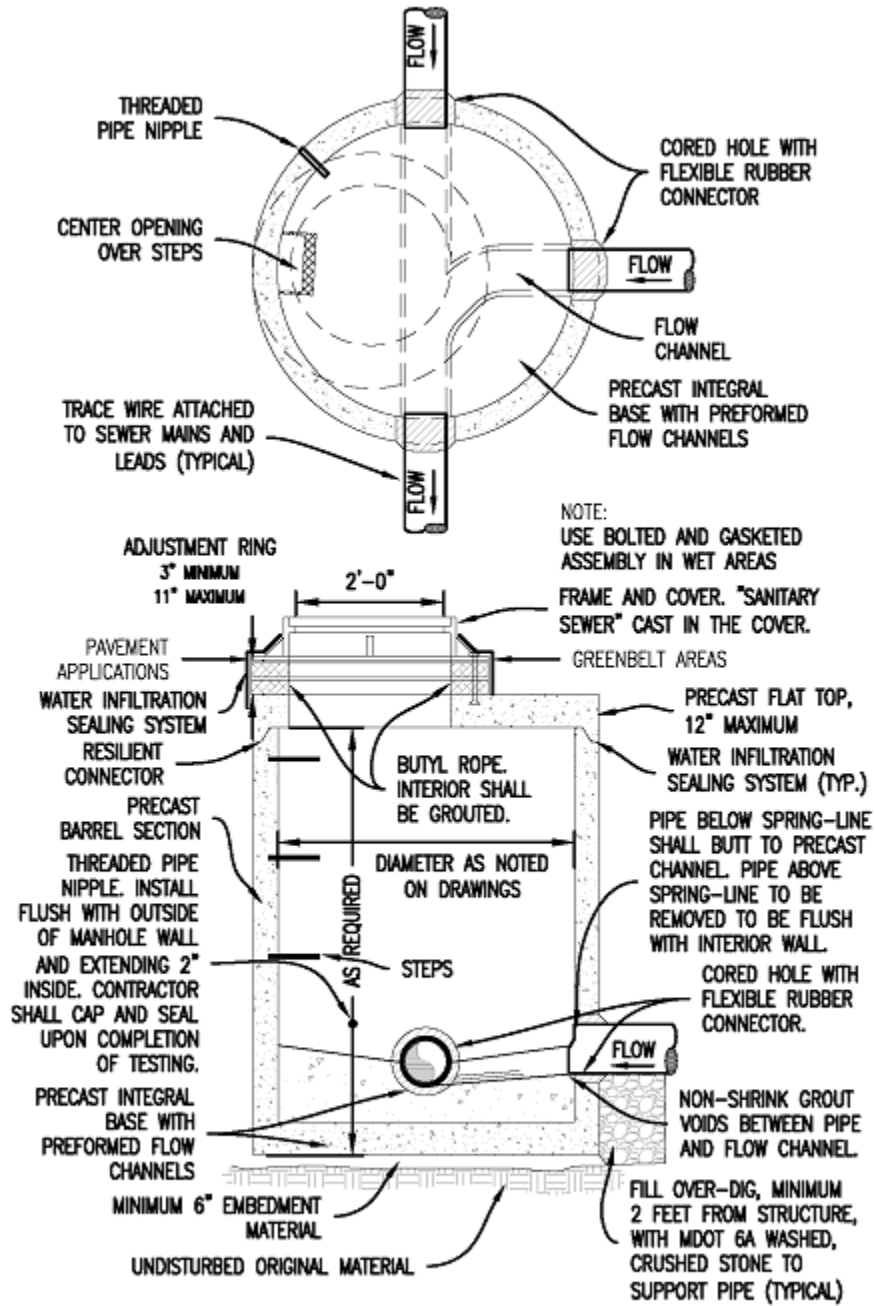

SECTION 48 80 22
SANITARY RISERS

PART 1 GENERAL

1.01 RELATED REQUIREMENTS

- A. Section 31 23 16.13 - Trenching: Trench requirements.
- B. Section 33 06 00 - Trace Wire and Locator Tape: Service lead trace wire and locator tape requirements.
- C. Section 33 09 01 - Installation and Acceptance Testing of Pipe and Accessories: Service lead installation requirements.

SEE NEXT PAGE(S) FOR DETAIL

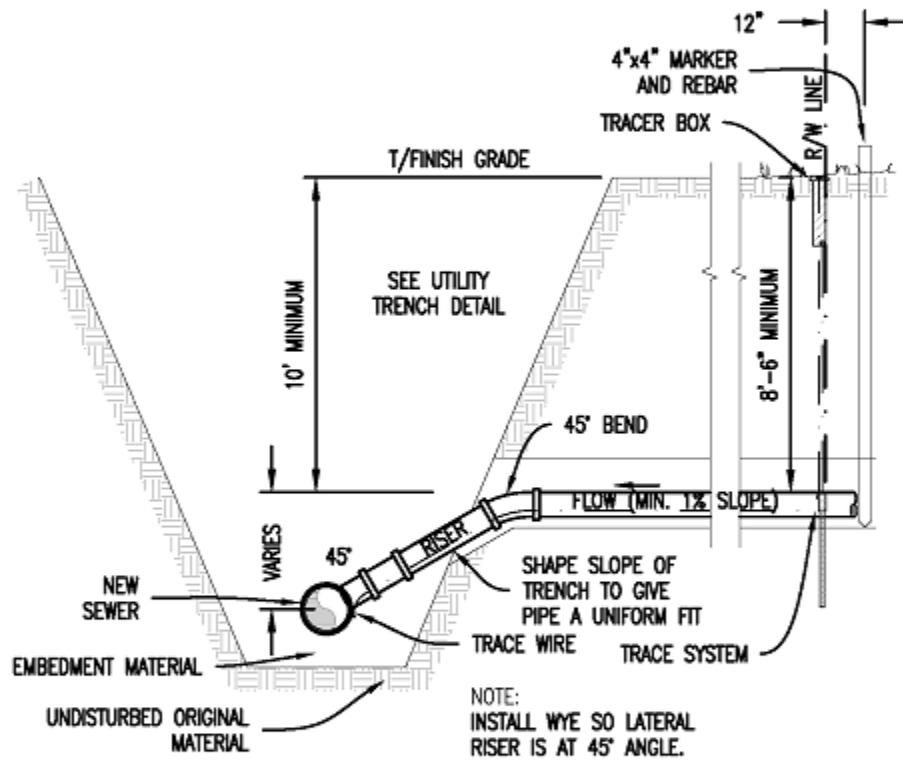

SECTION 48 80 23
DEEP CUT SANITARY RISERS

PART 1 GENERAL

1.01 RELATED REQUIREMENTS

- A. Section 31 23 16.13 - Trenching: Trench requirements.
- B. Section 33 06 00 - Trace Wire and Locator Tape: Service lead trace wire and locator tape requirements.
- C. Section 33 09 01 - Installation and Acceptance Testing of Pipe and Accessories: Service lead installation requirements.

SEE NEXT PAGE(S) FOR DETAIL

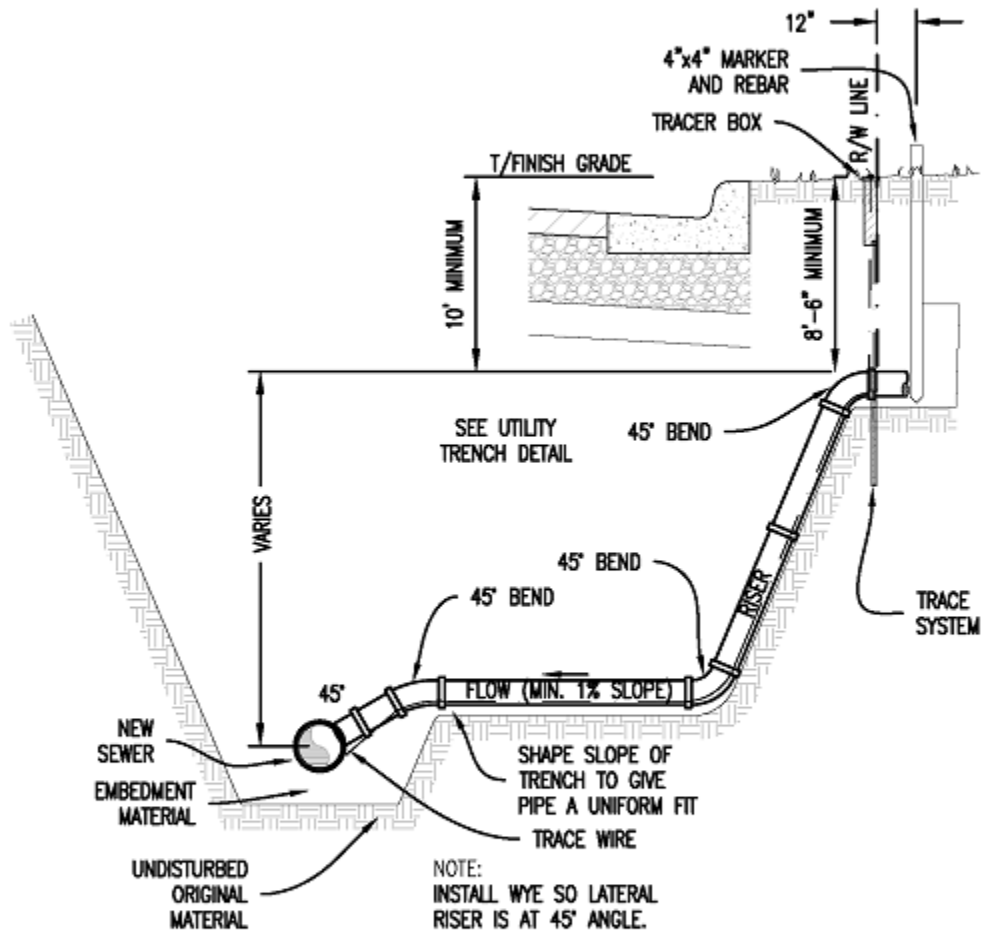

SECTION 48 80 24
SANITARY DROP MANHOLE

PART 1 GENERAL

1.01 RELATED REQUIREMENTS

- A. Section 31 23 16.13 - Trenching: Embedment material.
- B. Section 33 05 13 - Manholes and Structures: Manhole requirements.
- C. Section 33 06 00 - Trace Wire and Locator Tape: Trace wire and locator tape location around manholes.
- D. Section 33 09 01 - Installation and Acceptance Testing of Pipe and Accessories: Groundwater level measurement.
- E. Section 34 01 00 - Street and other Hard Surface Improvements: Casting adjustments.

SEE NEXT PAGE(S) FOR DETAIL

PVC CAP DETAIL
(REMOVE TOP HALF OF CAP FACE)



SEWER SIZE	DROP SIZE	MANHOLE SIZE
UP TO 10 INCH	8 INCH	4 FOOT
12 TO 18 INCH	10 INCH	4 FOOT
UP TO 30 INCH	18 INCH	5 FOOT

NOTE:
USE BOLTED AND GASKETED
ASSEMBLY IN WET AREAS

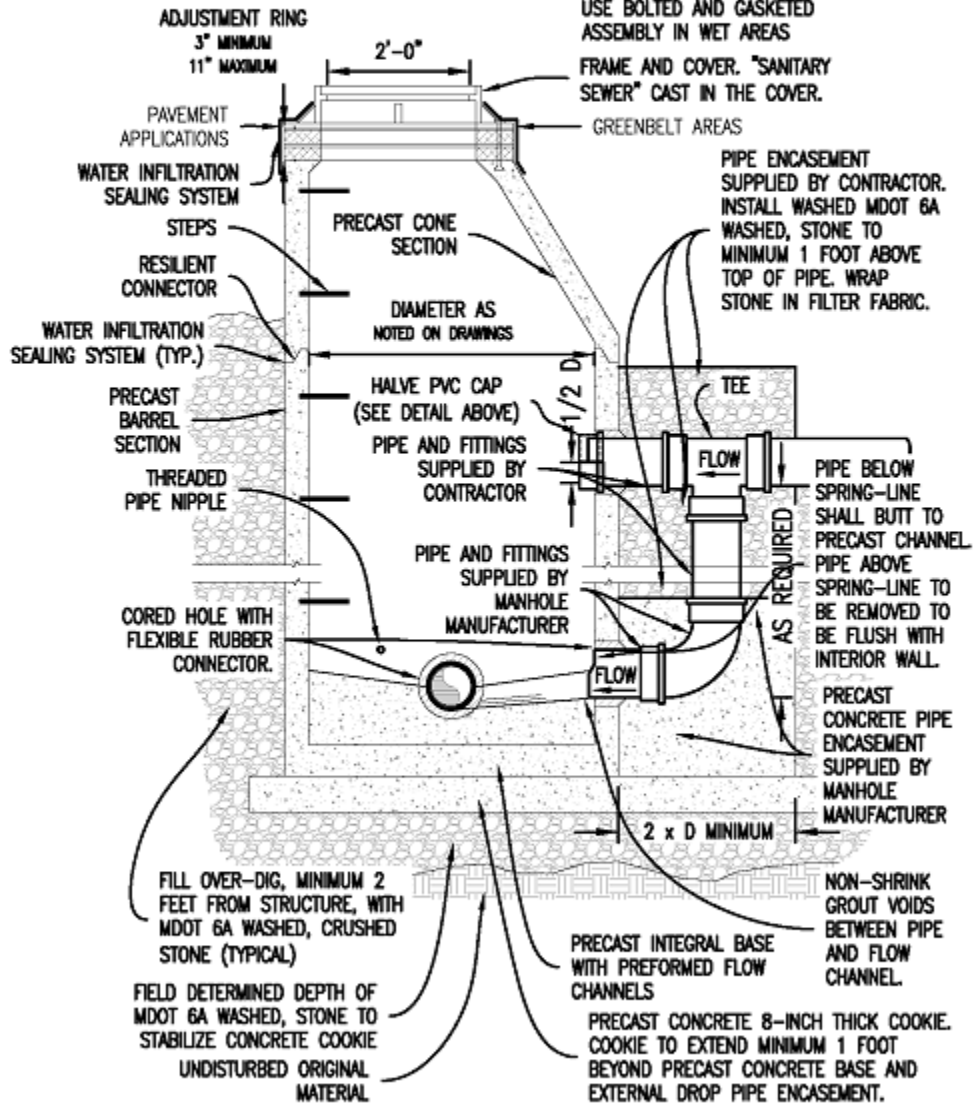

SECTION 48 80 25
SANITARY SEWER CLEANOUT

PART 1 GENERAL

1.01 RELATED REQUIREMENTS

- A. Section 33 06 00 - Trace Wire and Locator Tape: Trace wire and locator tape location around manholes.

SEE NEXT PAGE(S) FOR DETAIL

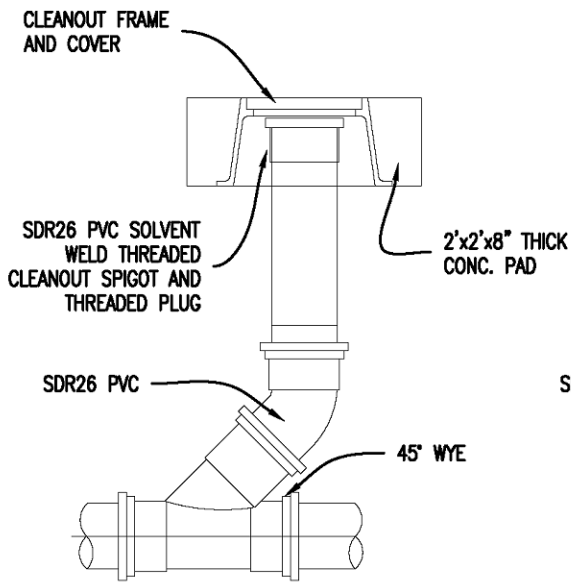

INTERMEDIATE SANITARY CLEANOUT DETAIL

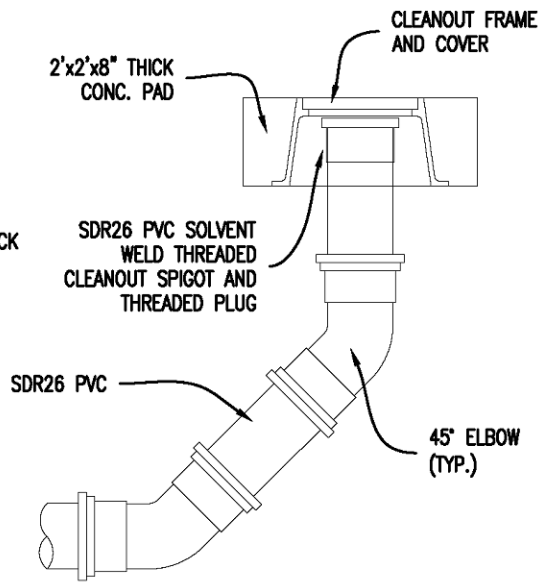

TERMINAL SANITARY CLEANOUT DETAIL

SECTION 48 80 26

SANITARY SEWER SYSTEM TRACE WIRE PLAN

PART 1 GENERAL

1.01 RELATED REQUIREMENTS

- A. Section 33 06 00 - Trace Wire and Locator Tape: Trace wire and locator tape location around manholes.

SEE NEXT PAGE(S) FOR DETAIL

SECTION 48 80 30
STORM MANHOLES

PART 1 GENERAL

1.01 RELATED REQUIREMENTS

- A. Section 31 23 16.13 - Trenching: Embedment material.
- B. Section 33 05 13 - Manholes and Structures: Manhole requirements.
- C. Section 34 01 00 - Street and other Hard Surface Improvements: Casting adjustments.

SEE NEXT PAGE(S) FOR DETAIL

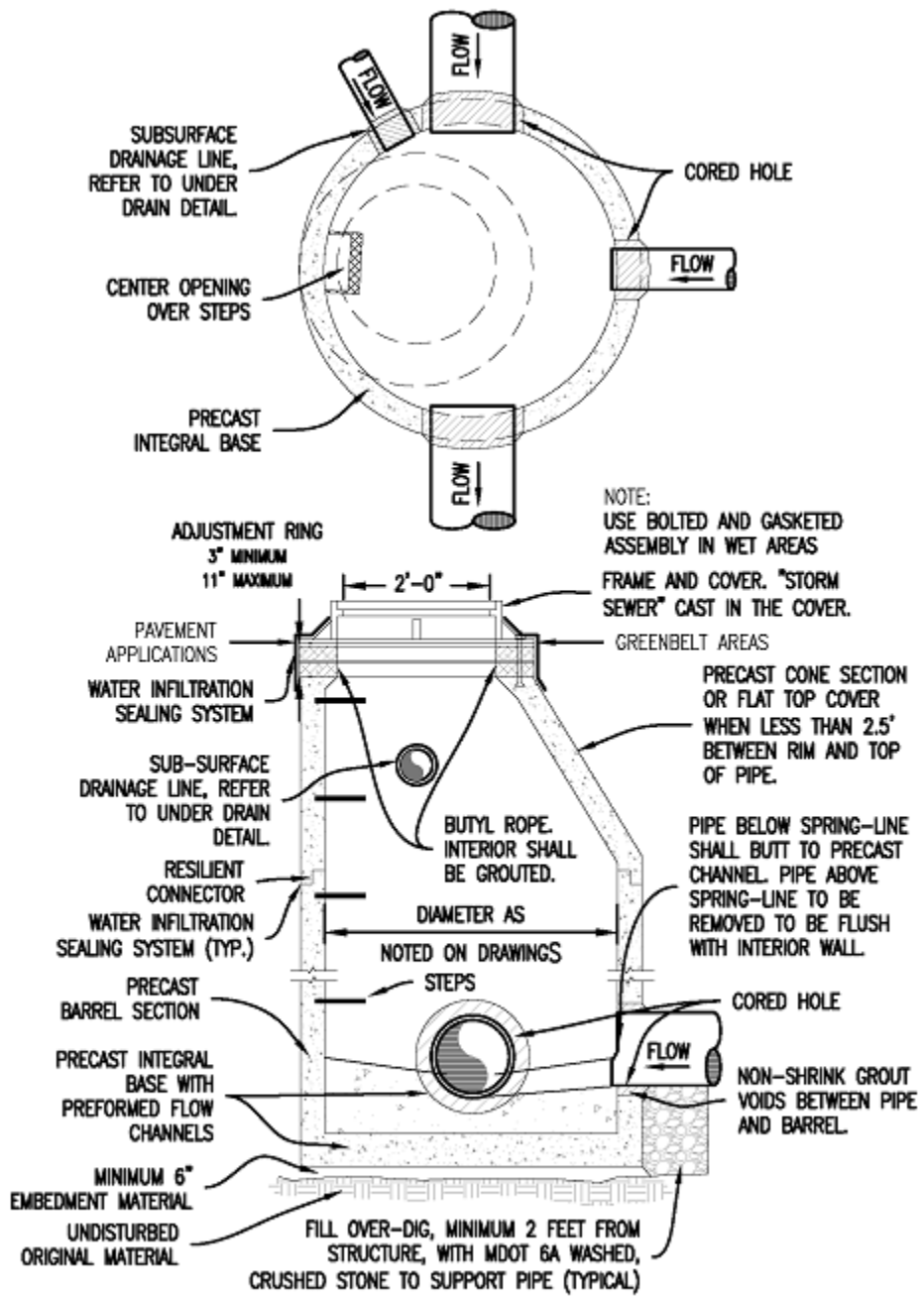

SECTION 48 80 31
STORM CATCH BASINS

PART 1 GENERAL

1.01 RELATED REQUIREMENTS

- A. Section 31 23 16.13 - Trenching: Embedment material.
- B. Section 33 05 13 - Manholes and Structures: Catch basin requirements.
- C. Section 34 01 00 - Street and other Hard Surface Improvements: Casting adjustments.

SEE NEXT PAGE(S) FOR DETAIL

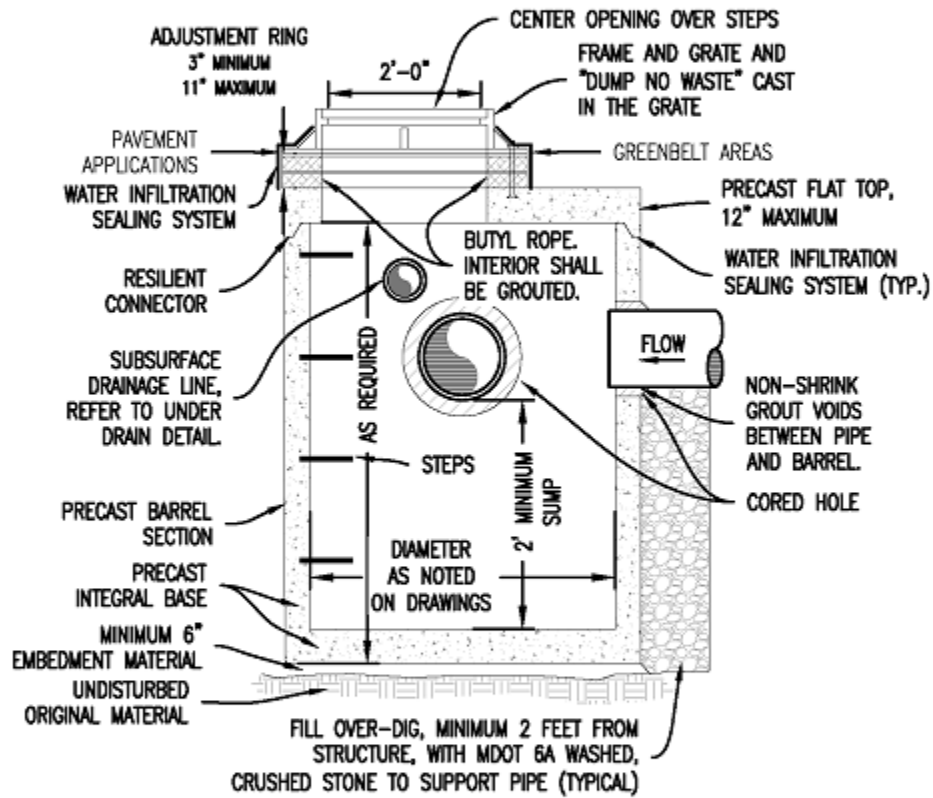

SECTION 48 80 32
CURB UNDERDRAIN

PART 1 GENERAL

1.01 RELATED REQUIREMENTS

- A. Section 33 05 13 - Manholes and Structures: Connections to manholes.
- B. Section 33 42 11 - Storm Sewer Piping: Underdrain pipe materials.

SEE NEXT PAGE(S) FOR DETAIL

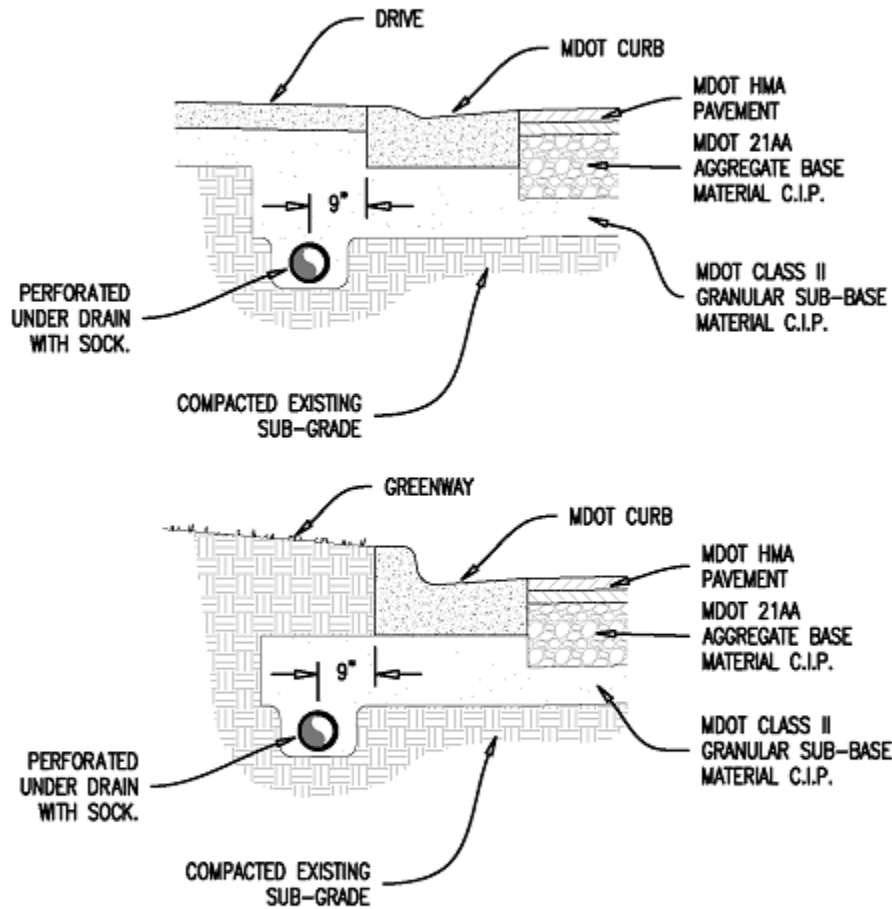

SECTION 48 80 33
PARKING UNDERDRAIN

PART 1 GENERAL

1.01 RELATED REQUIREMENTS

- A. Section 33 05 13 - Manholes and Structures: Connections to manholes.
- B. Section 33 42 11 - Storm Sewer Piping: Underdrain pipe materials.

SEE NEXT PAGE(S) FOR DETAIL

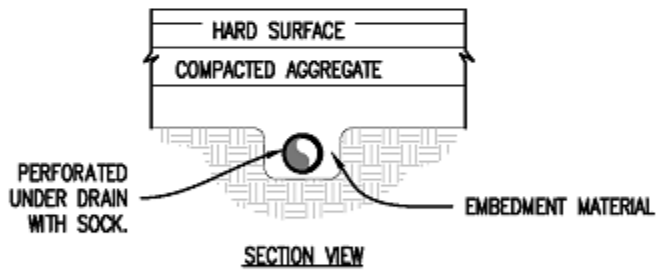
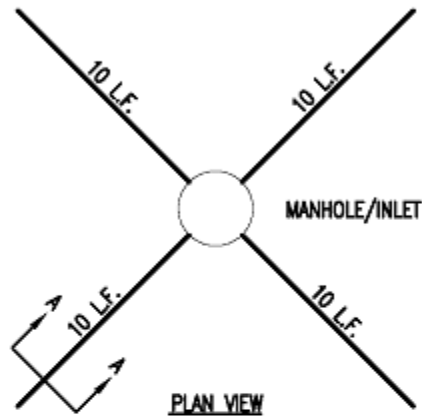

TAP STRUCTURES IN PARKING AREA AS SHOWN.
ADJUST TUBING AS REQUIRED TO AVOID SEWER LINES.

SECTION 48 80 34
CONCRETE CATCH BASIN COLLAR

PART 1 GENERAL

1.01 RELATED REQUIREMENTS

- A. Section 34 01 00 - Street and other Hard Surface Improvements: Concrete requirements.

SEE NEXT PAGE(S) FOR DETAIL

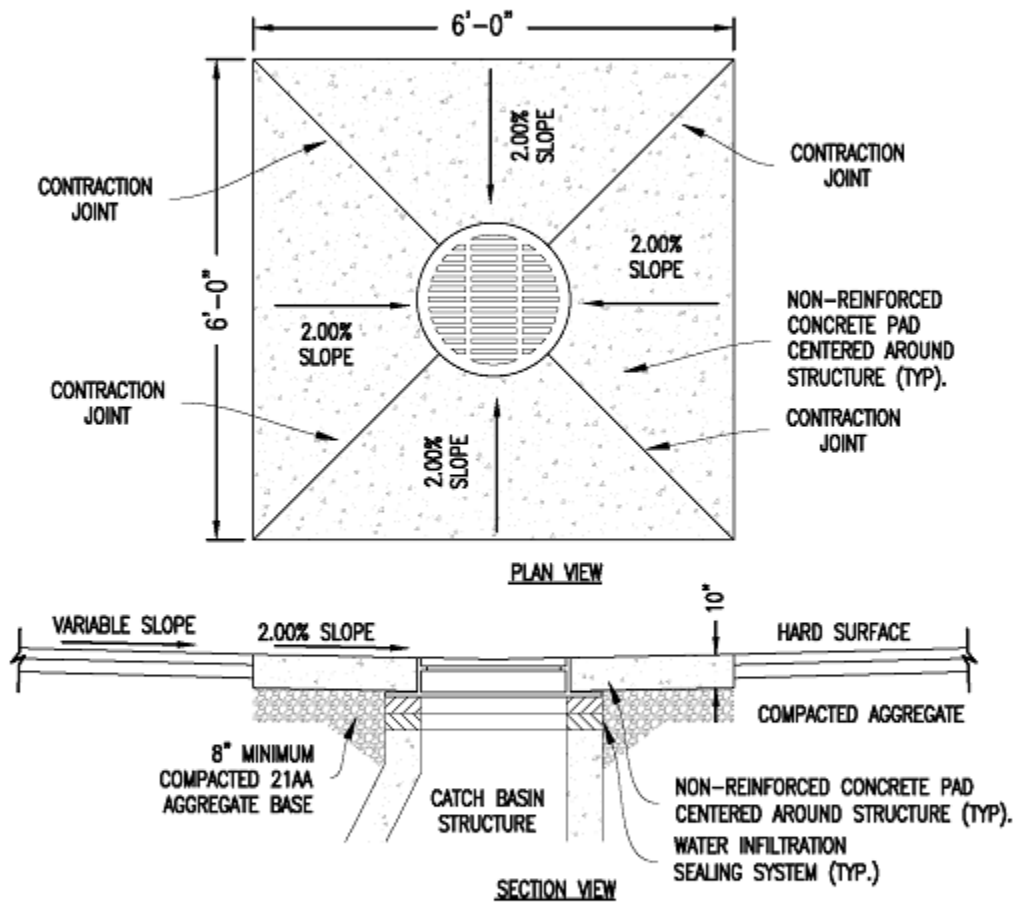

SECTION 48 80 35
DRIVEWAY CULVERTS

PART 1 GENERAL

1.01 RELATED REQUIREMENTS

- A. Section 33 09 01 - Installation and Acceptance Testing of Pipe and Accessories: Driveway culvert installation requirements.
- B. Section 33 42 11 - Storm Sewer Piping: Driveway culvert materials.
- C.

SEE NEXT PAGE(S) FOR DETAIL

